



RCK-862 *plus*



USB



Graphic Display



Supervisory System



Hour meter



Alarms



Progressive Algorithm



Suction Control



Discharge Control



Dynamic Condensation



Preset System



Modbus Protocol

1. SUMMARY

1. SUMMARY.....	2
2. DESCRIPTION.....	4
3. APPLICATIONS.....	5
4. GLOSSARY.....	5
5. TECHNICAL SPECIFICATIONS.....	6
6. ELECTRICAL PRECAUTIONS.....	6
7. INSTALLING THE RCK-862 plus	7
8. DIMENSIONS.....	7
9. WIRING SCHEMACTICS.....	8
10. NAVIGATION KEYS.....	9
11. NAVIGATION TUTORIAL.....	10
12. SUMMARY SCREENS.....	11
12.1 GROUP(S) SUMMARY SCREENS.....	11
12.2 SUCTION SUMMARY SCREENS.....	12
12.3 DISCHARGE SUMMARY SCREENS.....	14
12.4 CONTINUATION OF SUMMARY SCREENS.....	16
12.5 INDIVIDUAL PRESSURE.....	17
12.6 INDIVIDUAL THERMOSTATS.....	18
12.7 INPUTS AND OUTPUTS.....	19
12.8 AUXILIARY INPUT.....	20
12.9 ALARM OUTPUT.....	20
12.10 COMPRESSOR PROTECTION THERMOSTATS.....	21
12.11 PUMP CONTROL.....	21
12.12 ECONOMIZER.....	22
12.13 ANTIFREEZE.....	22
13. CONTROL MENU.....	23
14. COOLING GROUPS.....	24
14.1 SUCTION CONTROL.....	24
15. SUCTION CONTROLS.....	26
15.1 SUCTION CONTROL.....	26
15.2 MODULATION OF ON/OFF COMPRESSORS.....	26
15.3 MODULATION OF VARIABLE CAPACITY COMPRESSORS (VCC).....	27
15.3.1 VCC-ANALOG.....	27
15.3.2 VCC-DIGITAL.....	27
15.3.3 SCREW COMPRESSOR WITH SLIDE VALVE.....	28
15.4 CONTROL MODES.....	28
15.4.1 LINEAR MODE.....	28
15.4.1.1 LINEAR MODE LINKED ONLY WITH DIGITAL OUTPUTS-COMPRESSORS ON/OFF+UNLOADERS.....	28
15.4.1.2 LINEAR MODE LINKED WITH A VCC COMPRESSOR IN CONJUNCTION WITH ON/OFF COMPRESSORS.....	30
15.4.1.3 LINEAR MODE LINKED WITH A VCC-ANALOG COMPRESSOR.....	30
15.4.1.4 LINEAR MODE LINKED WITH A VCC-DIGITAL COMPRESSOR.....	31
15.4.2 ROTATION MODE.....	31
15.4.3 DEAD ZONE MODE.....	32
15.4.4 DEAD ZONE MODE WITH ROTATION.....	32
15.4.5 PROGRESSIVE ALGORITHM MODE.....	33
15.4.6 SATURATION TEMPERATURE CONTROL.....	34
15.4.7 CONTROL BY TEMPERATURE OF A SECONDARY FLUID.....	34
15.4.8 INTEGRAL ACTION.....	35
15.4.9 LOW PRESSURE DISCONNECTION.....	36
15.4.10 LUBRICATION CONTROL.....	37
15.4.11 CONTROL OF CAPACITY VARIATION RATE FOR VARIABLE COMPRESSORS.....	38
16. DISCHARGE CONTROLS.....	39
16.1 CONTROL MODES.....	39
16.2 TYPES OF DISCHARGE CONTROL.....	39
16.2.1 LINEAR MODE.....	39
16.2.1.1 LINEAR MODE LINKED ONLY WITH DIGITAL OUTPUTS-FANS ON/OFF.....	39

1. SUMMARY

16.2.1.2 INVERTER MODULATOR FAN.....	39
16.2.1.3 LINEAR MODE USING A FAN (INVERTER)IN CONJUNCTION WITH FANS LINKED WITH DIGITAL OUTPUTS.....	40
16.2.2 ROTATION.....	40
16.2.3 DEAD ZONE.....	40
16.2.4 DEAD ZONE+ROTATION.....	40
16.2.5 INTEGRAL ACTION.....	41
17. AUXILIARY FUNCTIONS.....	42
17.1 PUMP DOWN.....	42
17.2 AUTOMATIC SHUTDOWN COMMANDED BY RCK-862_{plus}	43
17.3 AUTOMATIC SHUTDOWN COMMANDED BY THERMOSTATS.....	45
17.4 PUMP CONTROL.....	47
17.5 DEFROSTING FOR SUCTION LINES.....	48
17.5.1 DEFROSTING BY TIME.....	48
17.5.2 DEFROSTING BY SCHEDULE.....	48
17.6 COMPRESSOR PROTECTION THERMOSTATS.....	49
17.7 ADIABATIC CONDENSATION.....	49
17.7.1 TEMPERATURE CONTROL.....	49
17.7.1.1 TEMPERATURE CONTROLLING USING TWO SENSORS (DIFFERENTIAL TBS-TBU).....	50
17.7.1.2 TEMPERATURE CONTROLLING USING A SENSOR (TBS).....	50
17.7.1.3 TEMPERATURE CONTROLLING USING TWO SENSORS (TBS-TBU DIFFERENTIAL AND TEMPERATURE LIMIT).....	50
17.7.1.4 CYCLE TIMER MODE.....	50
17.8 DYNAMIC CONDENSATION.....	51
17.9 INDIVIDUAL PRESSOSTAT.....	51
17.10 INDIVIDUAL THERMOSTAT.....	52
17.11 CONTROL STATUS.....	52
17.12 ECONOMIZER.....	53
17.13 ANTIFREEZE.....	54
18. ALARMS.....	55
18.1 ALARM VIEW.....	55
18.2 AUTOMATICS RESETS.....	56
18.3 OUTPUT SIGNALING.....	56
18.4 ALARM TABLES.....	57
18.4.1 SYSTEM ALARMS.....	57
18.4.2 SUCTION ALARMS.....	57
18.4.3 DISCHARGE ALARM.....	60
18.4.4 INDIVIDUAL PRESSOSTAT ALARMS.....	62
18.4.5 INDIVIDUAL THERMOSTAT ALARMS.....	62
18.4.6 ROTATION OUTPUT ALARMS.....	62
18.4.7 COMMUNICATION ALARMS WITH EXPANSIONS.....	62
18.4.8 SENSOR FAILURE ALARMS.....	63
18.4.9 ANTIFREEZE ALARMS.....	64
19. MAIN MENU.....	65
19.1 FUNCTIONS SETTINGS.....	65
19.2 SYSTEM SETTINGS.....	66
19.3 COMMUNICATION SETTINGS.....	66
19.3.1 COMMUNICATION WITH SITRAD.....	67
19.3.2 MODBUS COMMUNICATION.....	67
19.4 EXPANSIONS.....	67
19.5 DATA MANAGEMENT.....	69
19.5.1 EXPORTING PRESET.....	69
19.5.2 IMPORTING PRESET.....	69
19.5.3 FIRMWARE UPDATE.....	69
19.6 RESTORING FACTORY DEFAULT SETTINGS.....	69
20 PARAMETER TABLE.....	70
21 IMPORTANT.....	102
22 WARRANTY TERM.....	102

2. DESCRIPTION

The **RCK-862 plus** is an expandable electronic controller from the Rackcontrol line for application in commercial and industrial refrigeration compression plants. It can control in low and medium temperature applications with up to three suction lines and three discharge lines. In addition to controlling and monitoring, it has two independent RS-485 communication ports that can be used for remote control via Sitrad software or other equipment via MODBUS protocol. For more information about the implemented commands and the registration table, contact Full Gauge Controls

The **RCK-862 plus** is capable of controlling pressure or temperature, through its 6 configurable inputs for sensors and 8 digital inputs for monitoring devices and external drivers. Its robust hardware also has eight control outputs for compressors or fans, two analog outputs for proportional control and six digital outputs (three relay outputs and three solid state type) for ON-OFF control of compressors, unloader valves and fans. Its three solid state relays can be used together with dedicated logic for controlling digital compressors of variable capacity. The **RCK-862 plus** is a control module that acts alone or together with expansion modules to increase the number of inputs and outputs in large systems.

The **RCK-862 plus** is capable of regulating compressors using pressure sensors to control the pressure or saturation temperature of the refrigerant, or use temperature sensors to directly control the temperature of secondary circuits such as glycol and water chiller.

The **RCK-862 plus** has advanced control logic to optimize thermal performance and reduce the energy consumption of the cooling system. The proportional-integral control seeks to minimize the variation in temperature/pressure of the suction line. The progressive algorithm, which seeks to match the cold demand required by the plant with the power of the set of compressors, seeking to reduce the number of compressor actuations and shutdowns. The dynamic condensation control logic, where the temperature of the external environment is monitored to reduce the condensation setpoint, consequently reducing the compression ratio of the system and its energy consumption.

The **RCK-862 plus** has a user-friendly interface through a high-brightness OLED display, six interaction keys and a control menu that provides the commands most used by the compression center. Simple to operate and configure, the **RCK-862 plus** is equipped with an internal buzzer (audible warning), key and screens for monitoring alarms that simplify the process of monitoring and identifying faults in the refrigeration system. There is also a real-time clock (RTC) that allows you to automate commands and record the times of alarms. The USB connection can be used to upload and download configuration parameters, as well as to update the firmware.

3. APPLICATIONS

- Low and medium power industrial refrigeration
- Rack type refrigeration equipment (compressors in parallel)
- Compression centers for supermarkets, logistic storage centers or air conditioning systems
- Cold storage facilities
- Condensing units
- Plug-ins
- Chillers

4. GLOSSARY

Group: It is a set of suction or discharge lines that are linked (same refrigerator circuit).

Control line: A circuit section with the same pressure or temperature control, for example: suction or discharge.

Unloader: Capacity regulating valve on compressors.

Hysteresis: Range of variation of the control parameter, also known as Control differential.

Setpoint: Desirable value of the control parameter (pressure or temperature).

Pressostat: Pressure control based on a setpoint and a hysteresis.

Thermostat: Temperature control based on a setpoint and a hysteresis.

Superheating: Temperature difference above a refrigerant's boiling point for a given pressure.

Subcooling: Temperature difference below the dew point of a refrigerant for a given pressure.

Compression: Pressure control where the hysteresis interval is below the setpoint.

Decompression: Pressure control where the hysteresis interval is above the setpoint.

SSR: Solid State Relay. Electronic device for driving electric loads that allows a higher frequency of switching than electro-mechanical relay. Used to drive alternating current (AC) charges only.

VCC: Variable Compressor Capacity Compressor. Name the compressor that allows modulation within a continuous range, usually between 10 and 100%.

VCC-Analog: Compressor whose capacity is modulated by means of an analog output from the controller (0-10V signal).

VCC-Digital: Compressor whose capacity is modulated through the actuation of digital outputs (SSRs) to control unloaders valves.

Primary fluid: Refrigerant fluid circulating in the main refrigeration circuit. E.g., R404A.

Secondary fluid: Fluid circulating in a circuit different from the main refrigeration circuit. E.g., Glycol.

Saturation temperature: Value resulting from the pressure sensor reading converted to temperature.



Have this manual at the palm of your hand through the FG Finder application

5. TECHNICAL SPECIFICATIONS

Power Supply	24Vac 50/60Hz or 24Vdc \pm 10%
Maximum consumption	500mA ac/dc
Controller operating temperature	-20 to 60°C / -4 to 140°F
Operating Humidity Range	10 to 90% UR (without condensation)
Type action	Type 1.B
Pollution degree	II
Software class	Class A
Control pressure	0.1 psi / 0.1 bar
Pressure resolution range	-14,7 to 3191psi / -1,0 to 220,0 bar
Control temperature range	-50 to 200°C / -58 to 392°F
Temperature resolution	0.1°C / 0.1 °F across all range
Analog inputs	S1 to S6: Configurable between pressure sensor (4 to 20mA / SB69) or temperature sensor (SB19, SB41, SB59, Sb70);
Voltage output for pressure sensors	Voltage output +12V: 12Vdc, Idcmax= 120mA;
Digital inputs	I1 to I5: dry contact type digital inputs. Hi1 to Hi3: Isolated digital inputs, with maximum voltage equal to the supply voltage (24V)
Analog outputs	A1 = 0-10Vdc (max. 10mA) A2
Digital outputs	O1, O5 and O6: relay output (SPST) NO, 5(3)A/250Vac; O2, O3, and O4: output with solid state relay (SSR) 1A/24 - 240Vac
USB Interface	Compatible with the USB 2.0 Full-Speed Module (USBFS) standard; Data format for FAT32 pendrive / Maximum size of 32GB pendrive
RS-485 communication interface	RS485-1: Not insulated RS485-2: Insulated EXP: Communication with expansion modules
Product dimensions (WxHxD)	70,0 x 135,7 x 61,7 mm (2,76" x 5,34" x 2,43")

6. ELECTRICAL PRECAUTIONS

 **BEFORE INSTALLING THE CONTROLLER, WE RECOMMEND THAT THE FULL READING OF THE INSTRUCTION MANUAL BE DONE, IN ORDER TO AVOID POSSIBLE DAMAGE TO THE PRODUCT.**

 **PRECAUTION WHEN INSTALLING THE PRODUCT:**

- Before performing any procedure on this instrument, disconnect it from the power supply;
- Certify that the instrument has adequate ventilation, avoiding installation on panels that contain devices that may cause it to operate outside the specified temperature limits;
- Install the product away from sources that may generate electromagnetic disturbances, such as: motors, contactors, relays, solenoid valves, etc.

 **AUTHORIZED SERVICE:**

- Installation or maintenance of the product must be performed only by qualified professionals.

 **ACCESSORIES:**

- Use only Full Gauge Controls original accessories;
- In case of doubt, contact technical support.

BEING IN CONSTANT DEVELOPMENT, FULL GAUGE CONTROLS RESERVES THE RIGHT TO CHANGE ANY INFORMATION IN THE MANUAL AT ANY TIME, WITHOUT PRIOR NOTICE.

7. INSTALLING THE RCK-862 *plus*

7.1 Fixing by DIN rail.

To fix the interface on the DIN rail, position the interface fit the top part in place as shown.

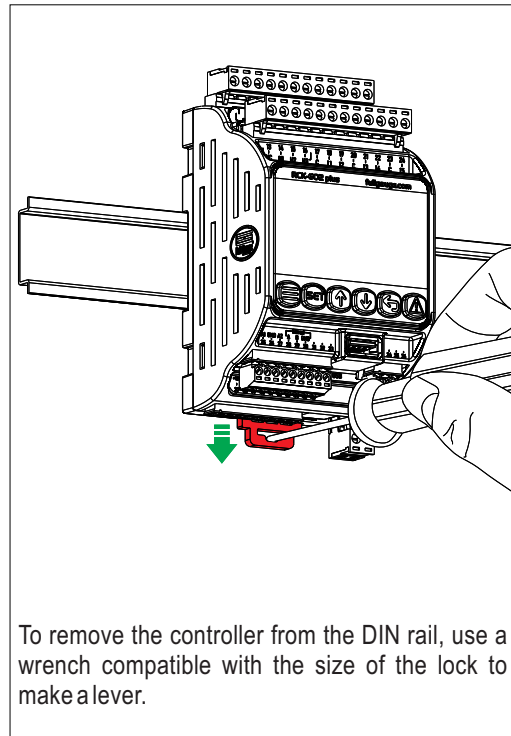
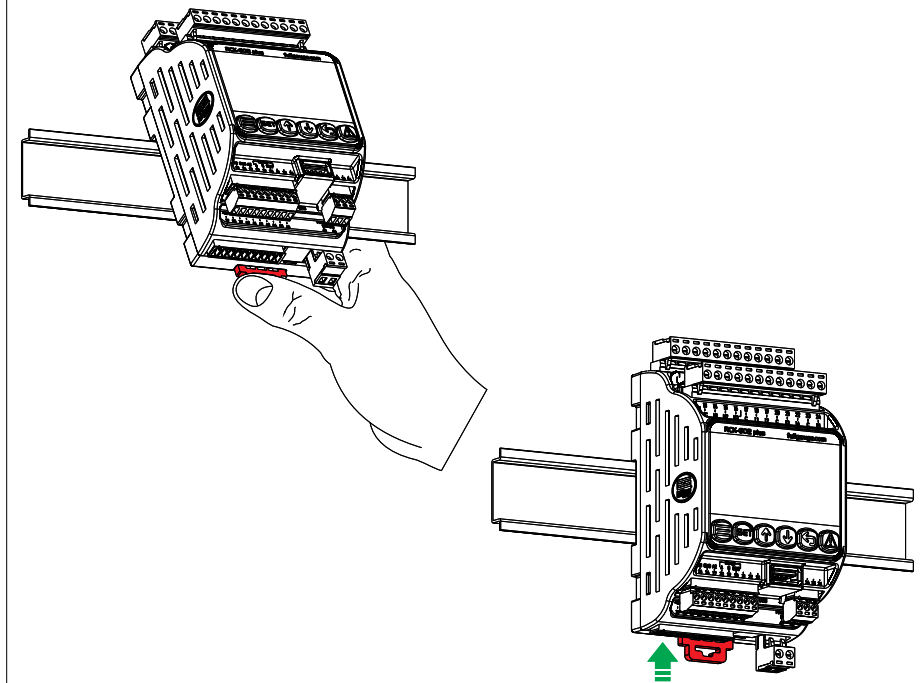

To remove the controller from the DIN rail, use a wrench compatible with the size of the lock to make a lever.

8. DIMENSIONS

For a better fixation of the **RCK-862 *plus*** observe the product dimensions.

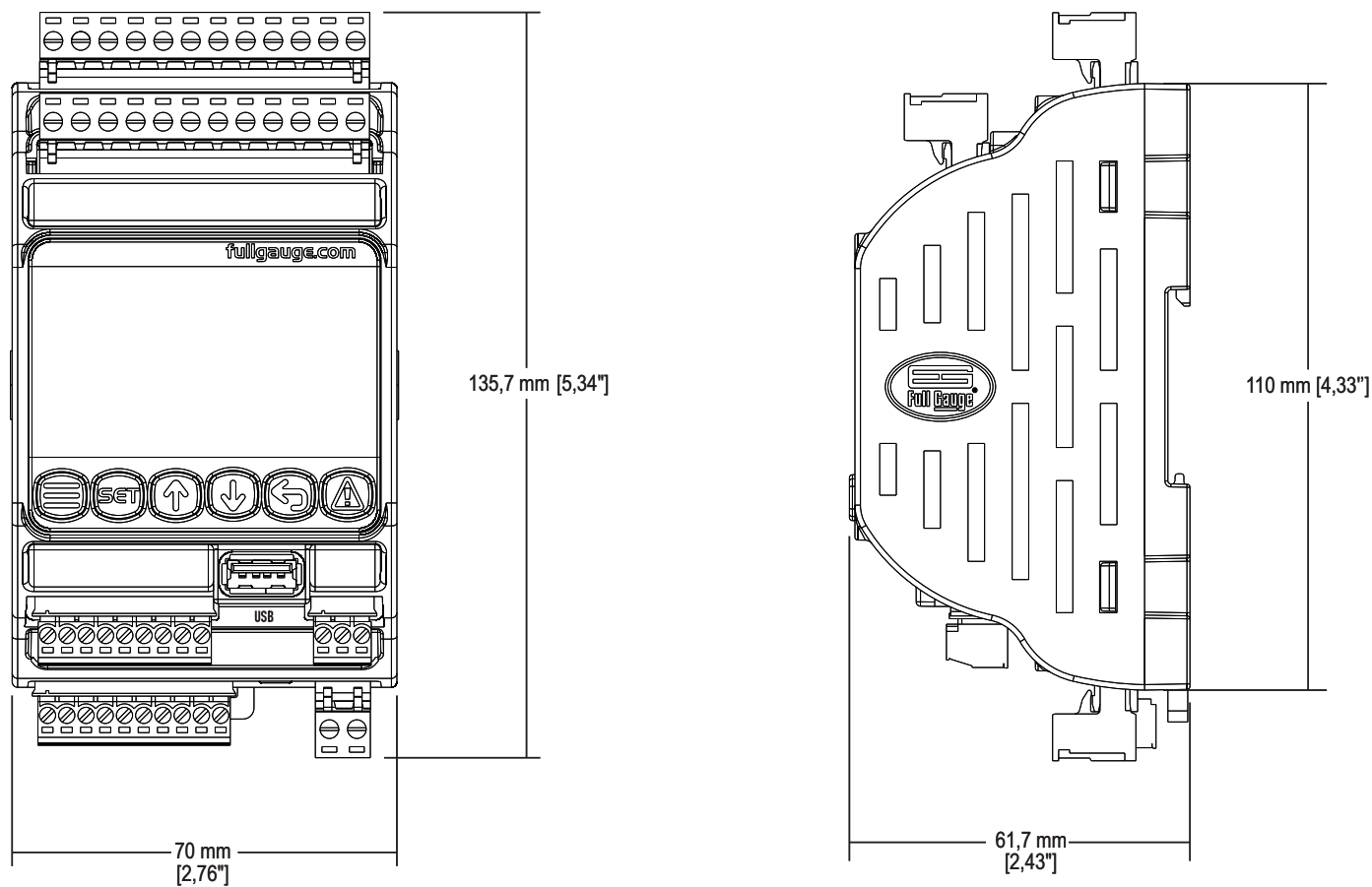

9. WIRING SCHEMATICS

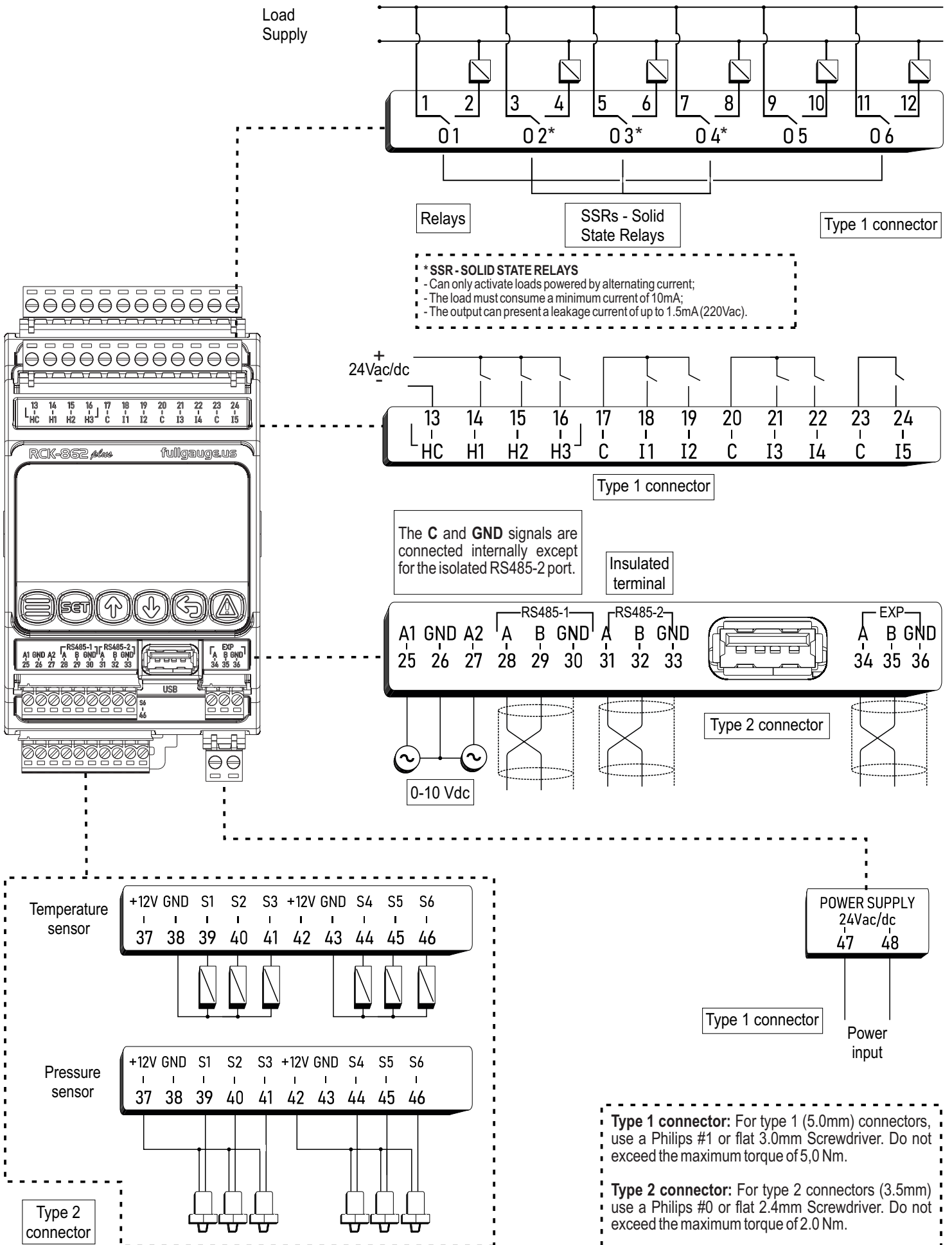

Note: You can install up to 6 sensors configurable between temperature and pressure depending on the installation.

10. NAVIGATION KEYS

To toggle between screens, edit parameters, view advanced functions and other features, the **RCK-862_{plus}** has 6 navigation keys:

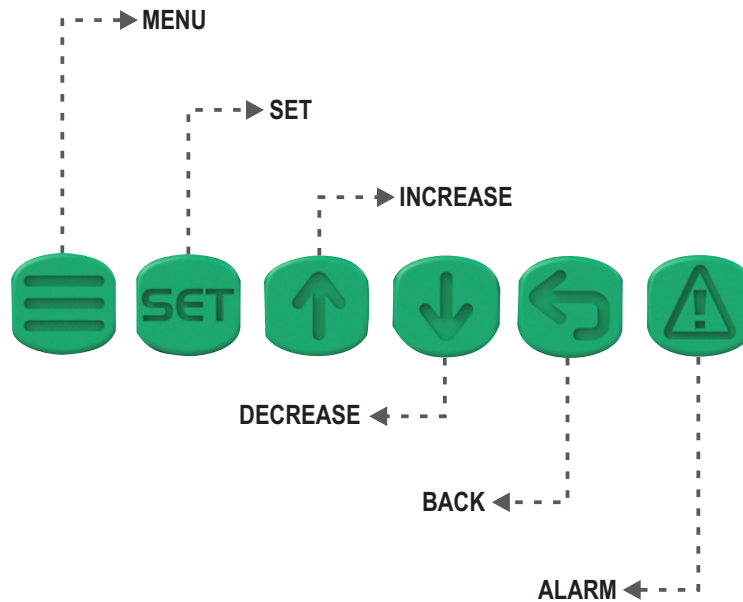

MENU key: Access the Main Menu and the Control Menu.

Control Menu: Press the MENU key.

Main Menu: Press and hold the MENU key for 2 seconds.

SET key: Confirms and edits the parameters and values.

INCREASE key: Increases values and navigates “up” up through menu options.

DECREASE key: Decreases values and navigates “down” down through menu options.

BACK key: Returns to the previous screen without saving parameter changes.

ALARM key: Access the display of active alarms, alarm history and alarms on reset.

Press the alarm key to switch between the Active Alarms, Alarm History and Reset Alarms screens. To clear the alarm history or view the alarm history press and hold the alarm button for 5 seconds.

Note: requires Administrator access level.



Note: To change the controller's language, press the **MENU**  and **DECREASE**  buttons together for 5 seconds.

11.NAVIGATION TUTORIAL

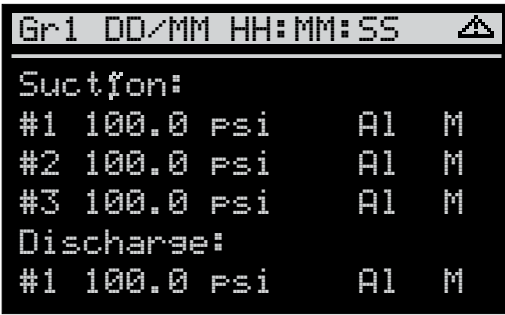

The first summary screen is the **GROUP 1**. You can find information about the controlled system.



By using the **INCREASE** and **DECREASE** keys it is possible to navigate through the other summary screens.

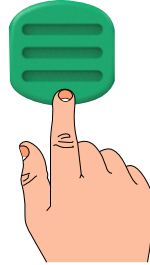
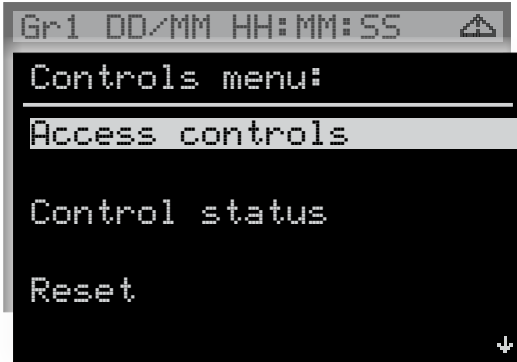

A short press on the **MENU** key accesses the Control Menu. This menu presents the main commands and settings for system operation.

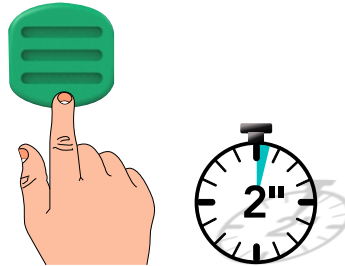

Press the **MENU** key for 2 seconds to access the Main Menu. The Main Menu groups the cooling system settings to be controlled.

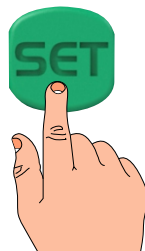
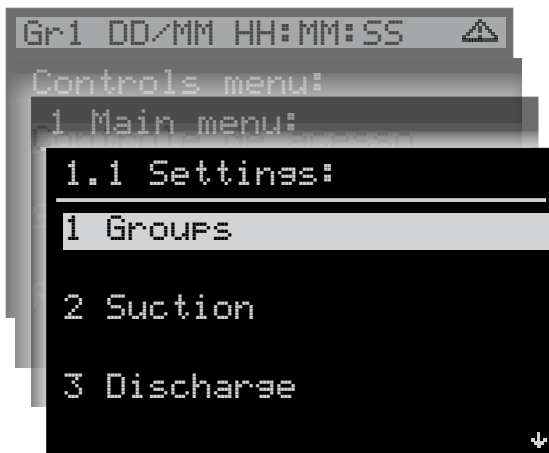

The **SET** key is used to access the selected settings options.

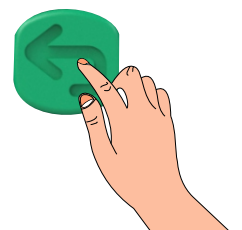

The **BACK** key is used to return to the configuration menus, with a short touch it is possible to return to the previous level.

12.SUMMARY SCREEN

12.1. Group summary screen:

Displays the basic status of the lines (Suction and/or Discharge) that make up the group, when configured to display it. By default, the **RCK-862 plus** is configured with Suction 01 and Discharge 01 in Group 01. If the Group is not configured, access the **Main Menu** → **Function Settings** → **Groups**. For more information see section 18. **Main Menu** → **Function 1 . 1 . 1**

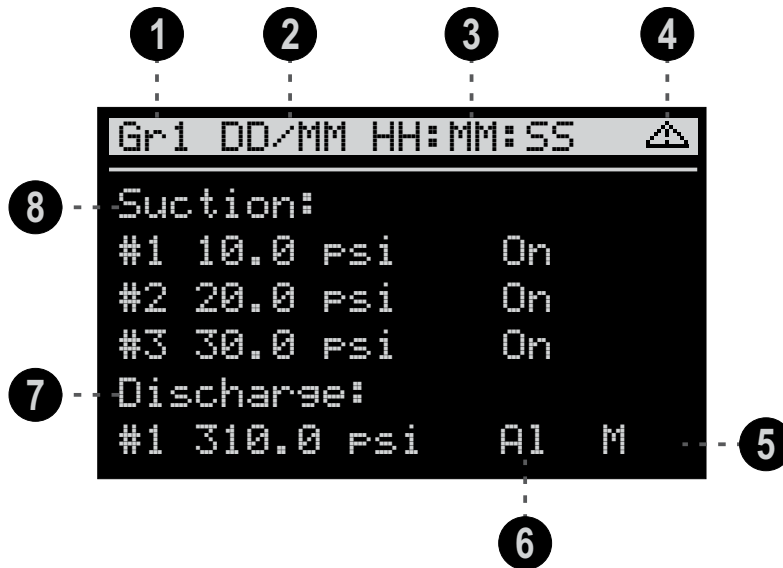

1 – Group identification on display:

Gr1: Group 1;
Gr2: Group 2;
Gr3: Group 3.

2 – DD/MM : Indicates the current date.

3 – HH:MM:SS Reports current time.

4 –  : Indication of active alarm.

5 – Auxiliary indications:

M: At least 1 compressor or fan in maintenance;
Eco: When the economic setpoint is active;
Pd: In the process of Pump Down;
FLT: Active floating condensation;
ADI: Active adiabatic condensation.

Note: When more than one auxiliary function is active on the same line (Suction or Discharge), the icons will alternate on the display.

6 – Indication of control status:

Wait: Waiting for control to start;
On: Turn On;
Off: Turn Off;
Lock: Locked;
A1: In alarm or automatic reset;
A1 (Blinking): Waiting for manual reset;
Def: Defrost.

7 – Displays the discharge pressure switch configured for the group. If there is no discharge enable, an empty line will display.

Note: The group number determines the number of the discharge line that will be used. For example, discharge 03 will only be used in group 03.

8 – Displays the number of suction pressure switches configured for the group. If there is no suction enabled, an empty line will display.

12.SUMMARY SCREEN

12.2. Suction summary screen:

On this screen it is possible to view the basic suction status.

To configure the Suction lines, access the **Main Menu** → **Function settings** → **Suction**. For more information see section 18. **Main Menu** → **Function 1.1.2**

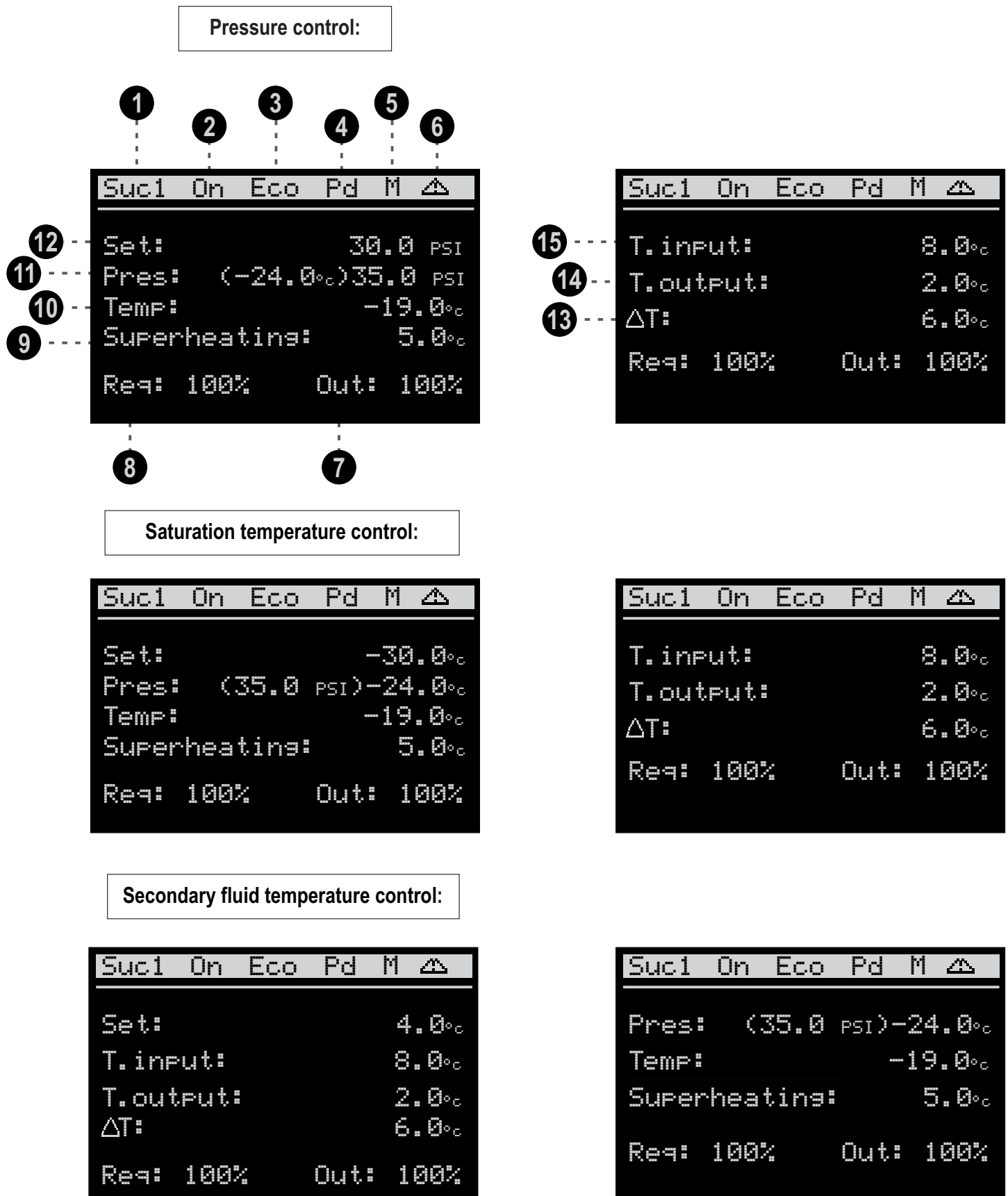

12.SUMMARY SCREEN

- 1 – Identification of the suction line on display:
Suc1 : Suction 1;
Suc2 : Suction 2;
Suc3 : Suction 3.
- 2 – Control status indication:
Wait : Waitin for control to start;
On : Turn On;
Off : Turn Off;
Lock : Locked;
Al : In alarm or automatic reset;
Al (Blinking) : Waiting for manual reset;
Cf@ : Line with no configuration parameter.
Dis : Disabled via command or digital input.
- 3 – Eco : Active economic setpoint.
- 4 – Pd : In the process of Pumping Down.
- 5 – M : At least 1 compressor in maintenance.
- 6 –  : Indication of active alarm.
- 7 – Out : Percentage of power referring to the active outputs by RCK-862 *plus*.
- 8 – Req : Percentage of power required by the system for the operating interval.
- 9 – Superheating : Calculation of overheating based on pressure measurement, temperature, and type of parameterized refrigerant. If the controller identifies that the suction is working in the transcritical part of the refrigerant, the message PC will be displayed.
- 10 – Temp : It is the value of the suction evaporation temperature sensor.
- 11 – Pres : It is the pressure value read by the suction transducer.
- 12 – Set : Display the current value of the setpoint, it can be the economic pressure setpoint or the main pressure setpoint. (Depending on which is active).
- 13 – ΔT : It is the difference between the input and output temperatures of the secondary circuit.
- 14 – T. output : It is the value of the fluid outlet temperature of the secondary circuit.
- 15 – T. input : It is the value of the inlet temperature of the fluid in the secondary circuit.

12.SUMMARY SCREEN

12.3. Discharge summary screen:

Displays the basic status of the enabled Discharge line.

To configure the Discharge lines, access the **Main Menu** → **Function Configuration** → **Discharge**. For more information see section 18. Main Menu → Function 1.1.3

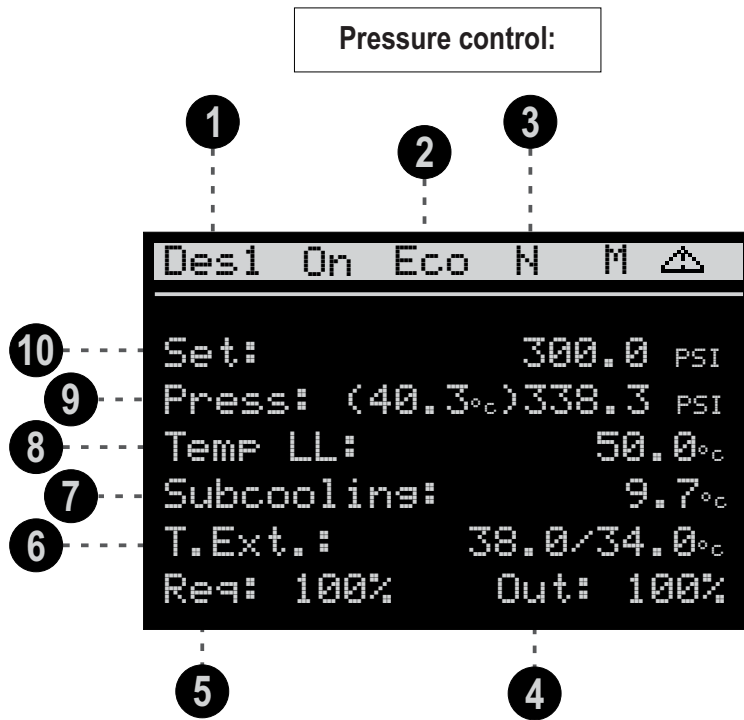

Saturation temperature control:

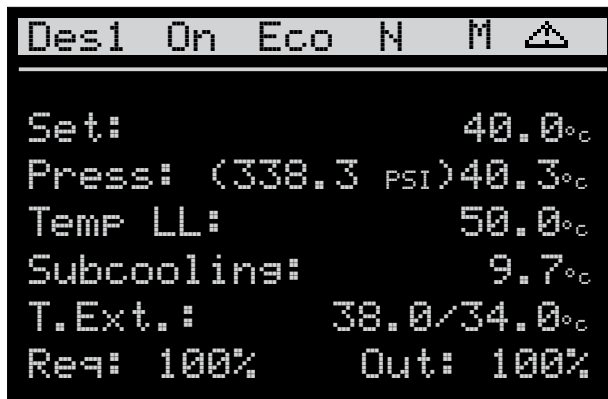

Liquid line temperature control

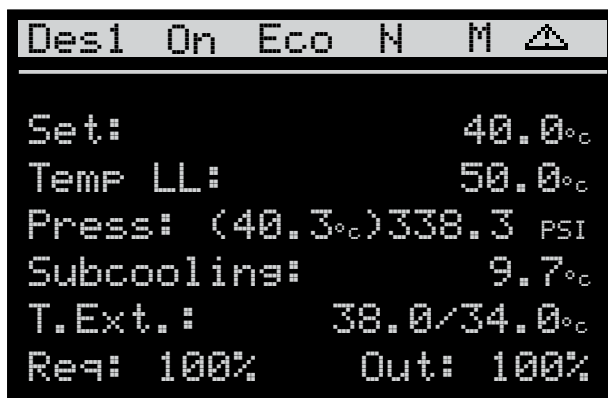

12.SUMMARY SCREEN

- ① – Identification of the discharge line on display:
 Dis1: Discharge 1;
 Dis2: Discharge 2;
 Dis3: Discharge 3.
- ② – Eco: Active economic setpoint.
- ③ – N: In night mode.
- ④ – Out: Percentage of power referring to the active outputs by the **RCK-862 plus**.
- ⑤ – Req: Percentage of power required by the system for the operating range.
- ⑥ – T. Ext.: Represents the value of the external temperature sensor(s).
- ⑦ – Subcooling: Calculation of subcooling based pressure measurement, temperature, and type of refrigerant settings. If the controller identifies the suction that is operating in the transcritical part of the refrigerant, the message PC will be displayed.
- ⑧ – Temp LL: It is the temperature value of the liquid line, used for calculate subcooling.
- ⑨ – Pres: It is pressure value read by the discharge transducer.
- ⑩ – Set: Displays the active pressure or temperature setpoint value. It can be the main or economic setpoint or resulting from the calculation of the dynamic condensation logic.

Discharge control

①	Des1 On Eco N M
②	T. din. cond.: 25.0°C
③	TBS: 28.0°C
④	TBU: 25.0°C
⑤	Adb output.: Off

- ① – Identification of the discharge line on display:
 Dis1: Discharge 1;
 Dis2: Discharge 2;
 Dis3: Discharge 3.
- ② – T. din. cond.: Reference external temperature for dynamic condensation.
- ③ – TBS: Dry bulb temperature.
- ④ – TBU: Humid bulb temperature.
- ⑤ – Adb output: Status of the adiabatic condensation output.

12.SUMMARY SCREEN

12.4. Continuation of summary screens:

For each suction and discharge has a summary screen where you can see how many outputs are connected and their respective status. After the equal sign, you can see the percentage number of the control outputs connected with each compressor and fan that are on. It can even monitor the capacity control status (unloaders valves and inverter output).

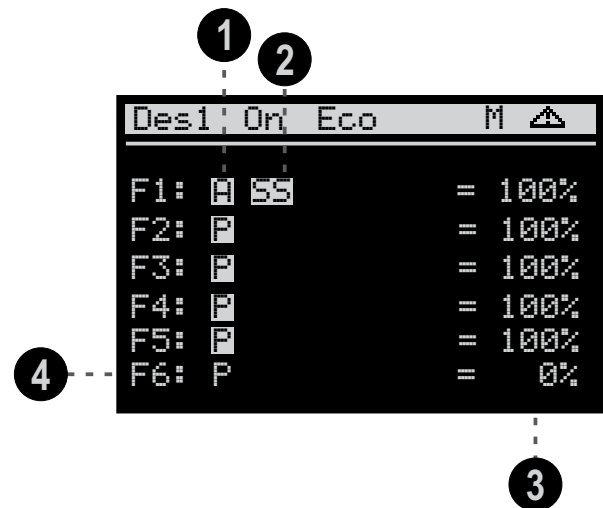
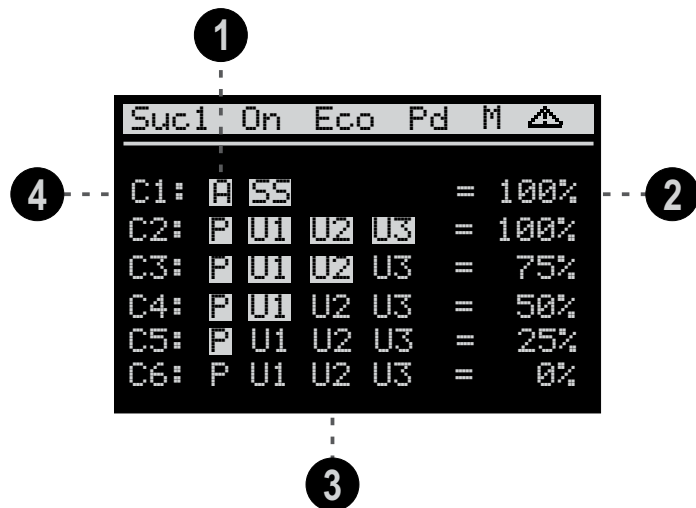

- 1 – The letter P represents the activation of the compressor's main output. When digital output P is indicated with a white background, it means the relay is activated.
The letter A symbolizes the analog (proportional) output-compressor configured as an inverter. For values above 0% the letter A is displayed with a white background.
- 2 – This value represents the percentage of the power supplied by each compressor
- 3 – The auxiliary outputs (unloaders) are represented by the letter U.
The Start-Stop output of the compressor with VCC-Analog modulation will be represented by the letters SS
- 4 – Lists all compressors enabled on the suction pressure switch.



- 1 – The letter P represents the activation of the fan output. When digital output P is indicated with a white background, it means that its relay is activated.
For fans with inverter modulation (only the F1 fan can be configured) the letter A symbolizes the value of the analog output. For values above 0% the letter A will be shown with a white background.
- 2 – For fans with modulation, the SS symbol represents the status of the Start-Stop output.
When this output is activated, it is represented with a white background.
- 3 – This value represents the percentage of the power supplied by each fan.
- 4 – It lists all enabled fans of the discharge line, there could be total of six.

White background	
Actuated output	□
Black background	■
Output configured but shutdown	■

12.SUMMARY SCREEN

12.5. Individual pressure switches:

The individual pressure switch screens are accessed from the Control Menu.

To toggle between the available pressure switches just navigate using the keys  and .

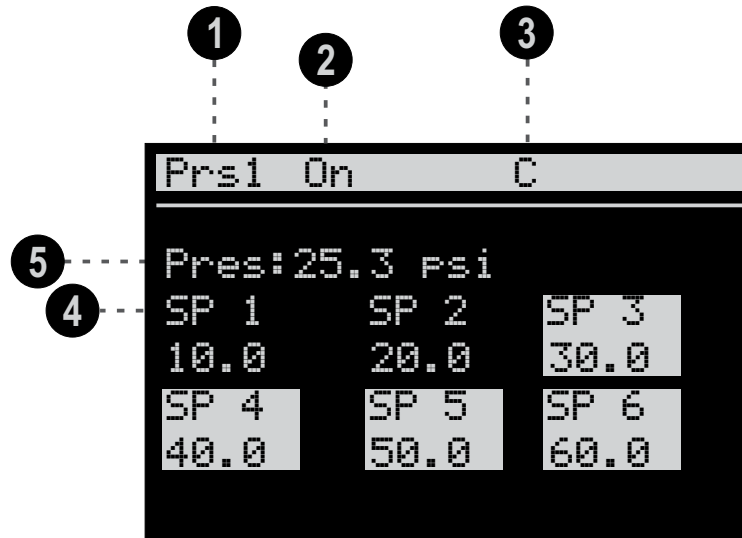

- ① – Pressure switch on display Prs1, Prs2 or Prs3.
- ② – On -turned on;
Off -turned off.
- ③ – Operation mode:
C: compression;
D: descompression.

- ④ – Displays the setpoint for each digital output of the individual pressure switch.
Sets presented with white background indicate that the respective output is active. In this example, output 1 and 2 are off and outputs 3, 4, 5 and 6 are on.
- ⑤ – Control pressure value.

White background

Actuated output



Black background

Output configured but is shut off.

12.SUMMARY SCREEN

12.6. Individual thermostats:

The individual thermostat screens are accessed from the Control Menu.

To toggle between the available pressure switches just navigate using the keys  and .

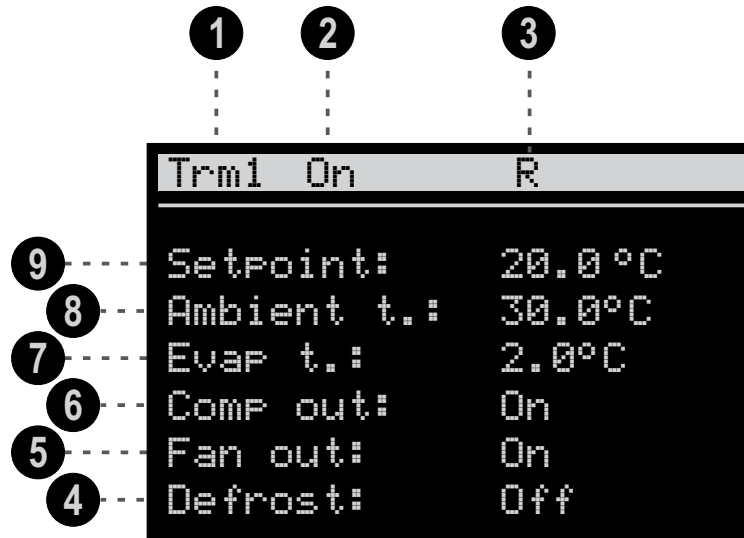

- 1** – Thermostat on display:
Trm1: Individual thermostat 1;
Trm2: Individual thermostat 2;
Trm3: Individual thermostat 3.
- 2** – On -turned on;
Off -turned off;
Pre -pre-defrost.
Des -defrost.
Drain -drainage.
Fan -fan delay.
Int -interlock.
Wait -initial delay.
Dis: Disabled via command or digital input.
- 3** – Operation mode:
A: heating;
R: refrigeration.
- 4** – Defrost output status.
- 5** –Ventilation output status
- 6** – Compressor output status
- 7** – Evaporator temperature /Temperature sensor for defrost end.
- 8** – Room temperature
- 9** – Temperature setpoint.

12.SUMMARY SCREEN

12.7. Inputs and outputs:

The input and output menu allows you to view the status of all inputs and outputs of the **RCK-862_{plus}** and its configured expansion modules, as well as to check their function.

①

Outputs - Base			
01:	Off	A1:	10.0V
02:	Off	A2:	5.0V
03:	Off		
04:	Off		
05:	Off		
06:	Off		

②

①

Inputs - Base			
HI1:	Off	S1:	93.6 Psi
HI2:	Off	S2:	32.0 Psi
HI3:	Off	S3:	379.7 Psi
I1:	On	S4:	7.0 °C
I2:	Off	S5:	Fail
I3:	Off	S6:	15.4°C

② ②

① — Indicates which equipment is being viewed.

② — Indicates the status or value of the output.

① — Indicates which equipment and item are being viewed.

② — Indicates the status or value of the input.

To see which function is assigned to a particular output or input, press **SET** navigate to the desired item using the keys **↑** and **↓** press **SET** again.

①

Outputs - Base			
01:	Off	A1:	10.0V
02:	Off	A2:	5.0V
03:	Off		
04:	Off		
05:	Off		
06:	Off		

②

Output - Base 02	
③	Suction 1
	Compressor 1
	Output main



① — Indicates the selected item.

② — Indicates the connected pressure switch.

③ — Indicates the function of the selected item.

12.SUMMARY SCREEN

12.8. Auxiliary inputs:

The auxiliary inputs menu allows viewing the current status of all auxiliary digital inputs of the **RCK-862_{plus}**, as well as checking their functions. To check which function is assigned to a given input, navigate to the desired item using the  and  keys and press .

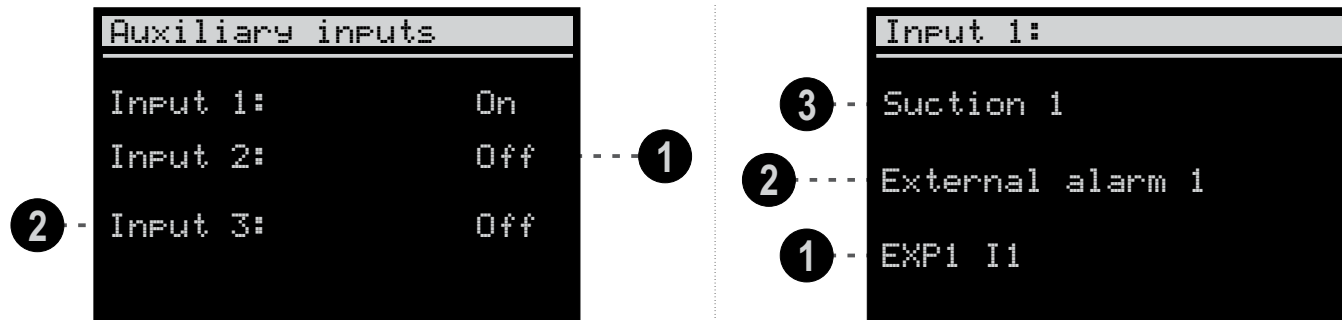

1 — Indicates the status of the digital input.

2 — Indicates the auxiliary input number.



1 — Address input.

2 — Input function.

3 — Link use.

12.9. Alarm outputs:

The alarm outputs menu allows you to view the current state of the alarm outputs of the **RCK-862_{plus}**, as well as check their function.

To visualize which function is assigned to a given output, navigate to the desired item using the  and  keys and press .

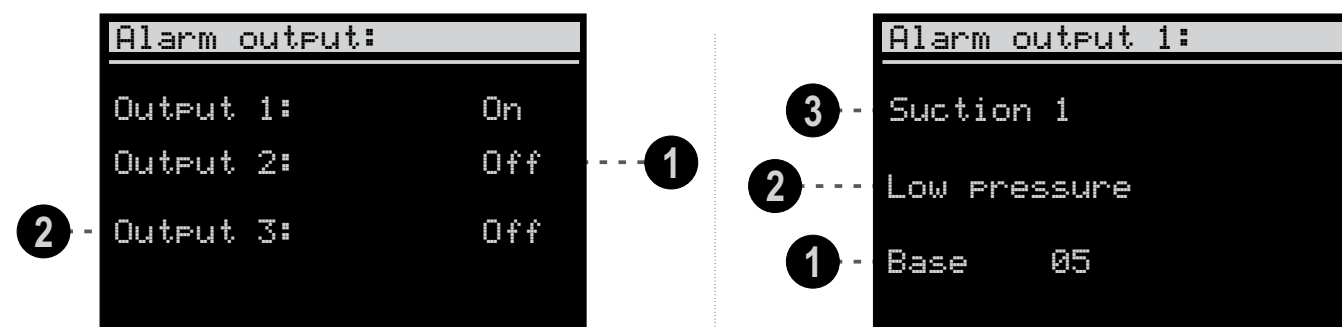

1 — Indicates the status of the digital output.

2 — Indicates the alarm output number.

1 — Address input.



2 — Input function.

3 — Link use.

12.SUMMARY SCREEN

12.10. Compressor protection thermostats:

Thermostat information is accessed from the Control Menu.

To toggle between the available compressors just navigate using the keys  and .

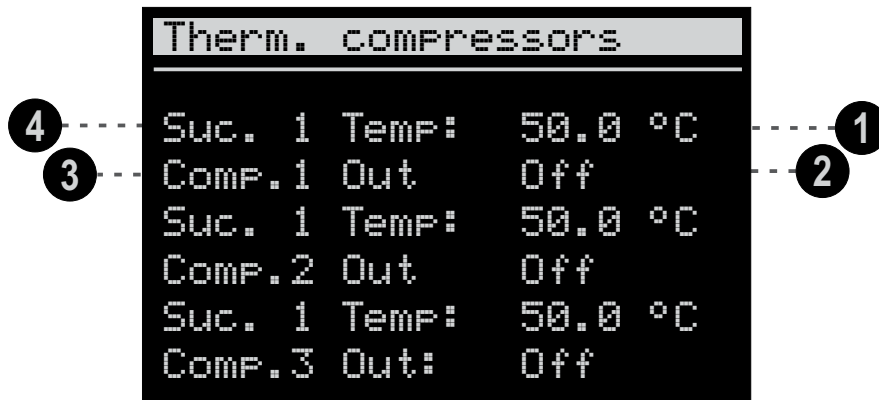

1 — Compressor temperature.

3 — Compressor reference.

2 — Protection output status.

4 — Suction line.

12.11. Pump control:

It allows viewing the status of the outputs of the sets of rotation outputs.

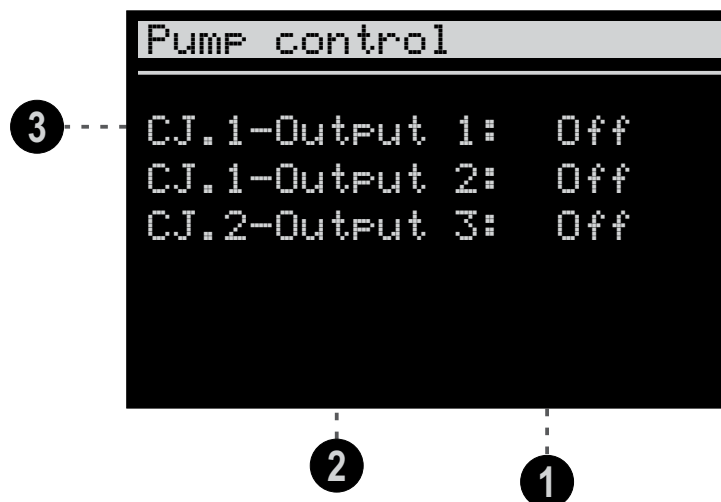

1 — Indicates output status
On: Output on
Off: Output off
AL: Output in alarm

3 — Indicates the set to which the output belongs.

2 — Indicates the output index.

12.SUMMARY SCREEN

12.12. Economizer:

Allows viewing of Economizer information.

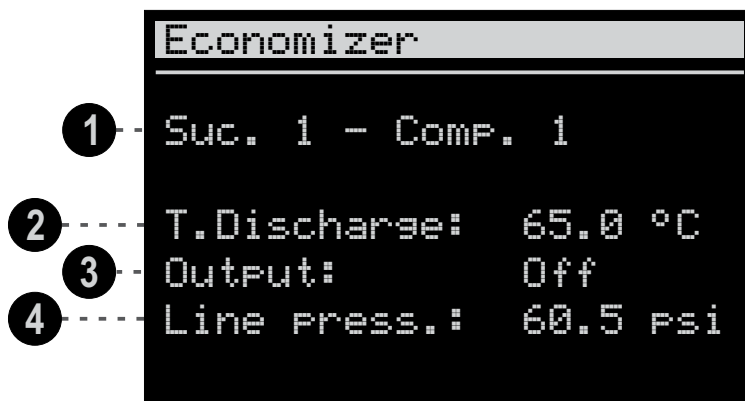

1 — Suction and compressor reference.

3 — Output status.

2 — Compressor discharge temperature.

4 — Economizer line pressure.

12.13. Antifreeze:

Allows viewing of the Antifreeze information.

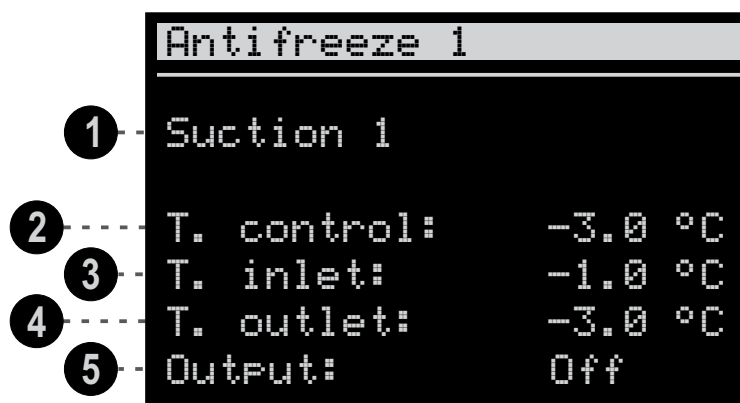

1 — Suction and compressor reference.

4 — Inlet temperature.

2 — Control temperature.

5 — Output status.

3 — Outlet temperature.

13. CONTROL MENU

The Control Menu is accessible by pressing the  key, has settings and commands for easy access to the operations of the **RCK-862_{plus}**.

Control menu:	
1	Access control
2	Control status
3	Suction Control
4	Thermostat Control
5	Resetting alarms
6	Setpoint Adjustment
7	Economic setpoint
8	Pump Down
9	Manual defrost
10	Adiabatic Cond.
11	Dynamic condensation
12	Inputs and outputs
13	Auxiliary inputs
14	Alarm outputs
15	Maintenance
16	Hour meters
17	Therm. Compressors
18	Economizer
19	Individual Pressure Switch
20	Individual Thermostat
21	Pump control
22	Antifreeze
23	Date and time

- 1** – **Access control:**
According to the access level, the user can take different action on the **RCK-862_{plus}**. You can adjust 3 access levels:
- Viewer:
Standard mode, there is no need to enter code.
- Technical:
Allows you to make changes to some system parameters.
Technical level is activated by entering code 123.
- Administrator:
Allows you to make changes to all system parameters (normally used when performing the initial system configuration).
Administrator level is activated by entering code 717.
In an invalid code is entered or the **RCK-862_{plus}** is idle for 15 minutes, it automatically returns to Viewer mode.
- 2** – **Control status:**
You can turn the system control on or off **RCK-862_{plus}** only monitors the system but without taking any action.
Note: Changing some functions such as downloading presets requires that the controller be turned off.
Suction control:
Allows manual control of the suction on/off.
Note: The shutdown is performed according to the compressor shutdown times and involves fluid recovery if configured.
- 3** – **Thermostat Control:**
Allows manual control of the thermostats on and off.
- 4** – **Resetting alarms:**
Reset the pressure switches in manual or automatic reset condition. Once the resetting is done, this will be recorded in the alarm history.
- 5** – **Setpoint Adjustment:**
Allows adjustment of the suction line control setpoint with the 'Viewer' user level, i.e., without the need for an access password. This option is only available if function 2.6 (Setpoint adjustment in the control menu) is enabled.
- 6** – **Economic setpoint:**
Activates the economic setpoint for each group of pressure switches.
- 7** – **Pump Down:**
Activates the Pump Down function for each group of pressure switches.
- 8** – **Manual defrost:**
Allows manual activation and deactivation of the defrost process for thermostats and suction lines.
- 9** – **Adiabatic Condensation:**
Enables and disables adiabatic condensation logic for each discharge pressure switch.
- 10** – **Dynamic condensation:**
Enables and disables dynamic condensation logic for each discharge pressure switch
- 11** – **Inputs and outputs:**
A summary of the **RCK-862_{plus}** inputs and outputs is displayed, indicating the sensor reading value, the status of the digital inputs and control outputs.
- 12** – **Auxiliary inputs:**
It displays the status of the configured auxiliary inputs.
- 13** – **Alarm outputs:**
View the status of configured alarm outputs.
- 14** – **Maintenance:**
Compressors or fans are viewed and selected to enter maintenance mode. When the equipment is in the maintenance state, it remains off.
- 15** – **Hour meters:**
Indicates the number of hours that each compressor or fan has remained in operation.
- 16** – **Compressor protection thermostat:**
View of compressor protection thermostats.
- 17** – **Economizer:**
View the information of the economizer logics.
- 18** – **Individual pressure switch:**
View of the summary screens of the individual pressure switches.
- 19** – **Individual thermostat:**
View of the summary screens of the individual pressure switches.
- 20** – **Pump control:**
View suction line pump control information.
- 21** – **Antifreeze:**
View the information of the Antifreeze logics.
- 22** – **Date and time:**
Adjusts the current date and time. This field is important for alarm and logic records that use a clock.
- 23** –

14. REFRIGERATION GROUP

14.1 Suction control:

O **RCK-862 plus** Allows the assignment of links between suction and discharge lines. These links are formed by creating groups, which are sets of suction and discharge lines. Some commands via menu and digital inputs can be assigned to the groups. Additionally, alarms that occur in the discharge line affect the suction lines of the same group by shutting down compressors. The discharge lines are fixed and belong to groups with the same index: discharge 1 to group 1, discharge 2 to group 2, and discharge 3 to group 3.

Examples of groups:

Two groups with one suction and one discharge each:

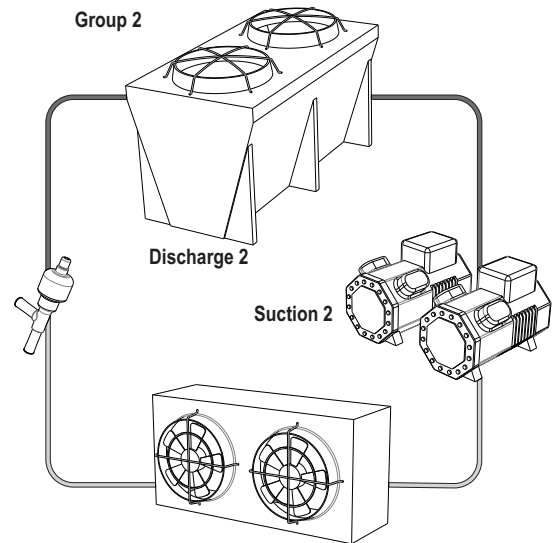
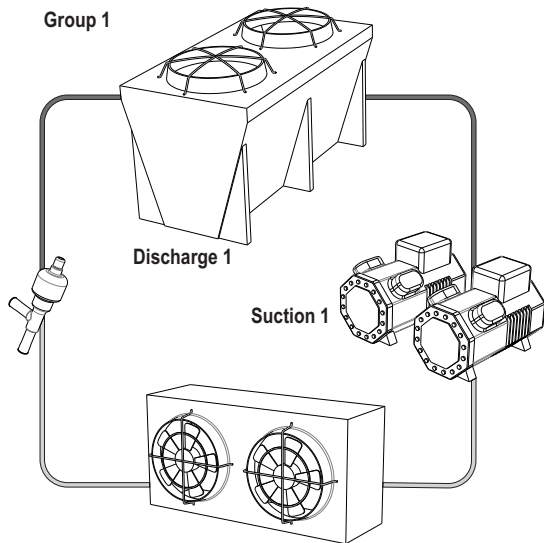

- 1 . 1 . 2 Number of suction pressure switches = 2
- 1 . 1 . 3 Number of discharge pressure switches = 2
- 1 . 1 . 5 Suction group 1 = Group 1
- 1 . 1 . 6 Suction group 2 = Group 2
- 1 . 1 . 8 Group 1 cooling fluid = R404A
- 1 . 1 . 9 Group 2 cooling fluid = R410A

Group 1 with two suctions and one discharge and group 2 with one suction and one discharge:

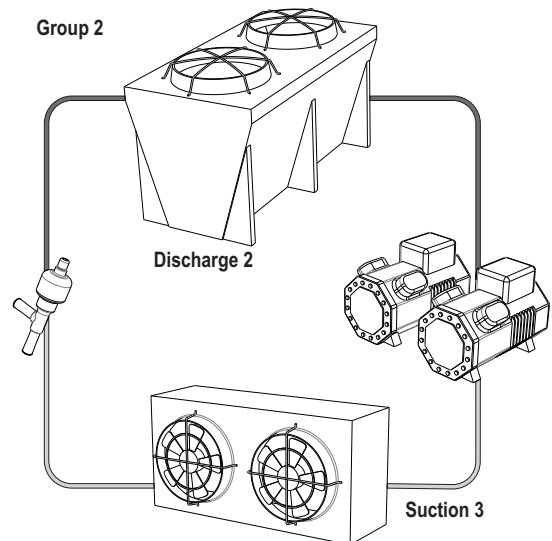
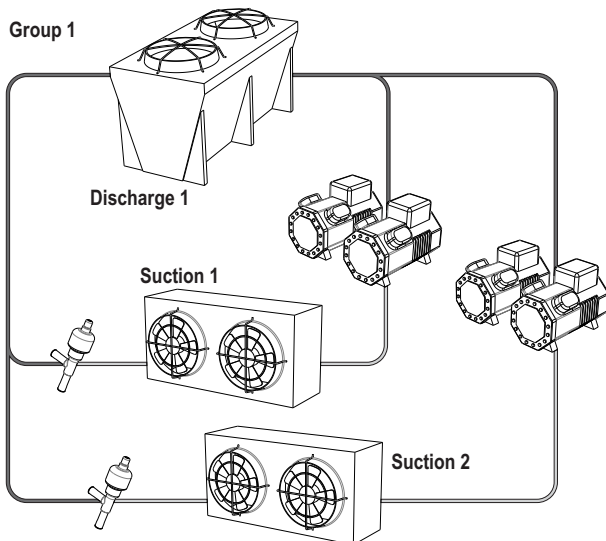

- 1 . 1 . 2 Number of suction pressure switches = 3
- 1 . 1 . 3 Number of discharge pressure switches = 2
- 1 . 1 . 5 Suction group 1 = Group 1
- 1 . 1 . 6 Suction group 2 = Group 1
- 1 . 1 . 7 Suction group 3 = Group 2
- 1 . 1 . 8 Group 1 cooling fluid = R404A
- 1 . 1 . 9 Group 2 cooling fluid = R410A

14. REFRIGERATION GROUP

In addition to the linkage created by the groups, it is possible to enable synchronization between two suction lines. If synchronization between suction 1 and 2 is enabled (1.1.28). Suction 2 is forced to operate at minimum capacity before the first compressor of suction 1 starts. In case of a shutdown due to an alarm in suction 2, suction 1 is also shut down. The same applies to suction 1 and 3 (1.1.27) and suction 2 and 3 (1.1.28).

Application Example:

Cascade circuit configuration with one group operating at low and medium pressure and another at high pressure. Suction 3 should start before suction 1 or 2, and alarms that shut down compressors in suction 2 affect all 3 lines

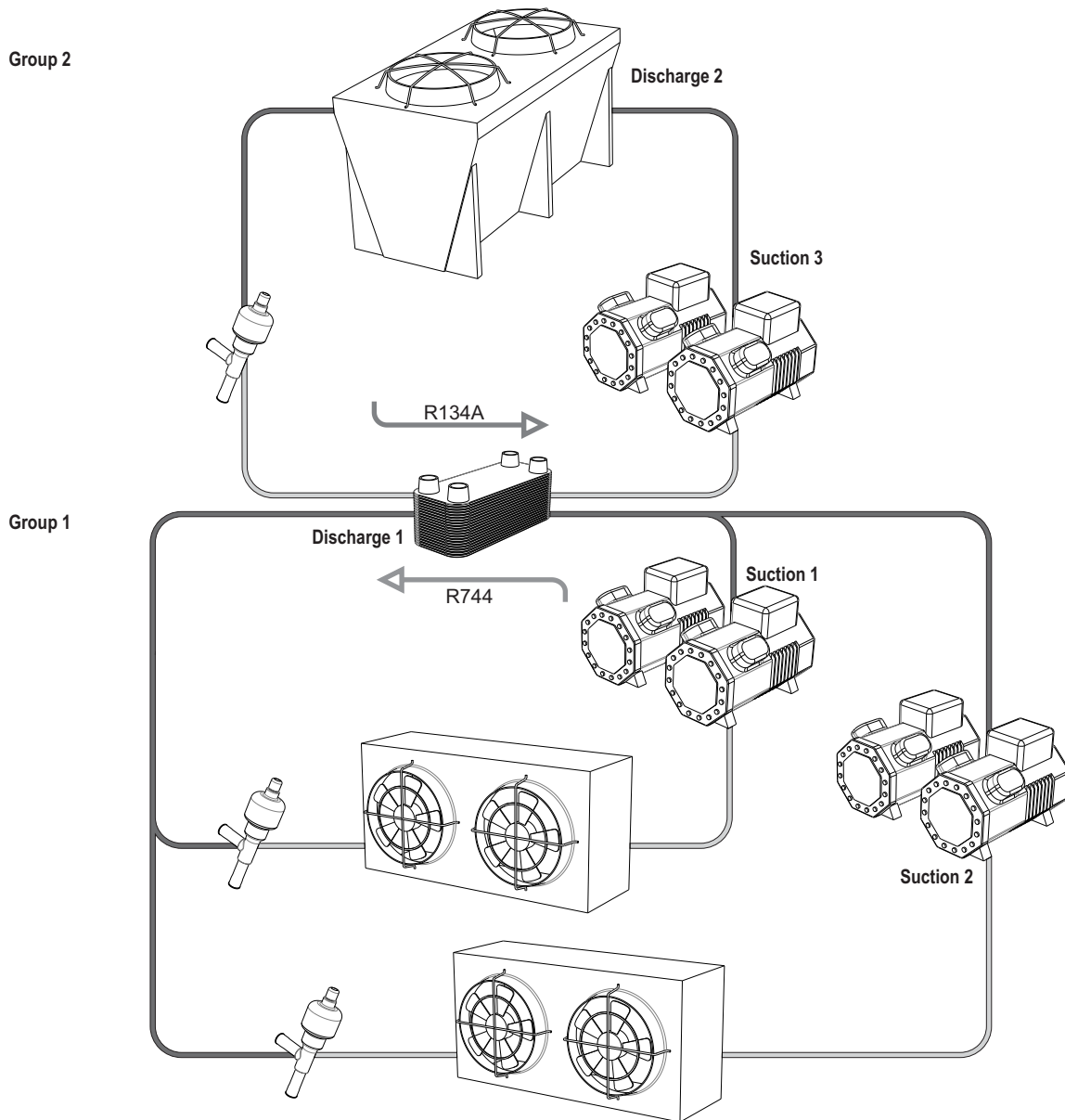

- 1.1.2 Number of suction pressure switches = 3
- 1.1.3 Number of discharge pressure switches = 2
- 1.1.5 Suction group 1 = Group 1
- 1.1.6 Suction group 2 = Group 1
- 1.1.7 Suction group 3 = Group 2
- 1.1.8 Group 1 cooling fluid = R744
- 1.1.9 Group 2 cooling fluid = R134A
- 1.1.27 Synchronization between suction 1 and suction 3 = Yes
- 1.1.28 Synchronization between suction 2 and suction 3 = Yes

15.SUCTION CONTROLS

15.1 Suction Control:

Suction control parameters are adjusted in the following Menu: **Main Menu** → **Function Configuration** → **Suction**.

Compressor control is associated with a suction pressure switch. The **RCK-862 plus** enables control of up to 3 suction pressure switches with up to 6 compressors each. The digital outputs, indicated as O1, O2..., O6, are responsible for the On/Off control of compressors and unloaders, while the analog outputs, indicated as A1 and A2, provide a 0-10V signal for frequency inverters or other devices. The **RCK-862 plus** controls up to three unloaders per compressor and features a control mode for variable compressors such as the Bitzer CR11.

Note: Alarms on the discharge pressure switches may also affect the suction compressors as per the alarm table.

15.2 Compressor On/Off Modulation:

Each compressor manufacturer has its own mode of capacity control for their compressors. The most common compressors have two operating stages: on or off. In this case, On/Off modulation is used. For compressors with the ability to regulate their capacity through step-type unloader valve actuations, select the type according to the options below:

On/Off - Compressor with on/off operation using a single digital output (relay) for activation.

On/Off 50 | 100 - Associates a main output and an auxiliary output for 3-stage compressor control.

On/Off 33 | 66 | 100 - Associates a main output and 2 auxiliary outputs for 4-stage compressor control.

On/Off 50 | 75 | 100 - Associates a main output and 2 auxiliary outputs for 4-stage compressor control.

On/Off 25 | 50 | 75 | 100 - Associates a main output and 3 auxiliary outputs for 5-stage compressor control.

Associated with On/Off compressor modulation is an Activation Mode (1 . 2 . 1 . 44 - (49)) that determines the sequence of control outputs according to the compressor's construction. The main output, which is the first to turn on and the last to turn off, is typically used to activate the compressor motor. Auxiliary outputs are typically used to activate or deactivate an unloader valve for compressor capacity regulation. The **RCK-862 plus** has 3 activation modes as shown in the table below:

Incremental Mode					Unloader Mode					Selective Mode				
Modulation ON/OFF 50 100					Modulation ON/OFF 50 100					Modulation ON/OFF 50 100				
Capacity	Main	Aux 1	Aux 2	Aux 3	Capacity	Main	Aux 1	Aux 2	Aux 3	Capacity	Main	Aux 1	Aux 2	Aux 3
Off	○	○	-	-	Off	○	○	-	-	Off	○	○	-	-
50%	●	○	-	-	50%	●	●	-	-	50%	●	●	-	-
100%	●	●	-	-	100%	●	○	-	-	100%	●	○	-	-
Modulation ON/OFF 33 66 100					Modulation ON/OFF 33 66 100					Modulation ON/OFF 33 66 100				
Capacity	Main	Aux 1	Aux 2	Aux 3	Capacity	Main	Aux 1	Aux 2	Aux 3	Capacity	Main	Aux 1	Aux 2	Aux 3
Off	○	○	○	-	Off	○	○	○	-	Off	○	○	○	-
33%	●	○	○	-	33%	●	●	●	-	33%	●	●	○	-
66%	●	●	○	-	66%	●	●	○	-	66%	●	○	●	-
100%	●	●	●	-	100%	●	○	○	-	100%	●	○	○	-
Modulation ON/OFF 50 75 100					Modulation ON/OFF 50 75 100					Modulation ON/OFF 50 75 100				
Capacity	Main	Aux 1	Aux 2	Aux 3	Capacity	Main	Aux 1	Aux 2	Aux 3	Capacity	Main	Aux 1	Aux 2	Aux 3
Off	○	○	○	-	Off	○	○	○	-	Off	○	○	○	-
50%	●	○	○	-	50%	●	●	●	-	50%	●	●	○	-
75%	●	●	○	-	75%	●	●	○	-	75%	●	○	●	-
100%	●	●	●	-	100%	●	○	○	-	100%	●	○	○	-
Modulation ON/OFF 25 50 75 100					Modulation ON/OFF 25 50 75 100					Modulation ON/OFF 25 50 75 100				
Capacity	Main	Aux 1	Aux 2	Aux 3	Capacity	Main	Aux 1	Aux 2	Aux 3	Capacity	Main	Aux 1	Aux 2	Aux 3
Off	○	○	○	○	Off	○	○	○	○	Off	○	○	○	○
25%	●	○	○	○	25%	●	●	●	●	25%	●	●	○	○
50%	●	●	○	○	50%	●	●	●	○	50%	●	○	●	○
75%	●	●	●	○	75%	●	●	○	○	75%	●	○	○	●
100%	●	●	●	●	100%	●	○	○	○	100%	●	○	○	○

Key:

- - Output on
- - Output off

Example: For a compressor with two unloaders, where each valve removes 33.3% of the compressor's capacity, the compressor modulation can be selected as On/Off 33 | 66 | 100 (parameter 1 . 2 . x . 38 - (43)). One output is defined for the compressor motor, associated with the main output (1 . 2 . x . 53), and two auxiliary outputs for the unloader valves (1 . 2 . x . 54 e 1 . 2 . x . 55) The behavior of the auxiliary outputs is defined by the parameter "Compressor Activation Mode" (1 . 2 . x . 44 - (49)).

In the "Incremental Mode", when only the main compressor output is activated, the controller assumes that the compressor operates at 33.3% of its capacity. Activating Auxiliary Output 1 will increase the capacity to 66.6%, and activating Auxiliary Output 2 will set the capacity to 100% of the compressor's nominal capacity.

In the "Unloader Mode", when the compressor output is activated, the controller assumes that the compressor operates at 100% of its capacity. Activating Auxiliary Output 1 will set the capacity to 66.6%, and when the second auxiliary output is activated, the capacity will be 33.3% of the nominal capacity.

In the "Selective Mode", when only the main compressor output is activated, the controller assumes that the compressor operates at 100% of its capacity. Activating Auxiliary Output 2 will set the capacity to 66.6%, and when Auxiliary Output 2 is deactivated and Auxiliary Output 1 is activated, the capacity will be 33.3% of the nominal capacity.

15.SUCTION CONTROLS

15.3 Modulation of Variable Capacity Compressors (VCC):

Variable Capacity Compressors (VCC) are compressors controlled by means of an analog output (VCC-Analog) or by means of fast-acting digital outputs (VCC-Digital).

Only Compressor 1 of each suction pressure switch can be configured as VCC, and when operating in conjunction with On/Off compressors, it is the first to turn on and the last to turn off.

15.3.1 VCC-Analog:

To control a variable capacity compressor using the analog output, use a 0-10V analog output (1.2.x.52) and optionally a digital output for Start/Stop (1.2.x.53).

15.3.2 VCC-Digital:

To control a digital VCC compressor, a digital output must be configured for motor activation and one or more fast switching outputs (SSR) for controlling capacity modulation valves. During compressor operation, only one valve is modulated, while the others remain either on or off. The choice of which valve to modulate is automatically made by the controller, based on the valve with the fewest activations, thereby increasing the lifespan of the system. The compressor starts when the required capacity exceeds the configured VCC: Minimum Capacity value (1.2.x.84) and continues to run unloaded until the configured VCC: Startup Capacity Time (1.2.x.88).

The **RCK-862 plus** algorithm automatically determines when auxiliary outputs should be activated. If fixed time intervals for valve control are desired, the desired period should be selected in the VCC-Digital: Control Period parameter (1.2.x.92).

Each digital compressor manufacturer sets limitations for the minimum activation time of the modulation valves, which can be configured in VCC-Digital: Minimum Valve Activation Time (1.2.x.93).

The **RCK-862 plus** allows for control of various digital compressor configurations, supporting modulation for compressors with one to three auxiliary control valves. The correct selection should match the compressor's characteristics, as follows:

VCC-Digital 10-100 1V: One main output for compressor activation and one digital output (SSR) for auxiliary valve modulation. The main output represents 0% of the compressor's capacity.

VCC-Digital 10-100 2V: One main output for compressor activation and two digital outputs (SSR) for modulation of two auxiliary valves. The main output represents 0% of the compressor's capacity.

VCC-Digital 10-100 3V: One main output for compressor activation and three digital outputs (SSR) for modulation of three auxiliary valves. The main output represents 0% of the compressor's capacity.

VCC-Digital 33-100 1V: One main output for compressor activation and one digital output (SSR) for auxiliary valve modulation. The main output represents 33% of the compressor's capacity.

VCC-Digital 33-100 2V: One main output for compressor activation and two digital outputs (SSR) for modulation of two auxiliary valves. The main output represents 33% of the compressor's capacity.

VCC-Digital 50-100 1V: One main output for compressor activation and one digital output (SSR) for auxiliary valve modulation. The main output represents 50% of the compressor's capacity. The following table illustrates the behavior of outputs relative to the required compressor capacity, without considering output rotation.

VCC-Digital 10-100 2V_B: One main output for compressor activation, one digital output (SSR) for modulation of a valve corresponding to 50% of the compressor's capacity, and one digital output for an unloader valve corresponding to 50% of the compressor's capacity. The main output represents 0% of the compressor's capacity.

VCC-Digital 10-100 3V_B: One main output for compressor activation, one digital output (SSR) for modulation of a valve corresponding to 33% of the compressor's capacity, and two digital outputs for unloader valves, each corresponding to 33% of the compressor's capacity. The main output represents 0% of the compressor's capacity.

15.SUCTION CONTROLS

Modulation of VCC-Digital compressors

Modulation VCC-Digital 10-100 1V					Modulation VCC-Digital 33-100 1V					Modulation VCC-Digital 50-100 1V				
Capacity	Main	Aux 1	Aux 2	Aux 3	Capacity	Main	Aux 1	Aux 2	Aux 3	Capacity	Main	Aux 1	Aux 2	Aux 3
Off	○	○	-	-	Off	○	○	-	-	Off	○	○	-	-
Startup	●	●	-	-	Startup	●	●	-	-	Startup	●	●	-	-
10-100%	●	◐	-	-	33-100%	●	◐	-	-	50-100%	●	◐	-	-
>100%	●	○	-	-	>100%	●	○	-	-	>100%	●	○	-	-

Modulation VCC-Digital 10-100 2V					Modulation VCC-Digital 33-100 2V					Modulation VCC-Digital 10-100 3V				
Capacity	Main	Aux 1	Aux 2	Aux 3	Capacity	Main	Aux 1	Aux 2	Aux 3	Capacity	Main	Aux 1	Aux 2	Aux 3
Off	○	○	○	-	Off	○	○	○	-	Off	○	○	○	○
Startup	●	●	●	-	Startup	●	●	●	●	Startup	●	●	●	●
10-50%	●	◐	●	-	33%	●	◐	●	-	10-33%	●	◐	●	●
50-100%	●	○	◐	-	66%	●	○	◐	-	33-66%	●	○	◐	●
>100%	●	○	○	-	100%	●	○	○	-	66-100%	●	○	○	◐

Modulation VCC-Digital 10-100 2V_B					Modulation VCC-Digital 10-100 3V_B				
Capacity	Main	Aux 1	Aux 2	Aux 3	Capacity	Main	Aux 1	Aux 2	Aux 3
Off	○	○	○	-	Off	○	○	○	○
Startup	●	●	●	-	Startup	●	●	●	●
10-50%	●	◐	●	-	10-33%	●	◐	●	●
50-100%	●	◐	○	-	33-66%	●	◐	●	○
>100%	●	○	○	-	66-100%	●	◐	○	○
					>100%	●	○	○	○

Key:

- - Output on
- - Output off
- ◐ - Modulated output

Note: It is assumed that when a valve is activated, the controlled element operates without load and the compressor capacity is reduced.

15.3.3 Screw compressor with slide valve:

For controlling screw compressors with a slide valve, the option VCC-25|50|75|100|S must be selected. In this configuration, auxiliary outputs 1 to 3 select the slide valve position for capacities of 75%, 50%, and 25%, respectively. Auxiliary output 4 controls the oil flow, turning on and off at intervals defined by parameters 1.2.x.101 and 1.2.x.102. Auxiliary output 3 remains on after the compressor shuts down, causing the slide valve to return to its original position.

Modulation VCC - 25 50 75 100 S					
Capacity	Main	Aux 1	Aux 2	Aux 3	Aux 4
Off	○	○	○	●	○
Startup	●	○	○	●	○
25%	●	○	○	●	◐
50%	●	○	●	○	◐
75%	●	●	○	○	◐
100%	●	○	○	○	◐

Note: Operating the compressor below the minimum capacity allowed by the manufacturer can cause irreversible damage. Therefore, it is essential to consult the compressor manufacturer regarding the minimum operating capacity and configure the minimum value in function 1.2.x.84 (VCC: Minimum Capacity).

15.4 Control Modes:

Each suction pressure switch can be programmed, in parameter 1.2.x.1, to operate according to one of the Control Modes: Linear Mode, Rotation Mode, Dead Zone Mode, Dead Zone Mode with rotation and Progressive Algorithm Mode.

15.4.1 Linear Mode:

Linear mode is applied when using compressors of the same capacity, combined or not with a compressor with proportional modulation (inverter). Compressors and their unloader valves are activated (if configured) sequentially and at equal pressure intervals. It follows the ascending order according to its nomenclature and shutdown.

15.4.1.1 Linear mode connected only with digital outputs - ON/OFF compressors + Unloaders

The Linear Control Mode, when associated with only digital outputs, controls the sequential activation and deactivation of each compressor with pressure intervals of the same magnitude (step). The **RCK-862 plus** uses a setpoint value and pressure hysteresis for suction control of the compressors. If the compressors have unloader valves (auxiliary outputs), the activation and deactivation sequence can be selected according to parameters 1.2.x.50 and 1.2.x.51

Digital outputs are associated with compressors in the **Main Menu** → **1.Function Settings** → **1.2 Suction**. The **RCK-862 plus** determines the activation and deactivation points based on the hysteresis value and the number of compressors configured for suction, according to the "step" variable defined below:

$$\text{Step} = \frac{\text{Digital hysteresis}}{\text{Number of outputs}}$$

Actuation output pressure value for output "N"
 Actuation = Setpoint + (N x Step)

Shutdown output pressure value of output "N"
 Actuation = Setpoint + (N - 1 x Step)

15.SUCTION CONTROLS

Example: Linear control linked only with ON-OFF compressors

ON/OFF compressors only

When using on / off compressors (ON / OFF), each compressor is associated with only one output, so the Step is equal to hysteresis by dividing the number of compressors

- | | |
|--|--|
| 1.2.x.1 Control mode: Linear | 1.2.x.39 Compressor 2 modulation: ON/OFF |
| 1.2.x.3 Setpoint: 25psi | 1.2.x.40 Compressor 3 modulation: ON/OFF |
| 1.2.x.5 On/Off Hysteresis: 6psi | 1.2.x.41 Compressor 4 modulation: ON/OFF |
| 1.2.x.31 Number of compressors: 6 | 1.2.x.42 Compressor 5 modulation: ON/OFF |
| 1.2.x.38 Compressor 1 modulation: ON/OFF | 1.2.x.43 Compressor 6 modulation: ON/OFF |

In this case, each compressor is associated with a digital output and the Step is defined as 6/6 = 1 psi

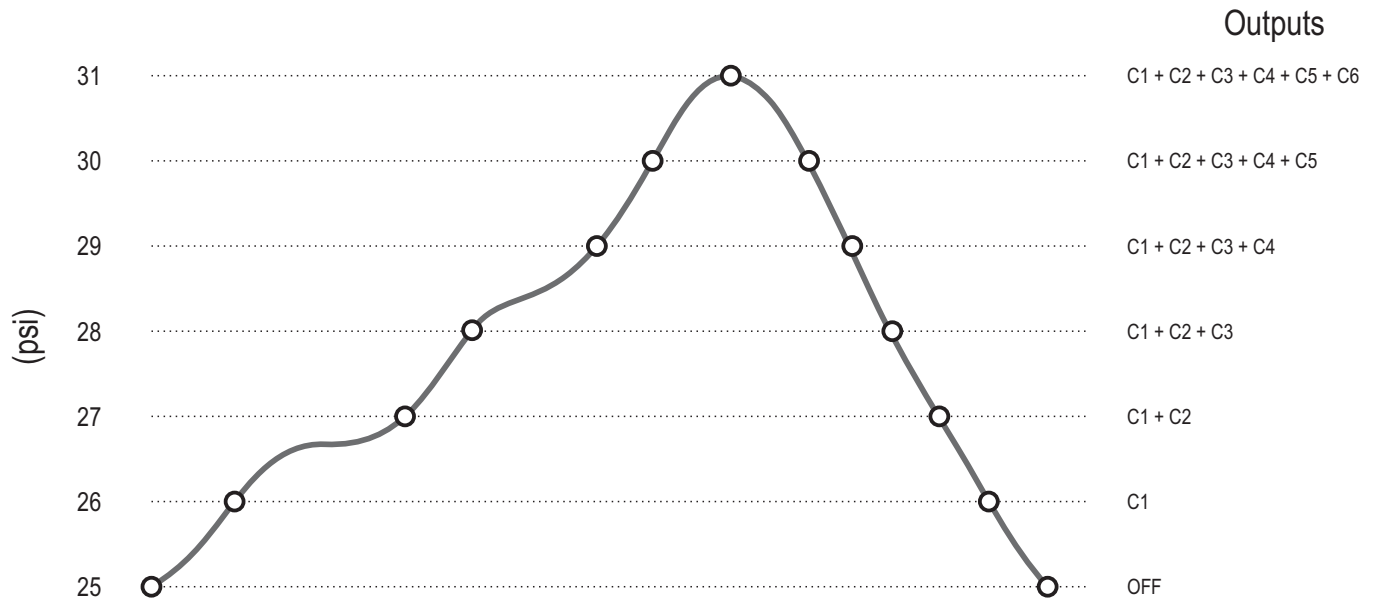

Example: Linear control linked with digital outputs from compressors with unloaders

On/Off compressors with unloaders.

In the compressors that use the unloader capacity regulation valve, the logic for actuating and shutting down the main relays and auxiliary unloader valves is chosen according to parameters 1.2.x.50 - Sequence of actuations and 1.2.x.51 - Sequencing of shutdowns.

- | | |
|--|--|
| 1.2.x.1 Control mode: Linear | 1.2.x.39 Compressor 2 modulation: On/Off 50 100 |
| 1.2.x.3 Setpoint: 25psi | 1.2.x.40 Compressor 3 modulation: On/Off 33 66 100 |
| 1.2.x.4 On/Off Hysteresis: 6psi | 1.2.x.45 Compressor 2 activation mode: Incremental |
| 1.2.x.31 Number of compressors: 3 | 1.2.x.46 Compressor 3 activation mode: Incremental |
| 1.2.x.38 Compressor 1 modulation: ON/OFF | 1.2.x.50 Activation sequence: PPuu |
| | 1.2.x.51 Deactivation sequence: Ppuu |

Compressor 1 is of the ON/OFF type and requires only one digital output connected to it. Compressor 2 has an unloader valve, so it is connected to two digital outputs (main and auxiliary 1). Compressor 3 has two unloader valves, so it is connected to three digital outputs (main, auxiliary 1 and auxiliary 2). The total number of digital outputs is six and its step is defined as: 6/6 = 1 psi.

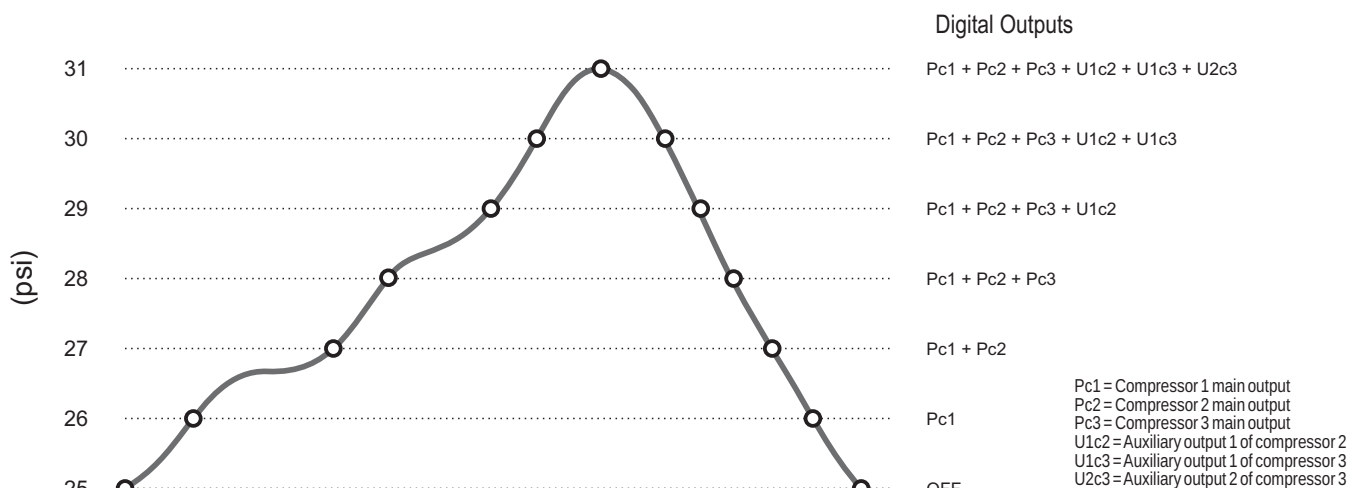

Pc1 = Compressor 1 main output
Pc2 = Compressor 2 main output
Pc3 = Compressor 3 main output
U1c2 = Auxiliary output 1 of compressor 2
U1c3 = Auxiliary output 1 of compressor 3
U2c3 = Auxiliary output 2 of compressor 3

15.SUCTION CONTROLS

15.4.1.2 Linear Mode associated with a VCC compressor in conjunction with ON/OFF compressors:

When the VCC compressor, either analog or digital, operates in conjunction with On/Off compressors - whether with unloaders or not - the control is managed through a setpoint value and two hysteresis values. The hysteresis of the VCC compressor (1.2.x.6) corresponds to the pressure interval for controlling the output of compressor 1, while the hysteresis of the On/Off compressors (1.2.x.5) corresponds to the control interval for the remaining compressors.

The VCC compressor is the first to be activated and the last to be deactivated. There is a validation time (1.2.x.91) for activation or (1.2.x.90) deactivation of compressors or unloader valves when the compressor reaches its upper or lower operating limit. For each compressor or unloader activated or deactivated, the capacity of the VCC compressor is recalculated to compensate for the added or removed portion.

Example:

- | | |
|---------------------------------|--|
| 1.2.x.1 Control mode: Linear | 1.2.x.31 Number of compressors: 3 |
| 1.2.x.3 Setpoint: 25psi | 1.2.x.38 Compressor 1 modulation: VCC-Analog |
| 1.2.x.5 Hysteresis On/Off: 4psi | 1.2.x.39 Compressor 2 modulation = On/Off |
| 1.2.x.6 VCC hysteresis: 2psi | 1.2.x.40 Compressor 3 modulation = On/Off |

Compressor 1 (proportional) uses analog output (0-10V), compressors 2 and 3 each use a digital output. The step of the digital outputs is defined as: 4/2 = 2psi.

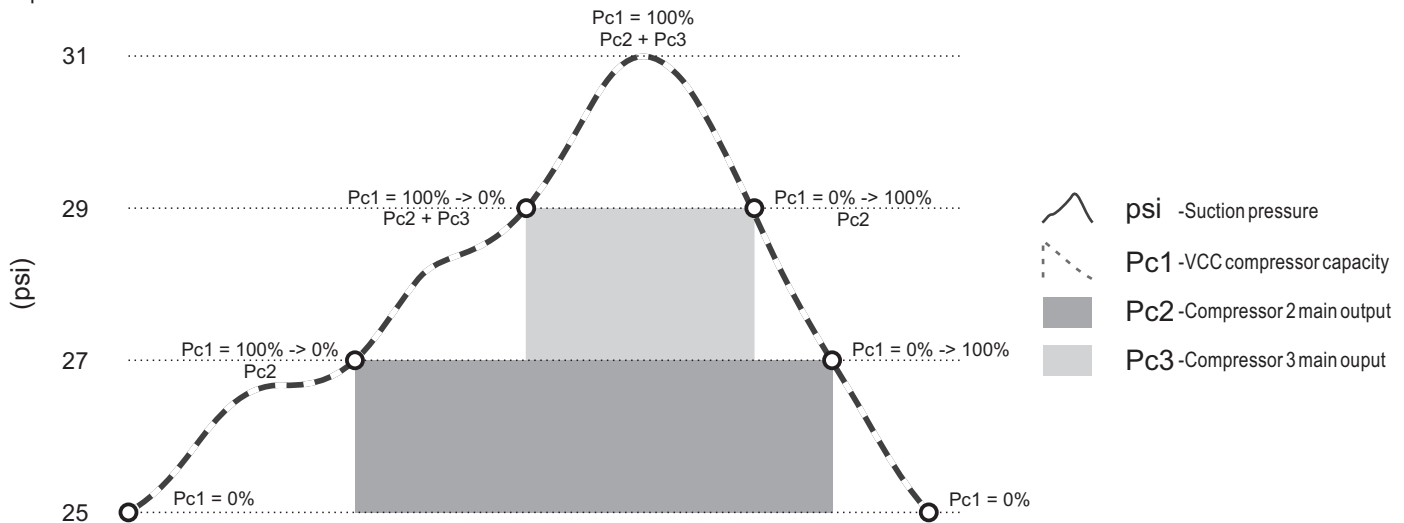

15.4.1.3 Linear mode connected to a VCC-Analog compressor:

The VCC-Analog is used to drive frequency inverters or modules to control compressors that receive a signal between 0-10V. The control uses the parameters of the setpoint value and the hysteresis of the VCC compressor. It is also possible to connect a digital input for the Start-stop output of the VCC compressor.

Example

- | | |
|---|--|
| 1.2.x.1 Control mode: Linear | 1.2.x.53 Compressor 1 start-stop main output: O1 |
| 1.2.x.6 Setpoint: 25psi | 1.2.x.88 VCC: Start Capacity Time: 60s |
| 1.2.x.6 VCC hysteresis: 6psi | 1.2.x.84 VCC: Minimum Capacity: 10% |
| 1.2.x.31 Number of compressors: 1 | 1.2.x.85 VCC: Maximum Capacity: 100% |
| 1.2.x.38 Modulation of compressor 1: VCC-Analog | 1.2.x.86 VCC: Minimum Start Capacity: 15% |
| 1.2.x.52 Compressor 1 analog output: A1 | |

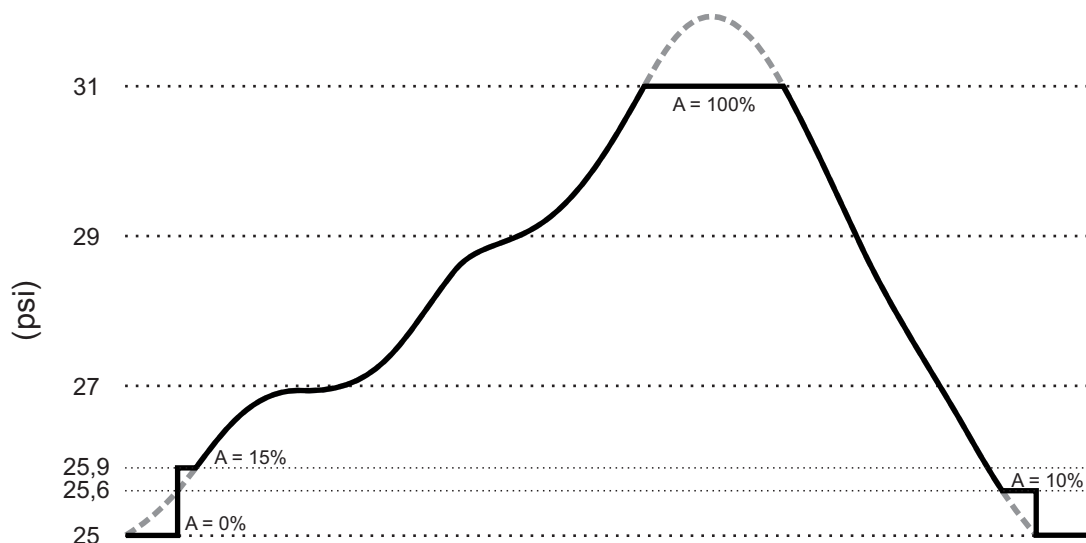

15.SUCTION CONTROLS

15.4.1.4 Linear mode connected to a VCC-Digital compressor.

The VCC-Digital is used to control compressors with capacity modulation through solenoid valves. The control is based on the setpoint value and the hysteresis of the VCC compressor.

Example: Compressor with modulation through 2 valves, each controlling 50% of the capacity.

1.2.x.1	Control mode: Linear	1.2.x.54	Compressor 1 Auxiliary Output 1: O2
1.2.x.3	Setpoint: 25 psi	1.2.x.55	Compressor 1 Auxiliary Output 2: O3
1.2.x.6	VCC Compressor Hysteresis: 6psi	1.2.x.84	VCC: Minimum Capacity: 10%
1.2.x.31	Number of Compressors: 1	1.2.x.92	VCC-Digital: Control Period: Auto
1.2.x.38	Compressor 1 Modulation: 0110...100 (2V)	1.2.x.93	VCC-Digital: Minimum Valve Activation Time: 5 seconds
1.2.x.53	Compressor 1 Main Output: O1		

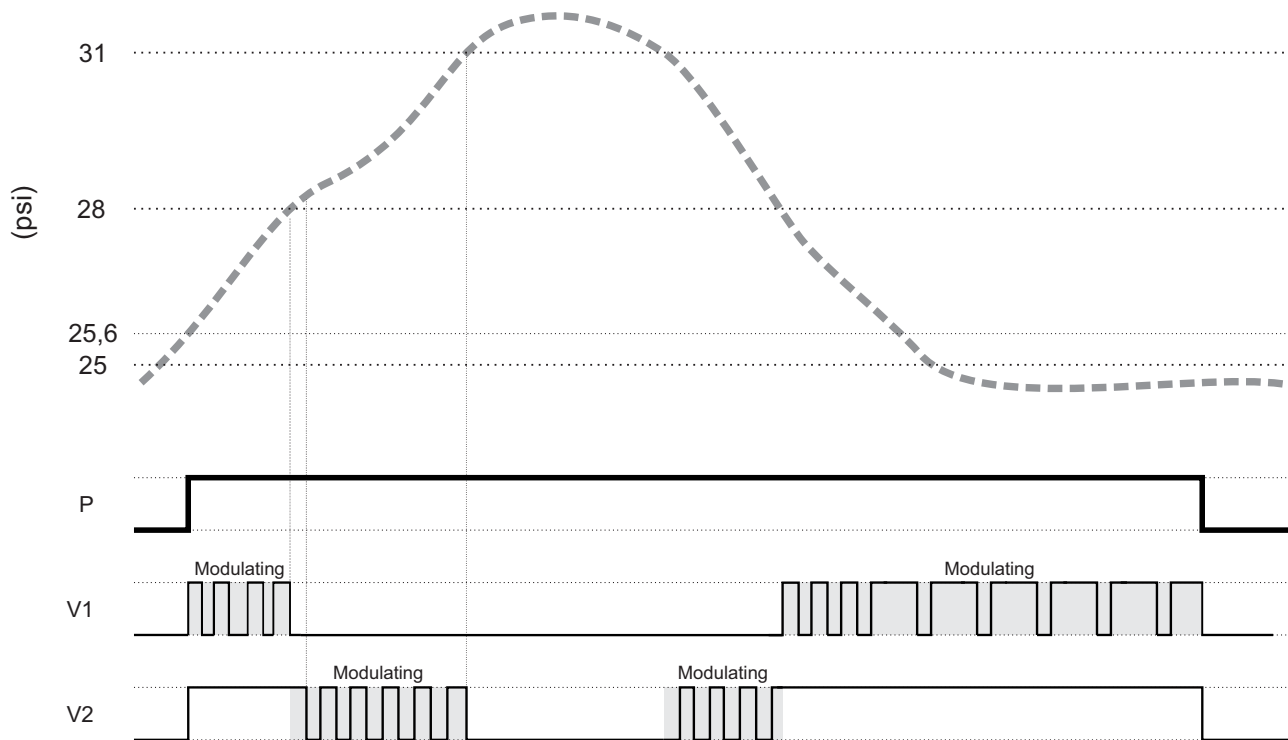

15.4.2 Rotation Mode:

This mode operates similarly to the Linear Mode but performs a clockwise rotation for the activation and deactivation of compressors based on the recorded operating hours of each compressor. When the control system recognizes the need to activate a compressor, it preferentially activates the compressor with the lowest recorded number of full operating hours. Similarly, when deactivating a compressor, it preferentially deactivates the compressor with the highest number of full operating hours. The operating hours of each compressor can be viewed in the Control Menu under the "Hour Meters" option. In this menu, you can reset one (select the compressor and press **SET**) or all (hold **SET** for 2 seconds) of the operation time records.

Since the VCC compressor is always the first to start and the last to stop, it is not included in the rotation; hence, the rotation is only applied to compressors associated with digital outputs.

15.SUCTION CONTROLS

15.4.3 Dead zone mode:

Dead band control involves defining a regulation band around the setpoint where the control action remains fixed, except for VCC compressors. The control system operates differently across the three distinct operating ranges: above, within, and below the dead band. The dead band region is defined by the parameters Lower dead band differential (1.2.x.8 or 1.2.x.17) and Upper dead band differential (1.2.x.9 or 1.2.x.18). Above the dead band the compressors are activated respecting the time between compressor activations (1.2.x.78). Within the dead band the number of active compressors remains constant, and only the capacity of the VCC compressor is modulated. The VCC compressor reaches its minimum capacity when the control variable is at the lower dead band differential and its maximum capacity at the upper dead band differential. Below the dead band the compressor deactivation occurs either respecting the time between compressor deactivations (1.2.x.79) or immediately if pressure or temperature deviates significantly from the setpoint.

Example:

- | | |
|--|---|
| 1.2.x.1 Control mode: Dead band | 1.2.x.38 Compressor 1 modulation: VCC -Analogic |
| 1.2.x.2 Setpoint: 30psi | 1.2.x.39 Compressor 2 modulation: On /Off |
| 1.2.x.8 Lower dead zone differential: 10,0 psi | 1.2.x.40 Compressor 3 modulation: On /Off |
| 1.2.x.9 Upper dead zone differential: 10,0 psi | 1.2.x.41 Compressor 4 modulation: On /Off |
| 1.2.x.31 Number of compressors: 4 | 1.2.x.78 Time between actuations: 30 seconds |
| | 1.2.x.79 Time between shutdowns: 60 seconds |

Considering the effect of the dead band, no compressor should be activated until the pressure exceeds 40.0 psi. Therefore, Compressors 1 to 3 are only activated when the pressure exceeds this value and respecting the times between activations.

If the pressure decreases, entering the dead band region, the compressors will remain activated until it exceeds the lower dead band differential. One compressor is deactivated immediately, and the others are gradually turned off respecting the time between deactivations.

If the pressure drops rapidly, crossing the instant deactivation ranges, the compressor is deactivated immediately. The step for instant deactivation is defined as:

$$\text{Instant deactivation step} = \text{Lower dead band differential} / (\text{number of active stages} - 1) = 10 / (3 - 1) = 5.$$

Compressor 3 is deactivated when crossing the lower limit of 20 psi, and Compressors 1 and 2 are turned off as follows:

Case 1: If the pressure remains within the range of 20.0 to 15.0 psi. Compressor 2 turns off 60 seconds after Compressor 3, and Compressor 1 turns off 60 seconds after Compressor 2.

Case 2: If the pressure decreases rapidly to the range of 15.0 to 10.0 psi. Compressors 2 and 3 turn off immediately, and Compressor 1 turns off 60 seconds after.

Case 3: If the pressure decreases rapidly to a value below 10.0 psi, all compressors are turned off immediately.

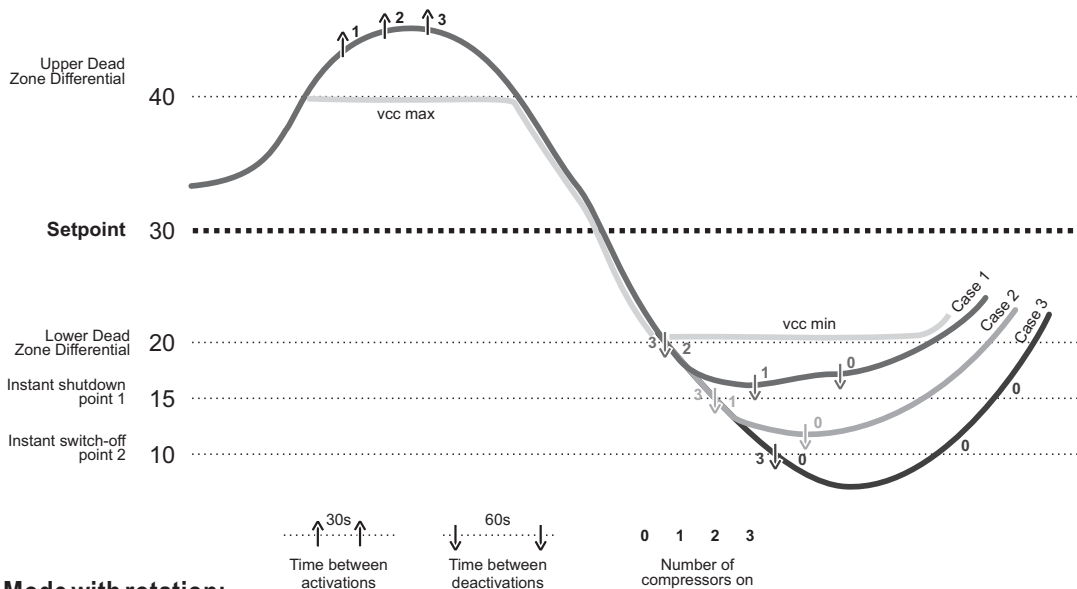

15.4.4 Dead Zone Mode with rotation:

The Dead Zone Control Mode is applied together with the rotation, which is given preference to activate compressors with records of shorter time on and to shutdown compressors with records of longer time on.

15.SUCTION CONTROLS

15.4.5 Progressive algorithm mode:

The Progressive Algorithm is an ideal control mode for systems using compressors of different capacities for suction. The Progressive Algorithm considers the capacities of each compressor to meet the thermal demand of the system, aiming to optimize the use of unloader valves and minimize the number of starts and stops of compressors. This mode can work with up to 6 compressors per suction, with one of them possibly configured as a Variable Capacity Compressor (VCC). When Compressor 1 is configured as VCC, it is the first to be activated and the last to be deactivated. The Progressive Algorithm mode uses a setpoint and a single hysteresis, "AP control mode hysteresis».

Application example:

- 1.2.x.1 Control mode: Progressive Algorithm
- 1.2.x.3 Setpoint: 25psi
- 1.2.x.7 AP Control Mode Hysteresis: 10psi
- 1.2.x.31 Number of compressors: 3
- 1.2.x.32 Compressor 1 capacity: 8kW
- 1.2.x.33 Compressor 2 capacity: 12kW

- 1.2.x.34 Compressor 3 capacity: 20kW
- 1.2.x.38 Compressor 1 modulation: On/Off 50 | 100
- 1.2.x.39 Compressor 2 modulation: On/Off 50 | 100
- 1.2.x.40 Compressor 3 modulation: On/Off 50 | 100
- 1.2.x.44 Compressor 1 activation mode: Incremental
- 1.2.x.45 Compressor 2 activation mode: Incremental
- 1.2.x.46 Compressor 3 activation mode: Incremental

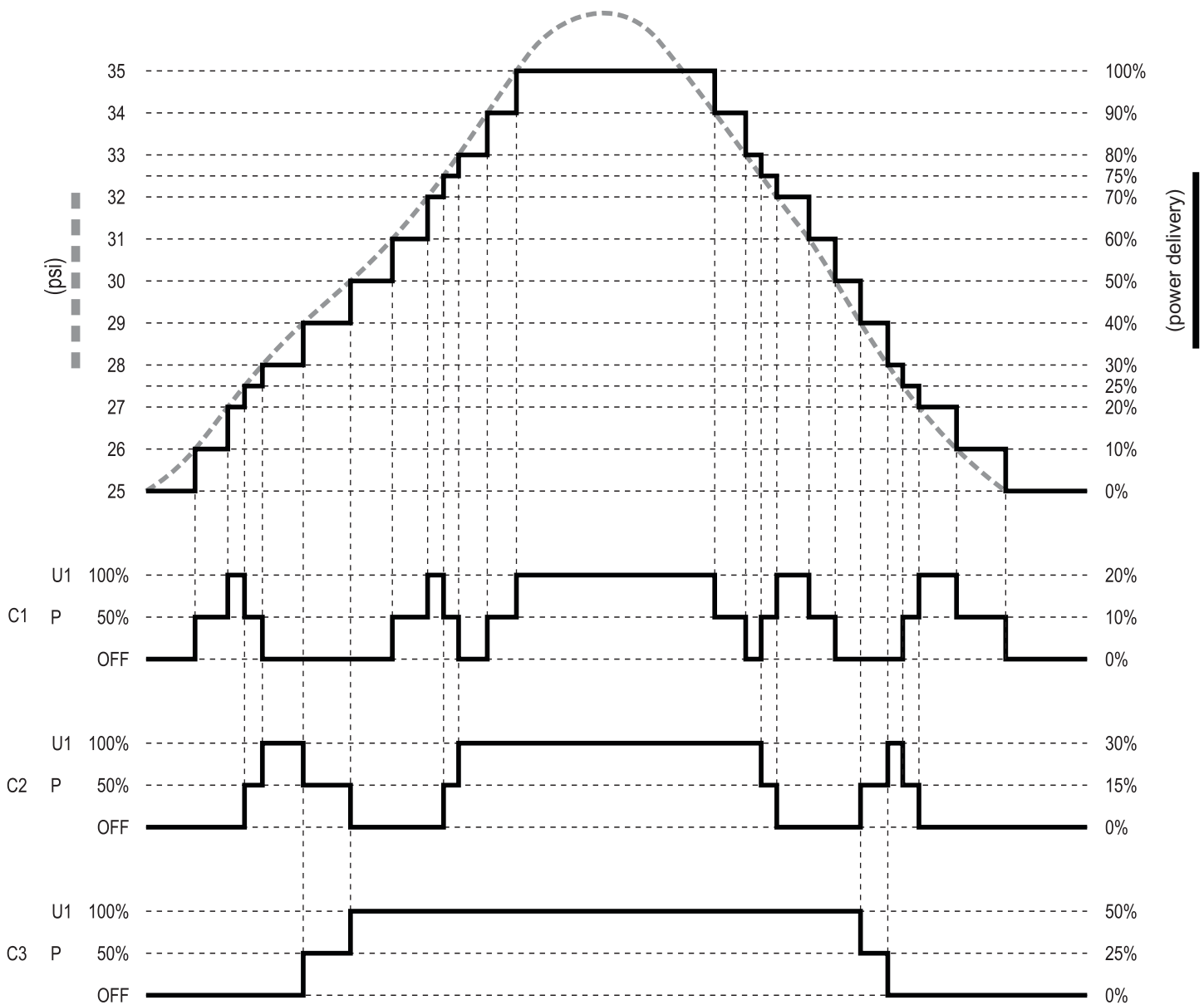

15.SUCTION CONTROLS

15.4.6 Controlling compressors by evaporation temperature:

The **RCK-862 plus** allows compressor control based on the saturation temperature of the refrigerant. This is achieved using the suction pressure sensor reading converted to temperature.

In this type of control, a setpoint and hysteresis values configured in temperature are used (Functions 1.2.x.12 to 1.2.x.20). Pressure readings are considered only for alarm and protection purposes.

To ensure accurate conversion of pressure to saturation temperature, the refrigerant for the corresponding suction line must be configured (1.1.8 for group 1, 1.1.9 for group 2 and 1.1.10 for group 3).

To prevent pressure from reaching low values close to the alarm limit, it is recommended to use the low-pressure shutdown strategy discussed in the following section (15.4.9).

15.4.7 Control by temperature of a secondary fluid:

The **RCK-862 plus** allows compressor control based on the temperature of a secondary fluid, different from the refrigerant in the main refrigeration circuit. This is achieved using temperature sensors measuring the temperature of the fluid of interest.

An example of application is a chilled water refrigeration circuit where, instead of controlling the compressors based on the pressure or saturation temperature of the refrigerant, control is based on the inlet or outlet temperature of a heat exchanger.

In this type of control, a setpoint and hysteresis values configured in temperature are used (Functions 1.2.x.12 to 1.2.x.20). Pressure readings are considered only for alarm and protection purposes.

Two temperature sensors can be configured, labeled as "Inlet Temperature Sensor" and "Outlet Temperature Sensor," and the function 1.2.x.2 determines which sensor will be used for control. In the suction alarm menu (1.4.2.x.7 to 1.4.2.x.10) low and high temperature alarm values for both sensors can be set. To prevent pressure from reaching low values close to the alarm limit, it is recommended to use the low-pressure shutdown strategy discussed in the following section (15.4.9).

Note: This type of control is not permitted in a medium or high-pressure suction in a cascade configuration.

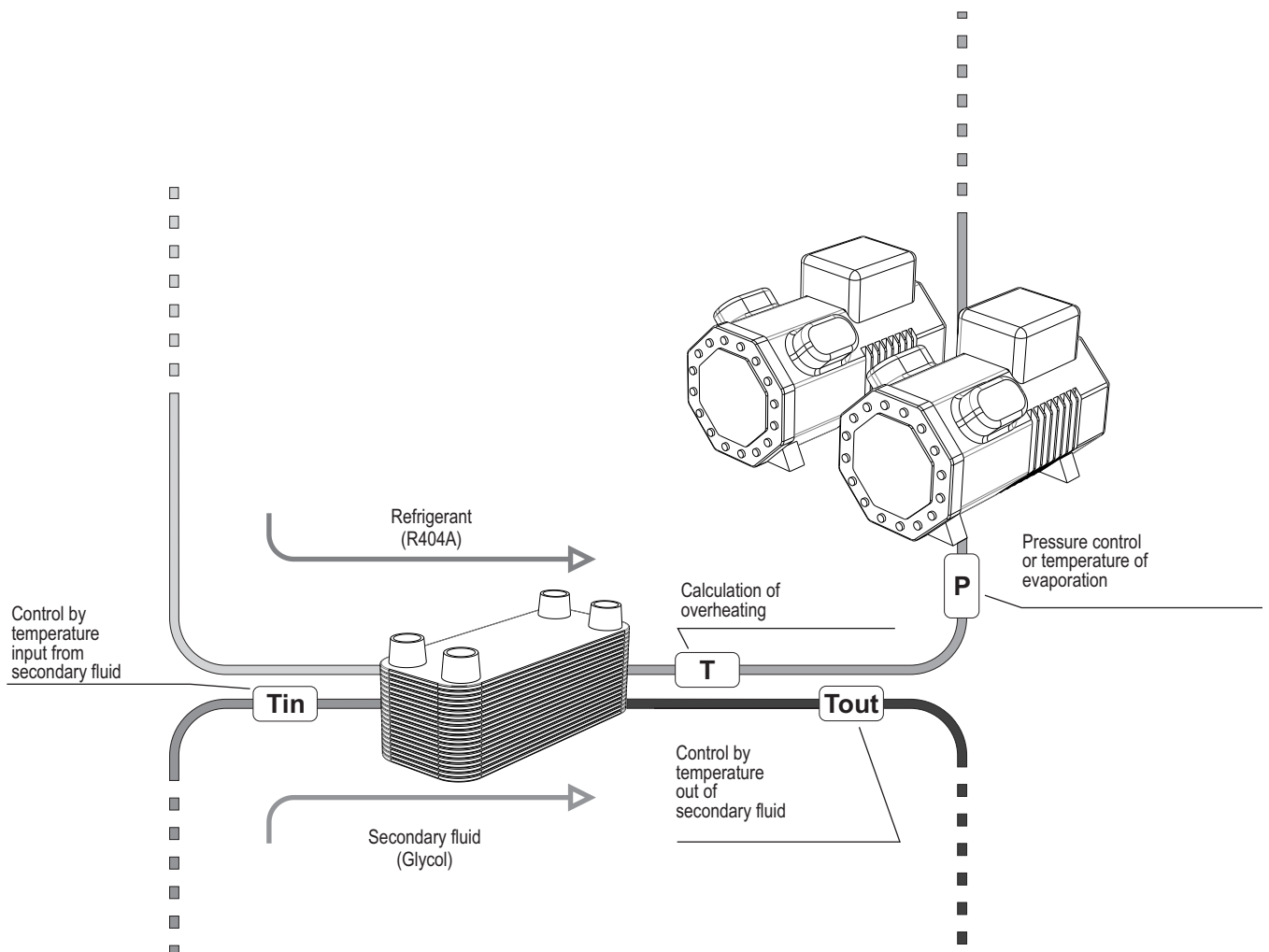

15.SUCTION CONTROLS

15.4.8 Integral action:

In some systems, the control of compressors with only proportional action (Setpoint and hysteresis) tends to present an error in steady state (not reaching the setpoint) or to show oscillatory behavior (excessive pressure variation around the setpoint and high number of compressor start).

In these cases, the use of integral action together with proportional control has the objective of keeping the control pressure stable, converging to values close to the setpoint.

Application example:

Proportional only control

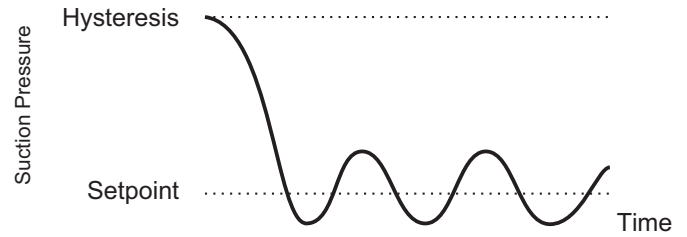
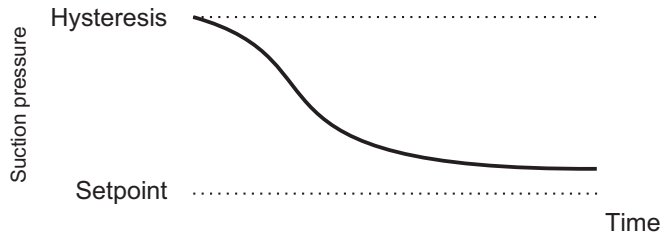

Proportional + Integral Control

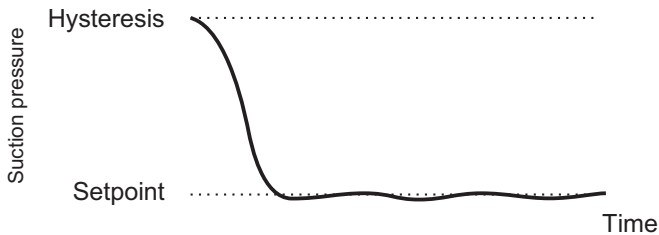

Integral action can be used in all Control Modes, including those that operate only on On/Off outputs. To activate integral action, configure a value other than Off in the Integral time parameter (1 . 2 . x . 21).

The higher the configured value, the slower and more stable the system behavior.

The lower the configured value, the faster and more oscillatory the system behavior.

 **Note:** The definition of this parameter depends on the system's capacity and the response speed of its pressure oscillations. It is recommended to start testing for this parameter with a value of 330 seconds.

15.SUCTION CONTROLS

15.4.9 Low pressure shutdown:

It allows configuring a pressure range where the activated capacity of the line is limited to prevent the system from reaching low pressures during operation. Its use is recommended when the control variable is not the suction pressure..

The shutdown logic operates when the pressure is within the range between "Low Pressure for Shutdown" (1 . 2 . x . 23) and "Critical Pressure for Shutdown" (1 . 2 . x . 22). When the pressure value reaches this range, the activated capacity of the line (number of compressors) is reduced proportionally as the pressure decreases, reaching 0 when the value of Critical Pressure is reached.

Example with On/Off compressors:

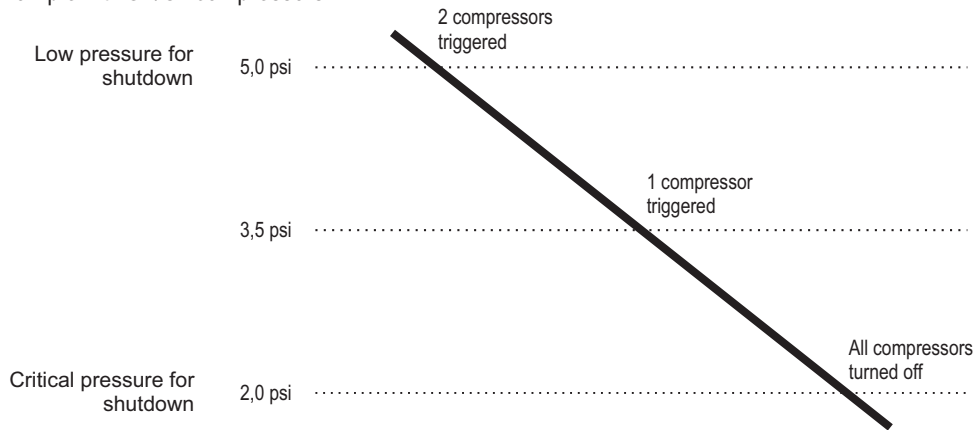

In this example, when the pressure reaches 5.0 psi, 2 compressors are activated. One compressor is turned off at 3.5 psi, which is half of the range, and the other compressor is turned off at 2.0 psi.

Example with VCC compressor:

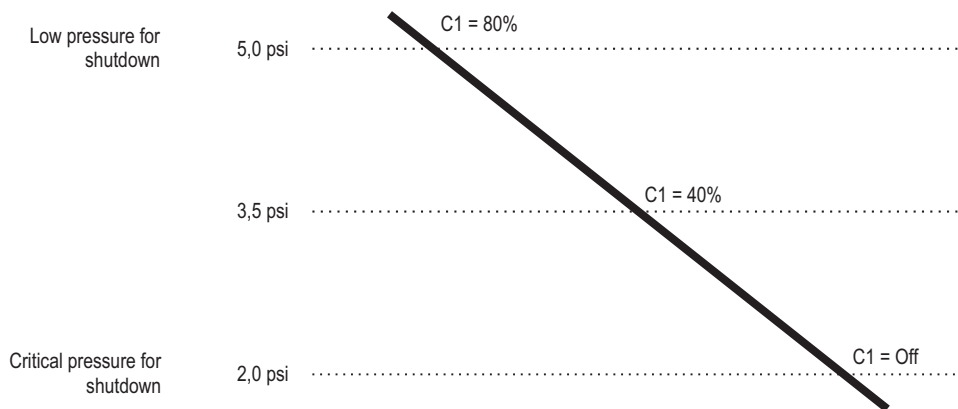

In this example, when the pressure reaches 5.0 psi, the compressor operates at 80% of its capacity. The capacity is reduced proportionally until the compressor is turned off at 2.0 psi

15.SUCTION CONTROLS

15.4.10 Lubrication control:

The circulation of lubricating oil through the refrigeration circuit is ensured by the operation of the compressor. However, during periods of low capacity operation, this circulation is compromised, and there may not be sufficient return of lubricant back to the compressor. To promote oil circulation during periods of low capacity operation, lubrication control functions should be used. The control routine involves making the compressor operate at a capacity above the demanded level for a specified period. If the compressor capacity remains below the value set in "VCC: Capacity to enter Lubrication Control" (1.2.x.94) for the time specified in "VCC: Time to Enter Lubrication Control" (1.2.x.96), the capacity is increased to the value of "Capacity During Lubrication Control" (1.2.x.95) for the time specified in "VCC: Time in Lubrication Control" (1.2.x.97).

If the system behavior changes and requires higher capacity during the lubrication time, increasing the capacity is allowed, but decreasing below the set value is not.

The correct selection of configuration parameters should follow the compressor manufacturer's recommendations and the characteristics of the refrigeration system.

 **Note:** To avoid triggering low-pressure protections during the lubrication routine, it is recommended to use the low-pressure shutdown logic, presented in Chapter 15.4.9.

 **Note:** This routine applies only to compressor 1 of each suction line and only for variable-capacity compressors.

Example:

1.2.1.94	VCC: Capacity to Enter Lubrication Control	= 20%
1.2.1.95	Capacity During Lubrication Control	= 40%
1.2.1.96	VCC: Time to Enter Lubrication Control	= 3600 segundos
1.2.1.97	VCC: Time in Lubrication Control	= 300 segundos

In this example, the capacity of compressor 1 in Suction 1 is increased to 40% if it operates below 20% for a period of one hour, remaining at 40% for 5 minutes.

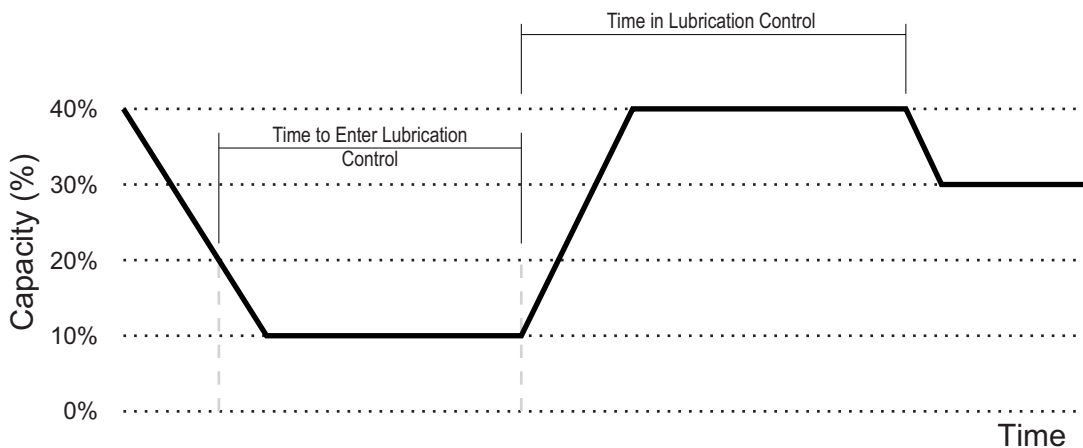

15.SUCTION CONTROLS

15.4.11 Control of capacity variation rate for variable compressors:

The **RCK-862^{plus}** allows for the assignment of ramp rates during the startup, operation, and controlled shutdown of variable compressors. The compressor will only start if the system demand exceeds the value set in "VCC: Minimum Starting Capacity" (1.2.x.86). During startup, the compressor remains in a specific state for the time configured in "VCC: Time at Starting Capacity" (1.2.x.88), with each type of compressor exhibiting specific behavior depending on the modulation type selected in "Compressor 1 Modulation" (1.2.x.38).

VCC-Analog Compressors assume the capacity value set in "VCC: Minimum Starting Capacity" (1.2.x.86).

VCC-Digital Compressors keep the auxiliary outputs energized, causing the compressor to operate without fluid compression.

VCC-25 | 50 | 75 | 100 | S Compressors, screw type with sliding valve, maintain only auxiliary output 3 activated, acting as the Start Unloader (SU).

The functions "VCC: Pre-Shutdown Capacity" (1.2.x.87) and "VCC: Pre-Shutdown Capacity Time" (1.2.x.89) allow the compressor to operate at a certain capacity and for a specified time before shutdown.

When Compressor 1 is selected as VCC-Analog, acceleration ramps can be set for startup and shutdown to ensure the compressor reaches the desired capacity values smoothly.

To set the startup ramp, configure the desired value in "VCC-Analog: Startup Ramp Time" (1.2.x.99). This function determines the time the analog output takes to gradually reach the startup value from 0%.

For the shutdown ramp, configure "VCC-Analog: Shutdown Ramp Time" (1.2.x.100), which is the time the output takes to vary from the pre-shutdown value to 0%.

Additionally, to make capacity variations of the compressor smoother, it is possible to set a capacity variation rate during operation. For this, specify the value for "VCC: Operating Variation Time" (1.2.1.98). This function determines the time interval for varying the compressor's capacity from 0 to 100%. Therefore, the higher the configured value, the slower the capacity variation of the compressor..



Note: This function applies to any type of VCC compressor.



Note: If the start-up ramp, shutdown ramp, and variation time functions are configured with a value of 0, the capacity values calculated by the control are applied instantly to the compressor.

Example:

1.2.1.84	VCC: Minimum Capacity	= 10%
1.2.1.86	VCC: Minimum Starting Capacity	= 30%
1.2.1.87	VCC: Pre-Shutdown Capacity	= 20%
1.2.1.88	VCC: Startup Capacity Time	= 20 seconds
1.2.1.89	VCC: Pre-Shutdown Capacity Time	= 10 seconds
1.2.1.98	VCC: Operating Variation Time	= 60 seconds
1.2.1.99	VCC-Analog: Startup Ramp Time	= 10 seconds
1.2.1.100	VCC-Analog: Shutdown Ramp Time	= 5 seconds

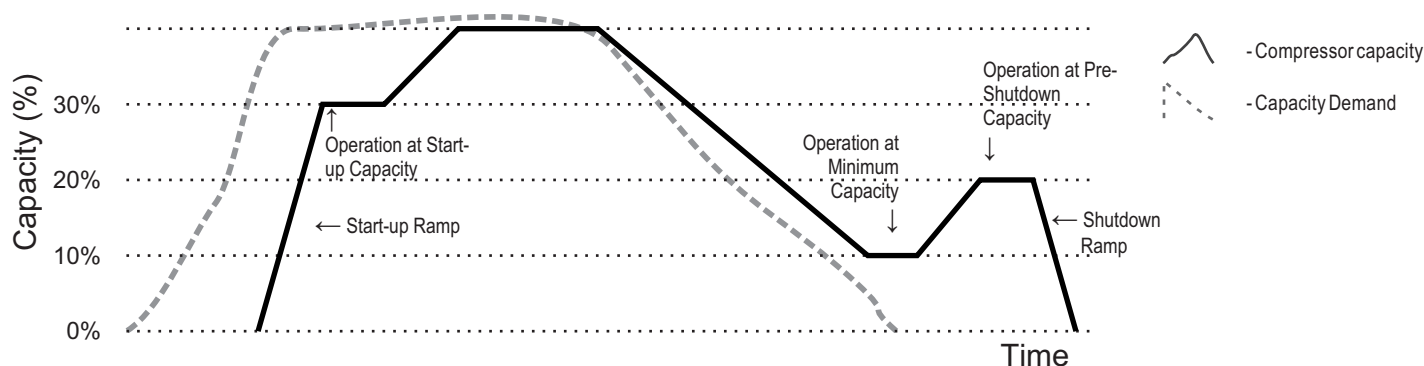

16.DISCHARGE CONTROLS

16.1 Control Modes

The Discharge Control Mode (1.3.x.1) defines the preference for fan activations and deactivations. For discharge control, the **RCK-862 plus** has the following Control Modes: Linear Mode, Rotation Mode, Dead Zone Mode, and Dead Zone with Rotation Mode.

16.2 Types of discharge control

The discharge control can be performed by monitoring either pressure or temperature. The control type is adjusted according to the variable you wish to use in the parameter Control type (1.3.x.2).

Pressure: When the Control Type (1.3.x.2) is set to pressure, the **RCK-862 plus** uses the pressure-related parameters from 1.3.x.3 to 1.3.x.10. In this control mode, a temperature sensor (1.3.x.21) can also be added to monitor the refrigerant fluid's outlet temperature from the condenser (subcooling calculation).

Temperature: When the Control Type (1.3.x.2) is set to temperature, the **RCK-862 plus** uses the temperature-related parameters from 1.3.x.11 to 1.3.x.18.

16.2.1 Linear Mode

16.2.1.1 Linear Mode linked only with digital fan outputs ON/OFF

Linear mode, when it only has digital outputs linked, controls the actuation and shutdown of each fan sequentially and with pressure / temperature intervals of the same magnitude (step).

The **RCK-862 plus** uses a setpoint value and pressure or temperature hysteresis (depending on the type of control) to control the discharge.

Actuation Pressure value of the "N" Output Actuation = Setpoint + (N x Step)

Shutdown Pressure value of the output "N" Actuation = Setpoint + (N-1 x Step)

$$\text{Step} = \frac{\text{Digital hysteresis}}{\text{Number of outputs}}$$

Step for activating the outputs

Pressure value for output "N" actuation
 Activation = Setpoint + (N x Step)

Pressure value for output "N" deactivation
 Actuation = Setpoint + (N-1 x Step)

Example:

1.3.x.1 Control mode: Linear

1.3.x.3 Setpoint: 250 psi

1.3.x.5 Hysteresis of digital outputs: 20

1.3.x.24 Number of fans: 6

1.3.x.25 Fan 1 modulation: without modulation

1.3.x.42 Integral Time: Off

In this case, each fan is associated with a digital output and the step is defined as 60/6 = 10 psi.

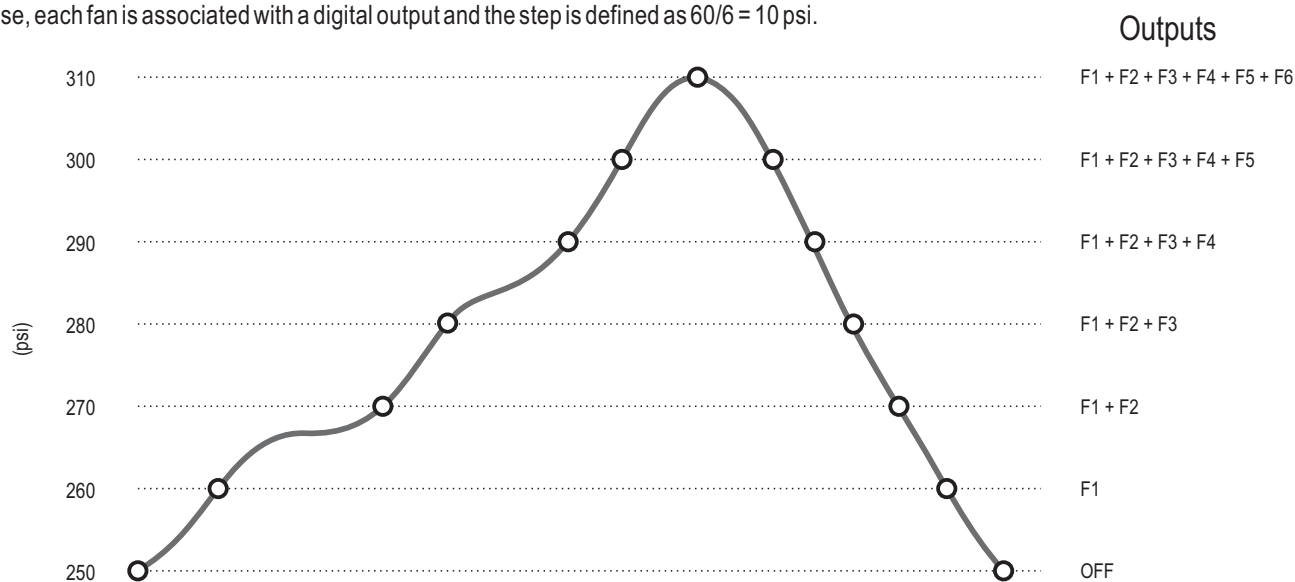

16.2.1.2 Inverter-modulated fan:

The fan control with a frequency inverter uses an analog output (0-10V).

Only Fan 01 of each discharge line can be configured as an inverter. During its operation, the inverter-modulated fan is the first to be activated and the last to be deactivated. Example: In item 1.3.x.25 set the "Fan 01 Modulation" as "Inverter" and select an analog output for the inverter. A digital output can also be selected for the start/stop function by choosing a digital output in the "Fan Digital Output" parameter (1.3.x.30).

You can configure the working output values (minimum, maximum, and startup) in the corresponding functions from 1.3.x.26 to 28.

Integral action can be selected along with proportional control (PI mode) by using the Integral Time parameter (1.3.x.42).

Note: When more than one fan is controlled by only a single proportional output, the number of fans (1.3.x.24) is set to 1 and Compressor Modulation (1.3.x.25) as inverter.

16.DISCHARGE CONTROL

16.2.1.3 Linear mode using a fan (inverter) together with fans linked with digital outputs:

Fan 1 of each discharge can be controlled proportionally and associated with a 0-10V proportional analog output for its control. To do this, the modulation for Fan 1 should be set to inverter and an analog output assigned (1.3.x.29). The use of a start-stop output is optional, and to configure it, select a digital output for the fan in the parameter Fan 1 Digital Output (1.3.x.30).

When the inverter fan operates along with ON | OFF fans, control is managed through a setpoint value and two hysteresis values. The hysteresis of analog output (1.3.x.6) corresponds to the maximum value of the fan analog output, while the hysteresis of the digital outputs (1.3.x.5) applies to all ON | OFF fans.

The inverter fan is the first to be activated and the last to be deactivated. The ON | OFF fans are activated only after the inverter fan reaches 100% of its speed. For each fan activated, the inverter compressor output is reduced to compensate for the added portion. Similarly, when a fan is deactivated, the analog output value increases to compensate for the portion that was reduced.

Example:

1.3.x.1 Control mode: Linear

1.3.x.2 Control type: Pressure

1.3.x.3 Setpoint: 250

1.3.x.5 Hysteresis of digital outputs: 20

1.3.x.6 Analog hysteresis: 10 psi

1.3.x.24 Number of fans: 3

1.3.x.25 Fan 1 modulation: without modulation

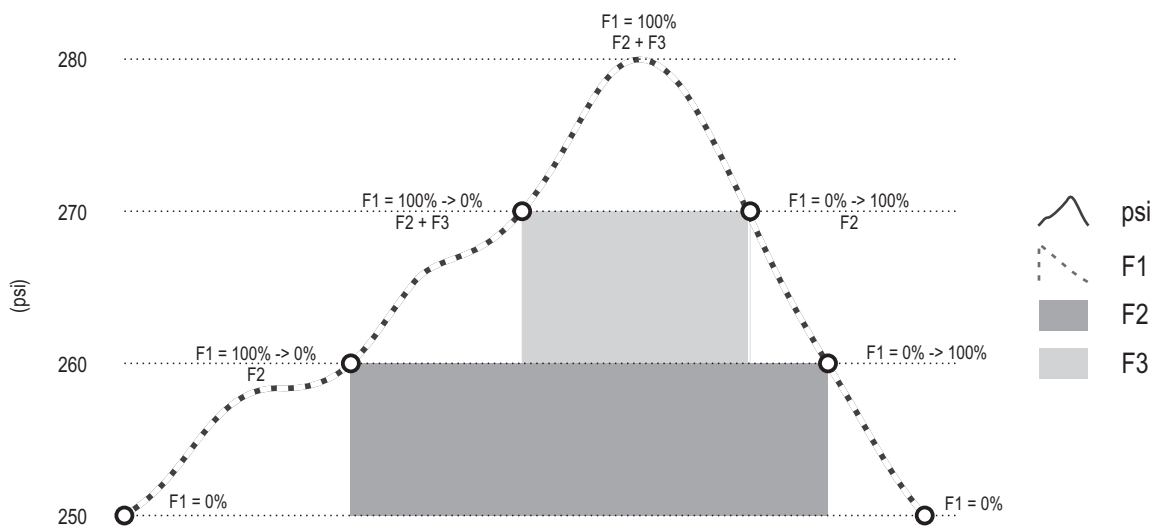

1.3.x.42 Integral time: Off

In this case, each fan is linked with a digital output and the step is defined as $20/2 = 10$ psi.



16.2.2 Rotation:

This mode operates in a similar way to the Linear Mode, however, making an hourly rotation to actuate and shutdown fans according to the record of the entire hours worked by each piece of equipment. When the control recognizes the need to start a fan, the preference will be given for the fan with the lowest number of entire work hours recorded. Likewise, when it is necessary to shut down a fan, the preference will be given to the one with highest number of work hours recorded.

The record of the number of hours worked by each fan is displayed in the control menu, in the Hour meter option. In this same menu it is possible to reset one (select the fan and press ) or all (hold  for 2 seconds) the time records.

As a fan with Inverter modulation it is always the first to actuated and the last to be shut down it does not enter the rotation, that is, the rotation is made only with ON | OFF fans.

16.2.3 Dead Zone:



This Control Mode is used to create a control region around the setpoint without actuating and shutting down the fans. The operation for discharge pressure switches is like that for suction pressure switches.



Note: The use of proportional fans (inverter) is not allowed in this control mode.

16.2.4 Dead Zone + rotation:

This mode operates in a similar way to the Linear Mode, however, making an hourly rotation to actuate and shut down the fans according to the hours worked. When the control recognizes the need to start a fan, the preference will be given for the one with the lowest number of entire work hours recorded. Likewise, when it is necessary to shut down a fan, the preference will be given for the one with the highest number of entire work hours recorded.

The number of hours worked by each fan can be viewed in the control menu, in the Hour meter option. In this same menu it is possible to reset one (select the fan and press ) or all (hold  for 2 seconds) time records.

As a fan with Inverter modulation, it is always the first to be actuated and the last to be shut down, it does not enter the rotation, that is, the rotation is made only with fans without modulation.



Note: The use of proportional fans (inverter) is not allowed in this control mode.

16.DISCHARGE CONTROL

16.2.5 Integral Action:

In some systems the control of fans with only proportional action (Setpoint and hysteresis) tends to present an error in steady state (not reaching the setpoint) or to show oscillatory behavior (excessive pressure variation around the setpoint and high number of fan activations).

In these cases, the use of integral action together with proportional control has the objective of keeping the control pressure stable, converging to values close to the setpoint.

Proportional-only Control

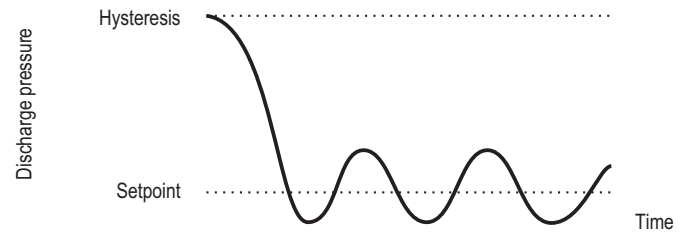
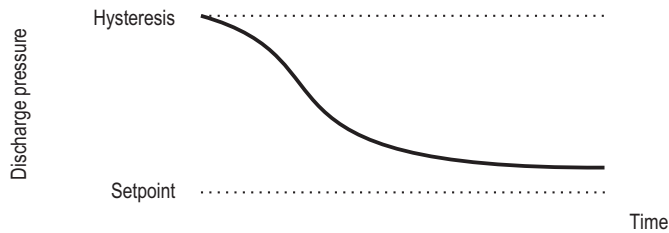

Proportional + Integral Control

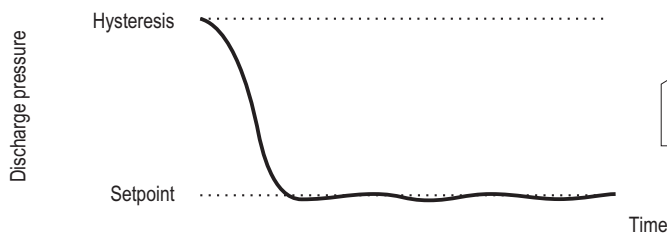

Note: Integral effect reduced the oscillation and brought the system closer to the setpoint.

The integral action can be used in all control modes, including those that operate only on the ON I OFF outputs. To activate the integral action, simply set a value other than Off outputs. To activate the integral action, simply set a value other than Off in the parameter Integral time (1 . 3 . x . 42).

The higher the configured value, the slower and more stable the system's behavior.

The lower the configured value, the faster and more oscillatory the behavior is.



Note: The definition of this parameter depends on the capacity of the system and the response speed of its pressure fluctuations. It is suggested to start the tests to define these parameters using the value of 350 seconds.

17.AUXILIARY FUNCTIONS

The **RCK-862 plus** allows configuring some complementary functions to control the Rack system. The Pump Down and Compressor protection thermostat logic apply to suctions. The logic of adiabatic condensation and dynamic condensation apply to discharges and aims to adjust the Rack to work with less energy consumption. The individual pressure switch logics allow to control up to 3 pressure switches independently from the main control of the Rack.

The individual thermostat logic allows controlling the temperature individually or linked with a suction pressure switch, as well as perform defrost logics based on time.

The logic of rotating outputs allows you to cycle the actuation of outputs based on time. And the Control Status Logic allows to link a digital output to indicate the activate of the control

17.1 Pump down:

Pump Down allows for the shutdown of the Cooling groups with collection of the refrigerant fluid. By activating Pump Down the control switches off the last compressor of each suction at a pressure setpoint lower than the operating pressure setpoint, thus allowing to reduce the amount of cooling fluid stored in the suction lines.

To configure the Pump Down, access menu 1 . 7 . 1 . **RCK-862 plus** allows the Pump Down shutdown to be done manually, for a group of suctions, or automatically, for each suction line.

For manual shutdown, it is recommended to assign a digital output to command a block valve for the group.

For automatic shutdown there are two options: Controlled by the **RCK-862 plus** via a digital output, for commanding a block valve or for signaling an expansion valve controller; or controlled by thermostats, with no digital output assigned, to use with multiple evaporators with multiple evaporators.

During the Pump Down process the low pressure and critical superheat, low and high alarms remain off.

Manual shutdown:

The manual shutdown feature can be used in case of a need to shut down for maintenance or outage for long periods. It must be done via Control Menu - Pump Down or via RS-485. When the command to perform the withdrawal is sent, the group's Pump Down output is activated so that the fluid passage is blocked. The last compressor of each suction line remains in operation until the suction pressure reaches the value set in "Group x: Shutdown pressure" (1 . 7 . 1 . 1 . 1 , 6 or 11) or until the time set in "Group x: Maximum Shutdown Time" (1 . 7 . 1 . 1 . 2 , 7 or 12). The output remains activated until a new command is sent to exit the Pump Down condition.

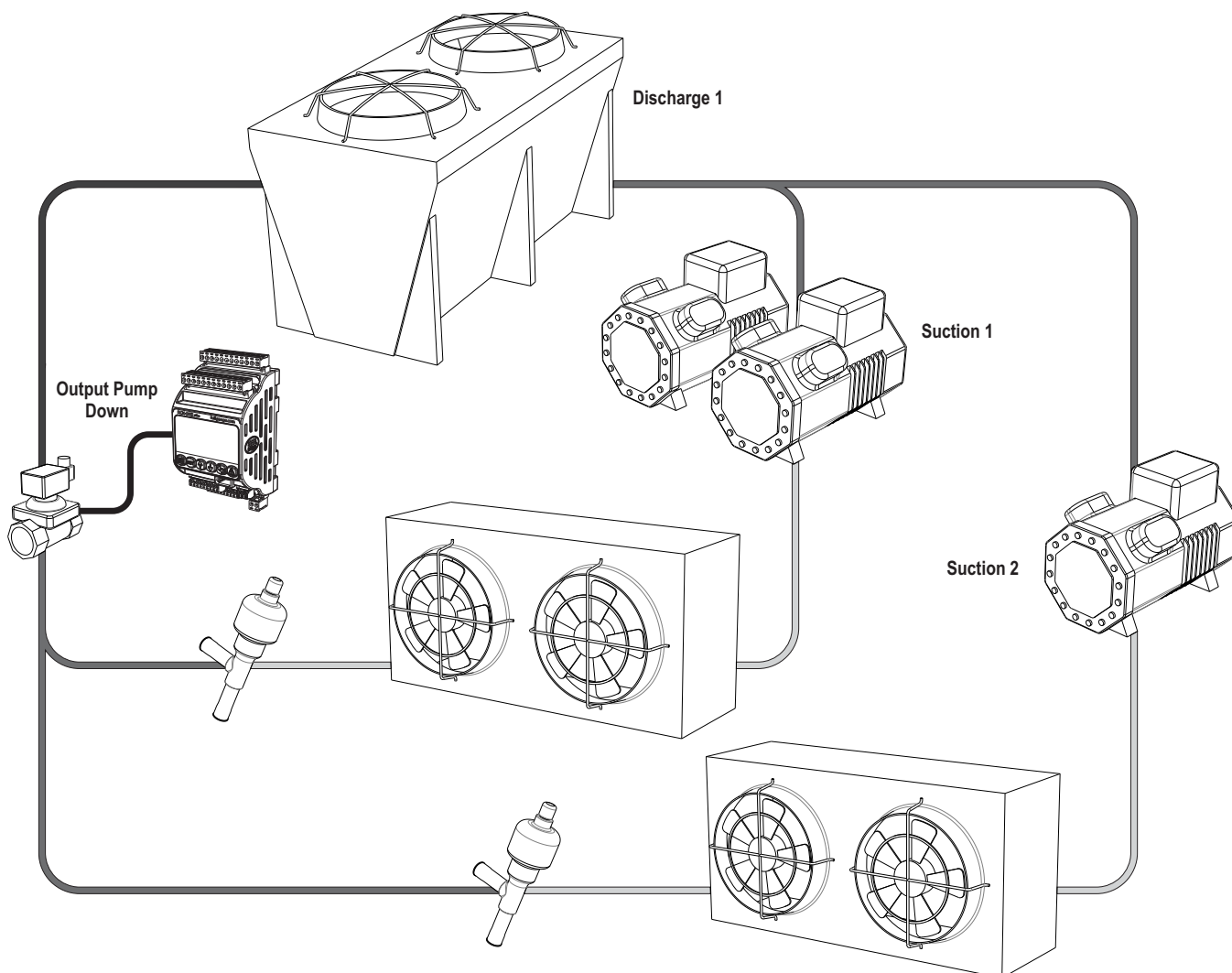

17.AUXILIARY FUNCTIONS

Example:

Group 1 with two suctions and a digital output for activating a Pump Down valve:

Groups:

1.1.2 Number of suction pressure switches: 1

1.1.5 Suction 1 Group : Group 1

Suction 1:

1.2.1.3 Pressure setpoint: 50.0 psi

1.2.1.5 Hysteresis of On/Off compressors: 10 psi

1.2.1.31 Number of compressors: 2

1.2.1.38 Modulation of compressor 1: On/Off

1.2.1.39 Modulation of compressor 2: On/Off

1.2.1.53 Main output of compressor 1: O1

1.2.1.58 Main output of compressor 2: O2

17.1 Pump Down:

1.7.1.1 Group 1: Shutdown pressure: 5.0 psi

1.7.1.2 Group 1: Maximum shutdown time: 30 seconds

1.7.1.3 Group 1: Enables Pump Down: Yes (flow blocking is done by the digital output)

1.7.1.4 Digital output: O4

1.7.1.5 Contact type NO - NC: NC (Output on releases fluid flow)

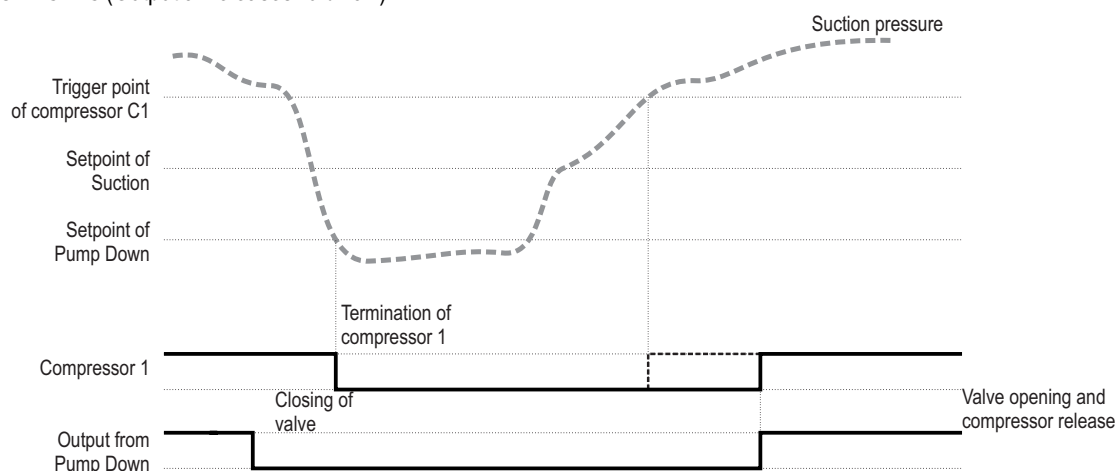

17.2 Automatic shutdown commanded by RCK-862 plus:

If a digital output with fluid collection function is assigned to a suction line (1.7.1.17, 20 or 23) the compressors are switched off with fluid collection.

The **RCK-862 plus** assumes that the pumpout output commands a valve to stop the cooling flow or sends a signal to an external controller for the electronic expansion valve to close. The output is activated when it is necessary to turn off all the compressors, either because the suction line has reached the setpoint or due to a defrost event.

During shutdown, the last active compressor of the suction line is turned off only when the pressure reaches the pressure value for group shutdown (1.7.1.1, 6 or 11) or when the maximum time has elapsed (1.7.1.2, 7 or 12).

17.AUXILIARY FUNCTIONS

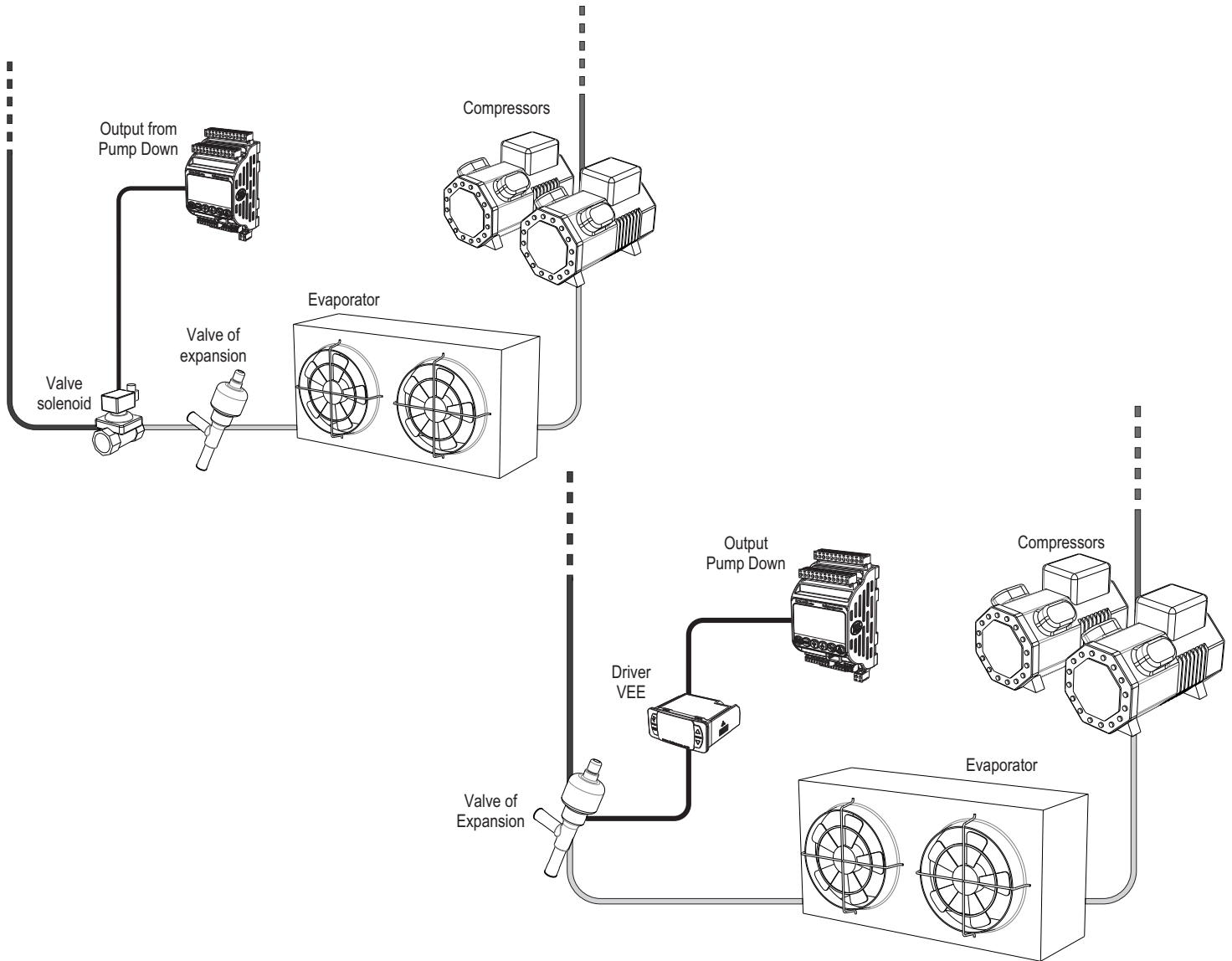

Example:

Suction 1 operating with 2 compressors and a digital output for activating a Pump Down valve:

Groups:

1.1.2 Number of suction pressure switches: 1

1.1.5 Suction 1 Group : Group 1

Suction 1:

1.2.1.3 Pressure setpoint: 50.0 psi

1.2.1.5 Hysteresis of On/Off compressors: 10 psi

1.2.1.31 Number of compressors: 2

1.2.1.38 Modulation of compressor 1: On/Off

1.2.1.39 Modulation of compressor 2: On/Off

1.2.1.53 Main output of compressor 1: O1

1.2.1.58 Main output of compressor 2: O2

Pump Down:

1.7.1.1 Group 1: Shutdown pressure: 5,0 psi

1.7.1.2 Group 1: Maximum shutdown time: 30 seconds

1.7.1.16 Suction 1: Enables Pump Down: Yes (flow blocking is done by the digital output)

1.7.1.17 Suction 1: Digital output: O5

1.7.1.18 Suction 1: Contact type NO - NC: NC (Output on releases fluid flow)

17.AUXILIARY FUNCTIONS

17.3 Automatic shutdown commanded by thermostats:

Automatic shutdown can be done through a link with one or more thermostats. The thermostats are responsible for commanding the start of shutdown and the return of the Pump Down state, releasing the activation of the compressors. A link between an external thermostat (cold room controller) and a suction line is accomplished by configuring an auxiliary input with the Pump Down function in menu 1.6. In this case, the connection between an external controller output and an **RCK-862 plus** input is required. To create a link between an internal thermostat "Individual Thermostat (1.7.6)" and a suction line simply select the suction line in the 1.7.6.x.7 menu.

If none of the linked thermostats have a demand for Cooling, the flow of refrigerant fluid is blocked by the thermostat valves and the **RCK-862 plus** understands that it must perform a shutdown with fluid withdrawal. In this case, the last compressor in the suction line remains active until the value of the shutdown pressure (1.7.1.x.1,6 or 11) or the Maximum Time (1.7.1.x.2,7 or 12) is reached.

If at least one thermostat has a demand for Cooling, the shutdown process is completed and the compressors remain ready to go into operation.

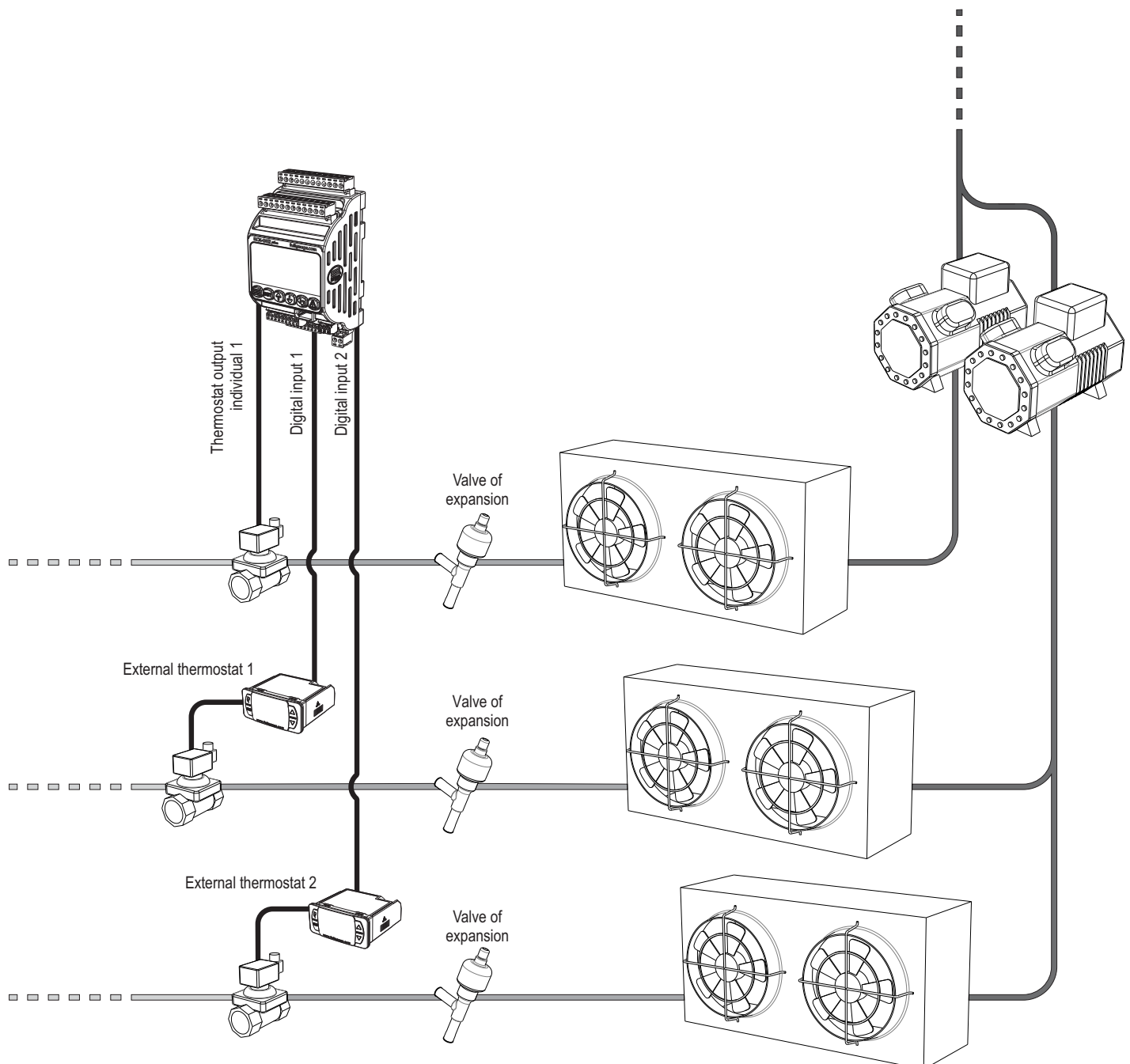

17.AUXILIARY FUNCTIONS

Example:

Suction 1 operating with 2 compressors, 2 External Thermostats and 1 Individual Thermostat:

Suction 1:

- 1.2.1.3 Pressure setpoint: 50.0 psi
- 1.2.1.5 Hysteresis of On/Off compressors: 10 psi
- 1.2.1.31 Number of compressors: 2
- 1.2.1.38 Modulation of compressor 1: On/Off
- 1.2.1.39 Modulation of compressor 2: On/Off
- 1.2.1.53 Main output of compressor 1: O1
- 1.2.1.58 Main output of compressor 2: O2

Pump Down:

- 1.7.1.1 Group 1: Shutdown pressure: 5.0 psi
- 1.7.1.2 Group 1: Maximum shutdown time: 30 seconds
- 1.7.1.3 Group 1: Enables Pump Down: No (the flow blocking is done by the thermostats)
- 1.7.1.16 Suction 1: Enables Pump Down: Yes (flow blocking is done by the digital output)

External thermostats (auxiliary inputs 1 and 2):

Input 1:

- 1.6.1.1 Link of use: Suction 1
- 1.6.1.2 Input function: Activates External Thermostat
- 1.6.1.3 Digital input address: I1
- 1.6.1.4 Contact type NO - NC: NO

Input 2:

- 1.6.2.1 Link of use: Suction
- 1.6.2.2 Input function: Activates External Thermostat
- 1.6.2.3 Digital input address: I2
- 1.6.2.4 Contact type NO - NC: NO

Internal Thermostat (Individual Thermostat 1):

- 1.7.6.1.1 Operation mode: Cooling
- 1.7.6.1.2 Temperature setpoint: 5°C
- 1.7.6.1.9 Control output: O4
- 1.7.6.1.14 Control link: Suction 1

In this example, the Suction 1 control goes into Pump Down process if the digital inputs I1, I2 and the Output O4 is off.

(External thermostats requesting Pump Down and Internal thermostat below setpoint).

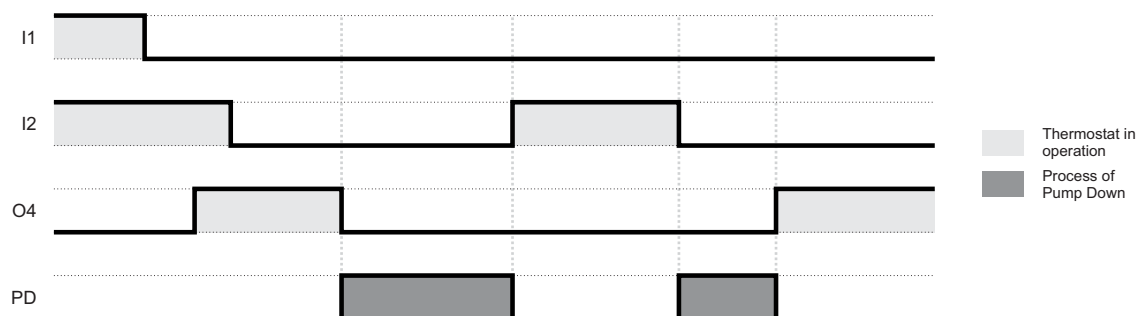

After the last compressor is turned off, the activation of the compressors remains blocked until one of the thermostats has a demand for refrigeration. (Inputs I1 or I2 off or output O4 on).

17.FUNÇÕES AUXILIARES

17.4 Pump control:

The **RCK-862_{plus}** plus allows for the use of up to 3 pump groups, with each group capable of configuring up to three pumps operating in rotation. Pumps 2 and 3 have an Operation Mode configuration (1.7.7.x.7 e 1.7.7.x.8) that can be set to either Rotation or Standby. A pump configured as Standby only activates when a rotating pump is turned off due to an alarm or is undergoing maintenance. The first pump to be activated is always the one with the fewest operating hours. Each group has a Control Link configuration (1.7.7.x.9) where the controller is informed of which suction or suction group the pump set is operating in. Based on this configuration, the compressors of the linked suction only operate after the Compressor Start Time after pump activation (1.7.7.x.3) has elapsed and are turned off if all pumps are off or in maintenance. Additionally, the pumps are turned off if Turn Off Pumps after Suction Shutdown (1.7.7.x.10) is selected and after the Pump Shutdown Time after Suction Shutdown (1.7.7.x.11) has elapsed.

Pump circuit protection is achieved using the controller's digital inputs. Sensors can be installed to indicate the presence and absence of flow in the secondary fluid line. To configure a digital input for flow loss, set the Use Link (1.6.x.1) to 14, 15, or 16 for pump sets 1, 2, or 3, respectively, and set the Input Function (1.6.x.2) to Pump 1 Flow (35) for the flow sensor of pump 1, Pump 2 Flow (36) for the flow sensor of pump 2, Pump 3 Flow (37) for the flow sensor of pump 3, or Pumps Flow (38) for a common flow sensor for all three pumps.

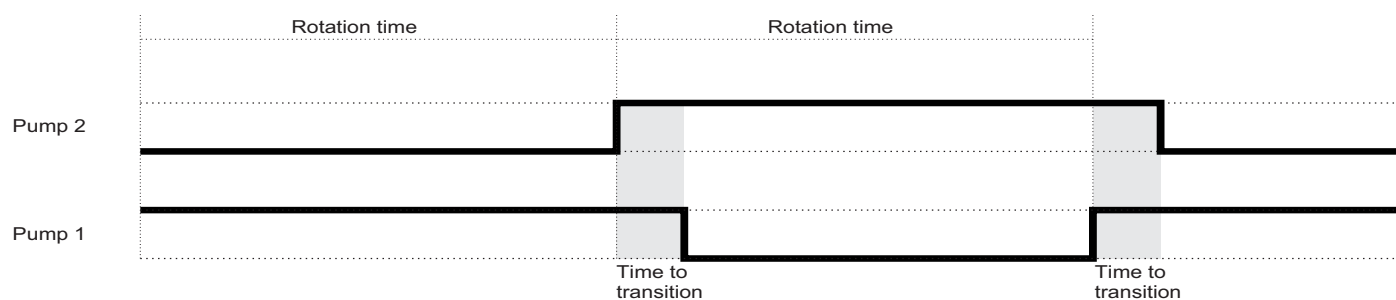

Example: Pump control for a cooled water circuit by suction 1 and flow sensor installed in cooled water line.

Pump control:

- 1.7.7.1.1 Time to rotate = 720 min
- 1.7.7.1.2 Transition time between pumps = 5 seconds
- 1.7.7.1.3 Compressor Start Time after Pump Activation = 20 seconds
- 1.7.7.1.4 Digital output of pump 1 = O4
- 1.7.7.1.5 Digital output of pump 2 = O5
- 1.7.7.1.6 Digital output of pump 3 = O6
- 1.7.7.1.7 Operation mode of pump 2 = Rotation
- 1.7.7.1.8 Operation mode of pump 3 = Reserve
- 1.7.7.1.9 Control Link = Suction 1

Auxiliary inputs:

- 1.6.1.1 Input 1: Link of use = Control of pumps 1
- 1.6.1.2 Input 1: Input Function = Pump flow
- 1.6.1.3 Input 1: Digital input = I5
- 1.6.1.4 Input 1: Contact type NO - NC = NO (Input triggered indicates lack of flow)

Alarms:

- 1.4.1.3 Time to validate other alarms = 5 seconds

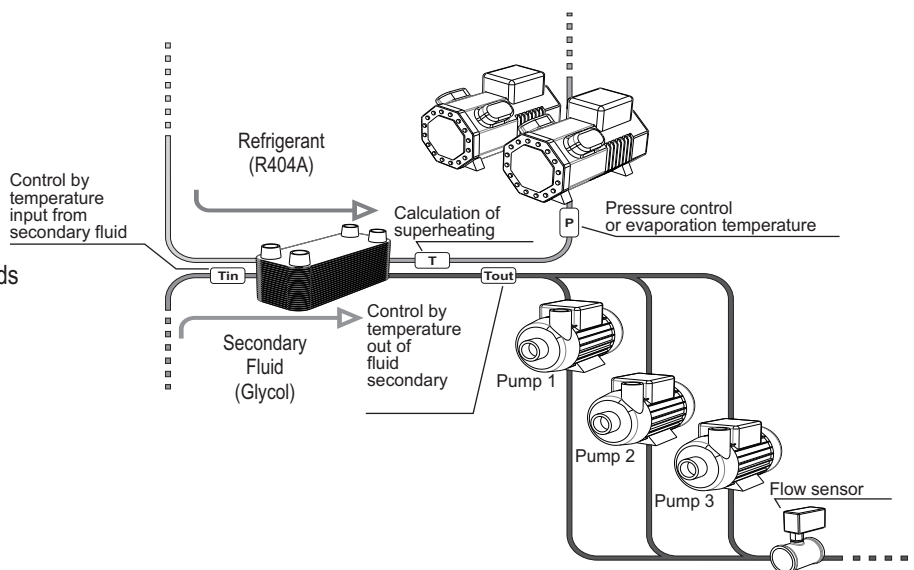

17.AUXILIARY FUNCTIONS

In this example, the first suction compressor 1 is only activated 20 seconds after the start of the first pump and the pumps are rotated every 720 minutes. The function of the digital input is to signal that the secondary fluid flow has been interrupted. If this input is triggered, the operating pump goes into alarm, and the standby pump is activated. If the flow remains interrupted, the standby pump also goes into alarm, and the last pump is engaged. In the event that all three pumps enter alarm, the compressors in suction line 1 are shut down to prevent freezing of the secondary fluid line. Outputs alarms respect the rearming logic defined in the menu 1.4.4.

Example 1: Flow Returns After Activating the Backup Pump

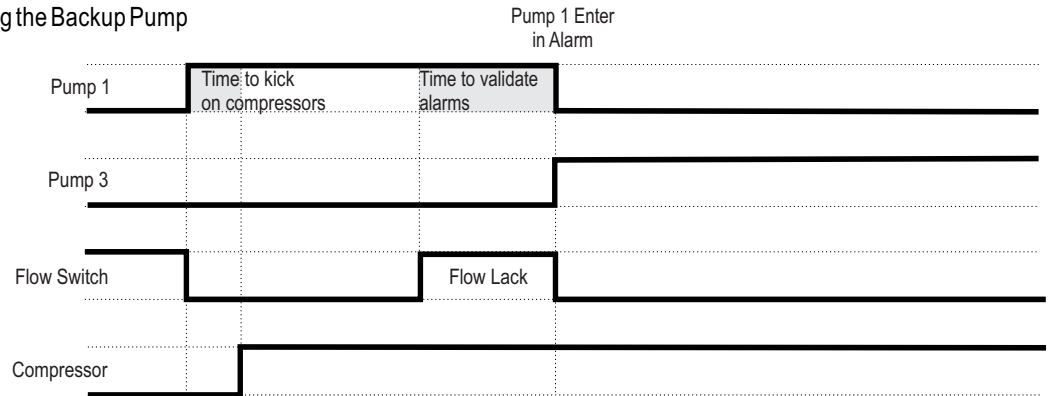

Example 2: Flow Does Not Return

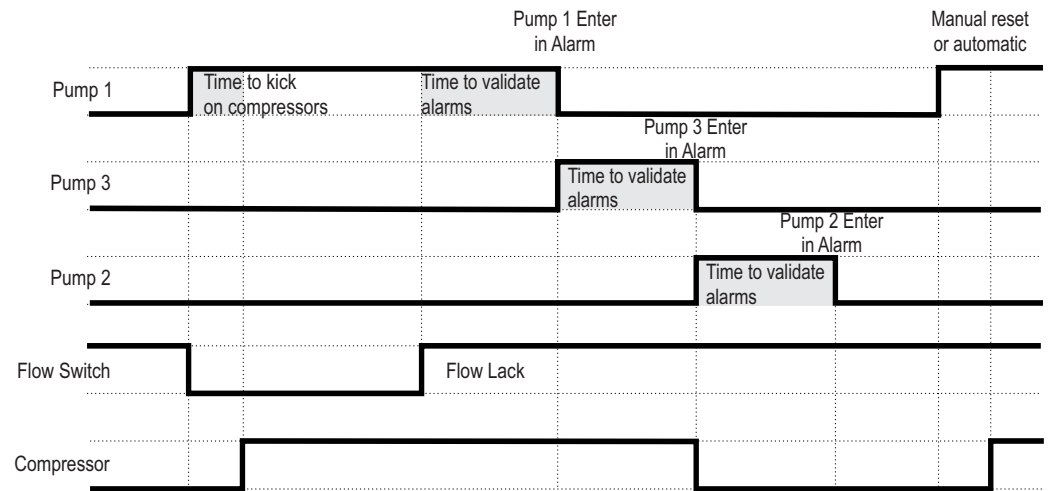

17.5 Defrost for suction lines:

By stopping the compressor controlled through suction lines directly **RCK-862 plus**, either manually, via menu or RS-485, by time or defrost schedule.

Compressors are switched off, respecting the compressor on and off times, or with fluid collection, if enabled in menu 1.7.1. The defrost time is counted after switching off the last compressor.

17.5.1 Defrost by time:

When 1.7.9.x.1 is configured as "Time" the functions "Interval between defrosts" (1.7.9.x.2) and "Defrost time" (1.7.9.x.9) are considered. In this way, the suction line goes into defrost after the interval has elapsed. The interval between defrosts is considered after the end of the last defrost.

17.5.2 Defrost by schedule:

You can configure the defrosting schedule to be equally distributed across the day by programming the number of defrost cycles per day. For this, it is necessary to configure the defrost start as "Schedule" (1.7.9.x.1), and through functions 1.7.9.x.3 to 1.7.9.x.8 configure the amount of defrosts per day and its starting time. With this, the defrost schedule makes it possible to create a schedule from Monday to Friday, another schedule for Saturday and another for Sunday. For Example: If for the schedule from Monday to Friday, the preferred time is set to 1:00 pm and the number of defrosts is set to 4 (6-hour interval), the defrost will be carried out at 01:00 AM, at 07:00 AM, at 01:00 PM and 07:00 PM on the same day.

MONDAY TO FRIDAY

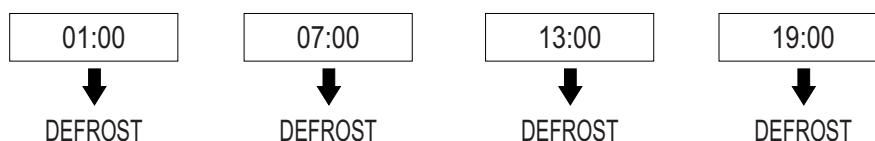

17.AUXILIARY FUNCTIONS

17.6 Compressor protection thermostats:

A protection thermostat can be configured for each of the 6 compressors on the 3 suction lines. Each thermostat has a sensor for measuring the compressor temperature, a digital output for activating a cooling device and a shutdown alarm. The output is activated, and the high temperature alarm only occurs when the compressor is on.

The output is activated if the sensor temperature is higher than the control temperature value (1.7.2.x.1) + hysteresis (1.7.2.x.3) and the output is switched off if the temperature value is lower than the value is lower than the value of the control temperature.

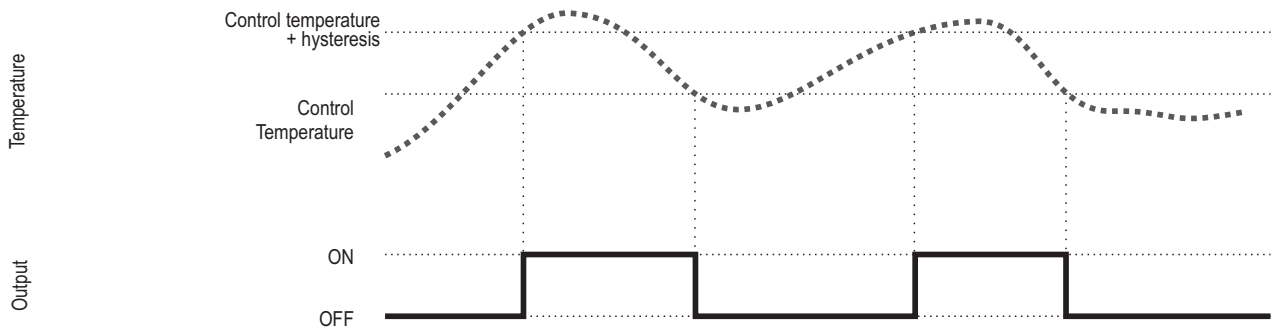

In the Compressor protection thermostats function, a maximum temperature for compressor operation can be defined. If the compressor temperature exceeds the value of Compressor shutdown temperature (1.7.2.x.2), the compressor will shut down and an alarm event will be created. The compressor returns to operation when the thermostat temperature sensor is below the shutdown temperature minus hysteresis.

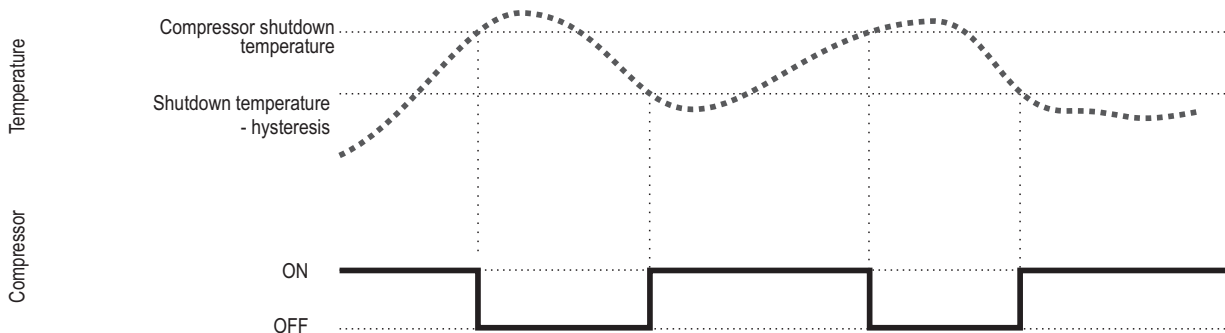

17.7 Adiabatic condensation:

Using the adiabatic condensation logic, it is possible to reduce the temperature of the external air in contact with the condenser and, consequently, reduce the operating pressure of the discharge. The control of adiabatic condensation activates a water pump or a valve that feeds the water curtain through which the external air passes before reaching the condenser. The activation of the output is done by temperature control, using one or two sensors, or exclusively by time acting by means of a cycle timer (time on and time off). The Adiabatic Condensation logic can be enabled to operate only during specific hours using the time parameters Start Time (1.7.3.1.14) and End Time (1.7.3.1.15). Otherwise, its operation is continuous.

17.7.1 Temperature control:

In the Temperature control mode, a sensor must be installed to measure the temperature of the external air (dry bulb sensor) and optionally another sensor to measure the air temperature after passing through the water curtain (wet bulb sensor). The Control Mode (1.7.3.x.1) can be configured as Temperature with a cycle timer and in this case the output cycles between on and off instead of remaining on, whenever the temperature activation condition presents the activation condition. The cycle period must be configured in the parameters Time on (1.7.3.x.12) and Time off (1.7.3.x.13).

If the parameters Temperature for actuation and / or Temperature for shutdown are set to OFF, the control is performed only by differential, using the two sensors.

If the parameters Differential for actuation and / or Differential for shutdown are set to OFF, the control is performed only by temperature, using only the dry bulb sensor.

If the Control Mode (1.7.3.x.1) is configured as Temperature with a cycle timer, the output will be cycling instead of being permanently activated, whenever the temperature activation condition presents the activation condition.

The cycle period must be configured in the parameters Time on (1.7.3.x.12) and Time off (1.7.3.x.13).

17.AUXILIARY FUNCTIONS

17.7.1.1 Temperature control using two sensors (Differential TBS-TBU)

The control output is activated whenever the differential between the readings of the two sensors is lower than the Activation differential (1.7.3.x.4) and is shut off when the differential exceeds the Shutdown Differential (1.7.3.x.5). In this case it is necessary to use two sensors, one for dry bulb temperature (1.3.x.9) and the other for wet bulb temperature (1.7.3.x.10). Temperature differential control is only enabled when the external temperature (TBS) is higher than the value configured in the parameter Minimum Operating Temperature (1.7.3.x.6). If the shutdown differential is not reached within the time interval configured in Differential validation time (1.7.3.x.7) the output will be switched off and will remain blocked until the time for the next attempt has elapsed (1.7.3.x.8). For the control to be carried out using the two sensors, the parameters Temperature for activation (1.7.3.x.2) and Temperature for shutdown (1.7.3.x.3) must be set to OFF.

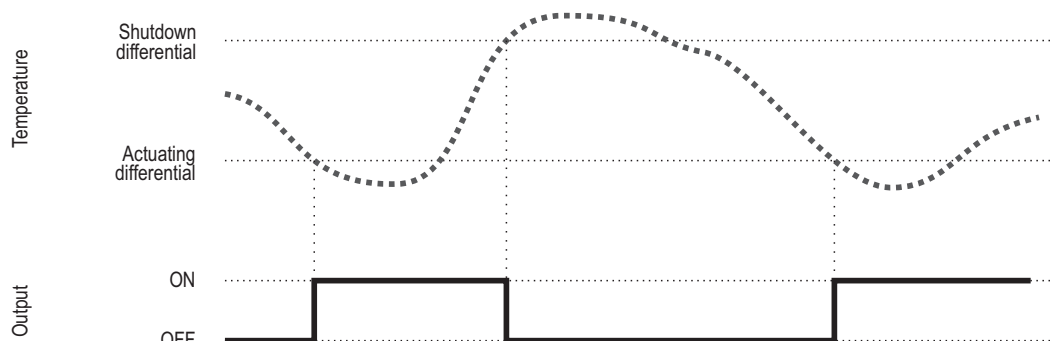

17.7.1.2 Temperature control using a sensor (TBS)

In this mode, only a temperature sensor is used to measure the air temperature in the environment where the condenser is located. If the Temperature value for activation (1.7.3.x.2) is reached, the control output is activated until it returns to the Temperature for shutdown (1.7.3.x.3).

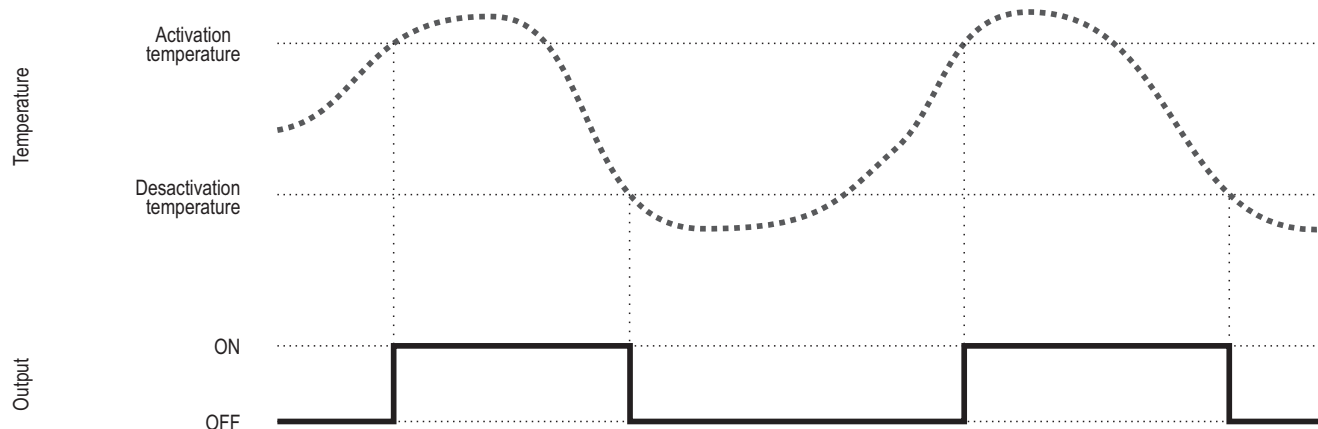

17.7.1.3 Temperature control using two sensors (TBS-TBU Differential and Temperature Limit)

When the four parameters: Temperature for activation (1.7.3.x.2), Temperature for shutdown (1.7.3.x.3), Differential for activation (1.7.3.x.4) and Differential for shutdown (1.7.3.x.5), the control is done by both modes (temperature differential and temperature limits). Whenever at least one of the two modes have an actuation condition, the **RCK-862 plus** activates the control output of the adiabatic condensation. In this case, the output will be activated when the temperature of the dry bulb sensor exceeds the Temperature for activation and will be shut down when the temperature is lower than the Temperature for shutdown; or the output will be actuated when the differential is less than the Differential for activation and will be shut down when the differential is greater than the Differential for shut down.

17.7.1.4 Cycle timer mode:

The control of adiabatic condensation is performed exclusively by cycling the Time On (1.7.3.x.12) and the Time Off (1.7.3.x.13). The digital output (1.7.3.x.11) linked with the water control switches its operation from on to off according to the time parameters. In this case, it is suggested to limit the period of operation of the adiabatic condensation by the parameters Start Time (1.7.3.1.14) and End Time (1.7.3.1.15).

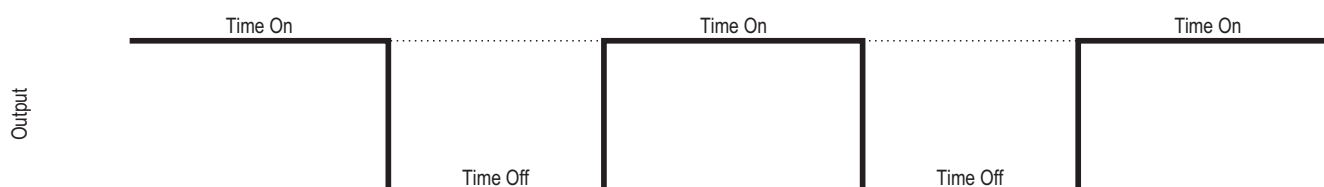

17.AUXILIARY FUNCTIONS

17.8 Dynamic condensation:

Dynamic condensation logic can be used to lower the compressor discharge pressure and consequently reduce the compressor's energy consumption based on the external air temperature.

To use this logic, you need to have a pressure sensor for the discharge, a temperature sensor for measuring the external temperature, and a temperature sensor for calculating the subcooling.

In the Dynamic Condensation menu (1.7.4) you can access essential parameters for the logic, such as the Start Floating Temperature (1.7.4.x.1), the Minimum Setpoint Value (1.7.4.x.2), and value of Low Subcooling for Logic Disable (1.7.4.x.3).

This logic can be programmed to operate only within a time range, according to Start Time (1.7.4.x.5) and End Time (1.7.4.x.6).

When enabled, the logic operates as soon as the temperature from the sensor measuring the external temperature (1.7.4.x.4) is lower than the value set in the Fluctuation Start Temperature (1.7.4.x.1). In this case, the discharge setpoint decreases proportionally as the external temperature decreases, following a 1:1 ratio up to the maximum allowable variation, that is, until reaching the Minimum Setpoint Value configured in (1.7.4.x.2). The controller uses the saturation data of the refrigerant fluid configured for the group belonging to the discharge pressure switch to convert pressure to temperature.

During the floating process, if the calculated subcooling is equal to or less than the value of Low Subcooling for Logic Disable (1.7.4.x.3), the control limits the reduction of the discharge setpoint to the current value. If the subcooling value increases by 1°C, then the dynamic condensation control resumes reducing the discharge setpoint.

If at any point the subcooling decreases to the low subcooling alarm value configured for the discharge line, the logic is disabled and the discharge setpoint returns to its original value.

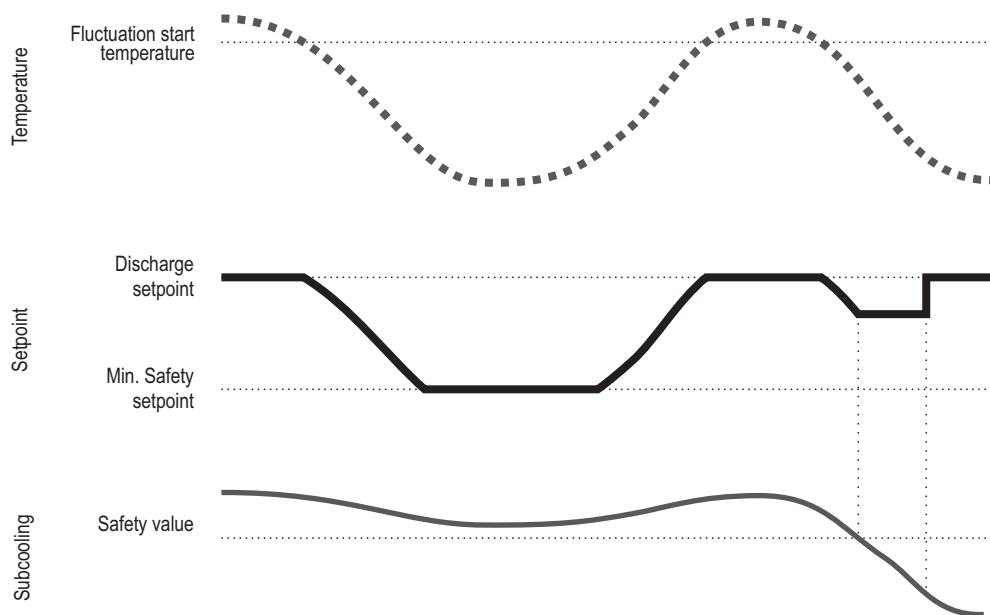

17.9 Individual Pressostat:

The **RCK-862 plus** allows configuring up to 3 individual pressure switches disconnected from the Rack's main control. On each pressure switch, it is possible to associate a pressure sensor and up to 6 digital outputs with setpoint and independent hysteresis.

Each pressure switch can be configured to work in compression or decompression mode. In compression mode, the output is activated if the pressure value is lower than the (setpoint-hysteresis) and shuts off if the pressure value is higher than the setpoint. In the decompression mode, the output is activated if the pressure value is greater than (setpoint+hysteresis) and shuts off if the pressure value is lower than the setpoint.

Example:

- 1.7.5.x Individual pressure switch 1: with two outlets
- 1.7.5.x.1 Operating mode: Decompression
- 1.7.5.x.2 Pressure setpoint 1: 10,0 PSI
- 1.7.5.x.3 Pressure setpoint 2: 20,0 PSI
- 1.7.5.x.8 Pressure hysteresis 1: 5,0 PSI

- 1.7.5.x.9 Pressure hysteresis: 5,0 PSI
- 1.7.5.x.14 Pressure sensor: S1
- 1.7.5.x.15 Digital output address 1: O1
- 1.7.5.x.16 Digital output address 2: O2

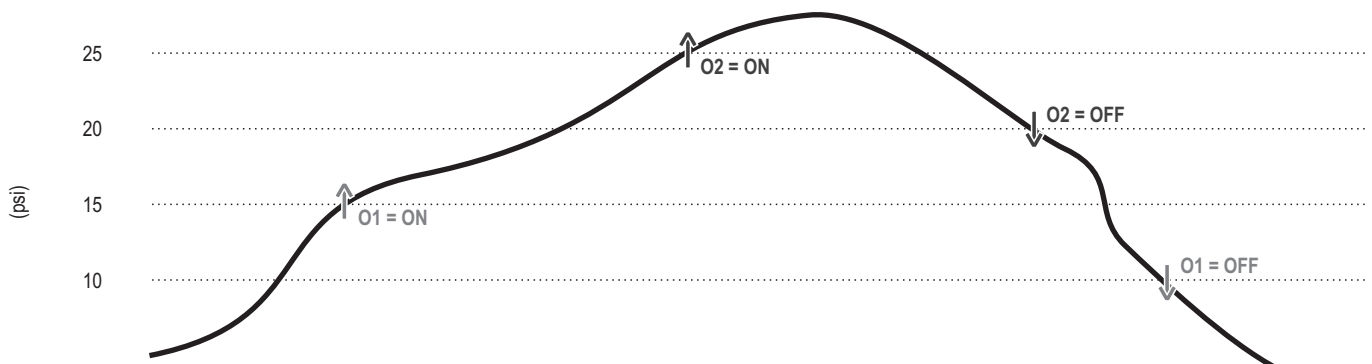

17.AUXILIARY FUNCTIONS

17.10 Individual Thermostat:

The **RCK-862 plus** allows for the configuration of up to 6 thermostats for controlling the temperature of auxiliary circuits. Each thermostat can be configured to operate in either heating or cooling mode. In heating mode, the output is activated if the temperature value is below (setpoint - hysteresis) and deactivates if the temperature value is above the setpoint. In cooling mode, the output is activated if the temperature value is above (setpoint + hysteresis) and deactivates if the temperature value is below the setpoint.

Each thermostat has a Control Link option (1.7.6.x.14) that allows it to be associated with a specific suction line. When a linkage is established, the thermostat operates as a master, enabling control of the suction line during the cooling process. Thus, the suction line is turned off during defrost periods or manual shutdown of the thermostat. If more than one thermostat is linked to the same suction line, only one needs to be in the cooling process for the suction line to be enabled. To turn off the suction line, all linked thermostats must be either off or in defrost.

Each thermostat features a defrost function, which allows setting a fixed interval between defrosts or selecting up to 6 independent times for the start of defrost. Additionally, defrost can be started or ended manually via the control menu or communication protocol.

Defrost can be manually initiated even if the thermostat control is off; in this case, the defrost output remains on for defrost length (1.7.6.x.23) or until the evaporator sensor temperature (1.7.6.x.8) exceeds the Defrost End Temperature (1.7.6.x.21).

Once started, the defrost process follows the sequence below.

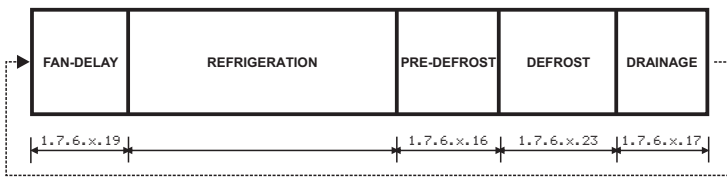

Defrost Stages			
Stage	Compressor	Fan	Defrost Output
Fan delay	●	○	○
Refrigeration	●	●	○
Pre-Defrost	○	●	○
Defrost	○	○	●
Drainage	○	○	○

Key:
 ● - Output on
 ○ - Output off

In specific controls, it is beneficial for the evaporator fan to be operational before starting the compressors to raise the suction temperature and prevent liquid slugging in the compressors. This function can be enabled using the Interlock Time (1.7.6.x.15). In this case, when the refrigeration process begins, the fan will start before the first compressor of the suction line is activated for the time configured in this function, and the compressor will not be activated during the Fan Delay stage. It is recommended that when using the Interlock Time function, the Fan Return Temperature After Draining (1.7.6.x.18) be set to 0.

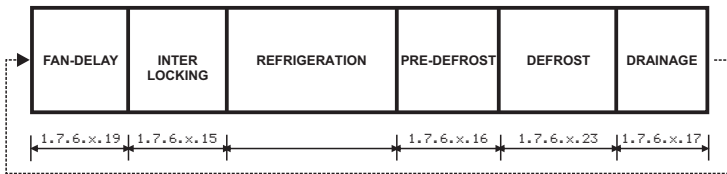

Defrost Stages			
Stage	Compressor	Fan	Defrost Output
Fan delay	○	○	○
Interlocking	○	●	○
Refrigeration	●	●	○
Pre-Defrost	○	●	○
Defrost	○	○	●
Drainage	○	○	○

Key:
 ● - Output on
 ○ - Output off

17.11 Control Status:

Allows for configuring a digital output to indicate the operation status of the controller. This output is only turned off in the event of a power failure and when the control functions are turned off (Control Menu → Control Status = Off).

17.AUXILIARY FUNCTIONS

17.12 Economizer:

Certain compressor models feature an economizer function, which, when activated, increases the compressor's efficiency by enhancing its operating capacity.

The **RCK-862 plus** includes three sets of functions for activating an economizer system for compressors, each set assigned to Compressor 1 of each suction group, respectively. The economizer system is enabled through a digital output, which is activated if the operational rules are met. To delay the activation of the economizer and ensure that the refrigeration circuit is in a determined operational regime, the output can only be activated after the "Activation Delay" (1.7.11.x.2), has elapsed from the compressor start and after the refrigeration system's evaporation temperature has reached the "Minimum Evaporation Temperature" (1.7.11.x.5). Additionally, the economizer system is only activated after the compressor reaches an operational capacity equal to the value set in "Minimum Capacity for Activation" (1.7.11.x.3) and is deactivated if the compressor's capacity decreases to the value set in "Minimum Capacity for Deactivation" (1.7.11.x.4).

To prevent high pressures in the discharge circuit, safety parameters for deactivating the economizer can be configured. Thus, the output is turned off if the discharge circuit's condensation temperature reaches the "Maximum Condensation Temperature" (1.7.11.x.6), and it will reactivate when the temperature falls below this value minus the "Condensation Temperature Hysteresis" (1.7.11.x.7).

To ensure that the compressor operates within the limits specified by the manufacturer, safety parameters for economizer activation can be set. Therefore, the output can only be activated if the compressor discharge temperature is above the value set in "Minimum Discharge Temperature" (1.7.11.x.8).

During operation, the output is turned off if the discharge temperature reaches this minimum value and will reactivate when the temperature rises above this value plus the "Discharge Temperature Hysteresis" (1.7.11.x.9).

- 1.7.11.1.1 Enables economizer = Yes
- 1.7.11.1.2 Activation delay = 300 seconds
- 1.7.11.1.3 Minimum activation capacity = 75%
- 1.7.11.1.4 Minimum deactivation capacity = 25%
- 1.7.11.1.5 Minimum evaporation temperature = -20°C
- 1.7.11.1.6 Maximum condensation temperature = 40°C
- 1.7.11.1.7 Condensation temperature hysteresis = 5°C
- 1.7.11.1.8 Minimum discharge temperature = 60°C
- 1.7.11.1.9 Discharge temperature hysteresis = 10°C
- 1.7.11.1.11 Contact activation type = NO

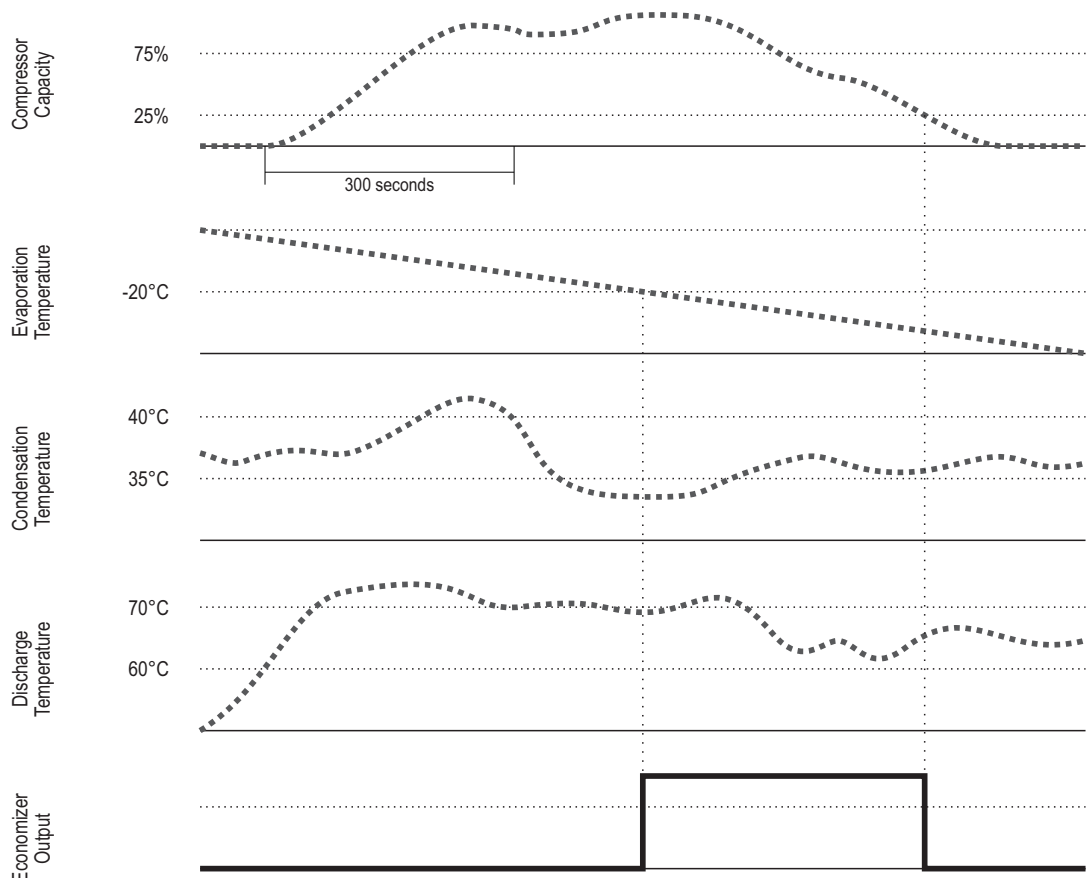

Note: The **RCK-862 plus** is responsible for only enabling the economizer system. An additional controller is required for controlling the circuit's superheating.

17.AUXILIARY FUNCTIONS

17.13 Antifreeze:

The **RCK-862 plus** provides the capability for up to 6 anti-freeze protection groups for secondary fluid. These groups must be connected to the suction lines to ensure that protection is directed specifically to the compressors when a freezing risk condition is identified. To establish this communication between the anti-freeze protection and one or more suction lines, the desired link must be selected in the function "Control Link" (1.7.10.x.12).

Each group is designated to protect a specific heat exchanger. Therefore, in applications with parallel heat exchangers, all groups must be linked to the same suction line. In this way, the compressors in that line will be shut down if at least one of the groups detects a freezing risk condition. In other words, if the temperature of the Control Temperature Sensor (1.7.10.x.8) is below the value configured in Compressor Shutdown Temperature (1.7.10.x.3).

In addition to shutting down the compressors, the anti-freeze protection includes alarms for low and high temperature differential between inlet and outlet to indicate potential issues in the secondary fluid line and a digital output for activating an auxiliary protection circuit.

The low and high differential alarms are enabled only if the Control Temperature (1.7.10.x.8) is below the value configured in Minimum Antifreeze Alarm Temperature (1.7.10.x.1). The Control Output (1.7.10.x.11) is activated if the temperature drops below the Control Output Activation Temperature (1.7.10.x.2).

The Antifreeze logic has configuration for up to 3 temperature sensors. The first is the Control Output (1.7.10.x.11), used for activating the control output and shutting down the compressors, which may be the same as the inlet or outlet sensor or a third sensor positioned at another point of interest. The Outlet (1.7.10.x.10) and Inlet (1.7.10.x.9) sensors are used only for monitoring.

If the control output is active when the compressor shutdown temperature is reached, it will deactivate after the low-temperature alarm ends.

Low Differential Alarm:

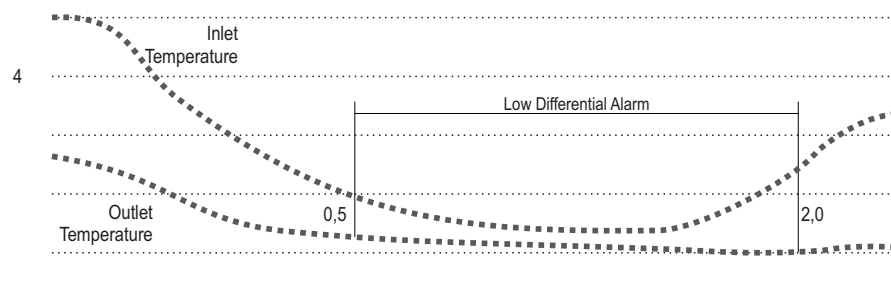

Activation of Control Output:

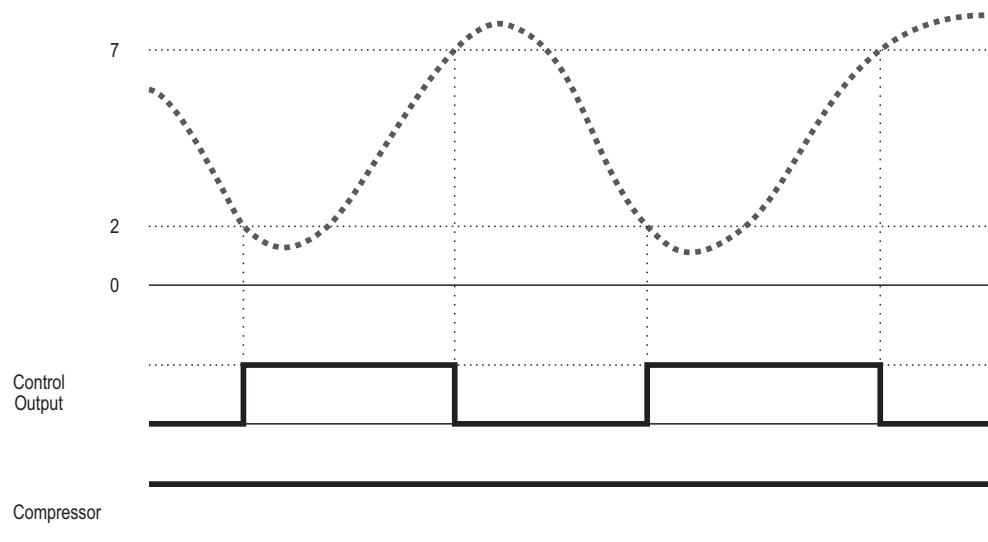

Shutdown of Compressors:

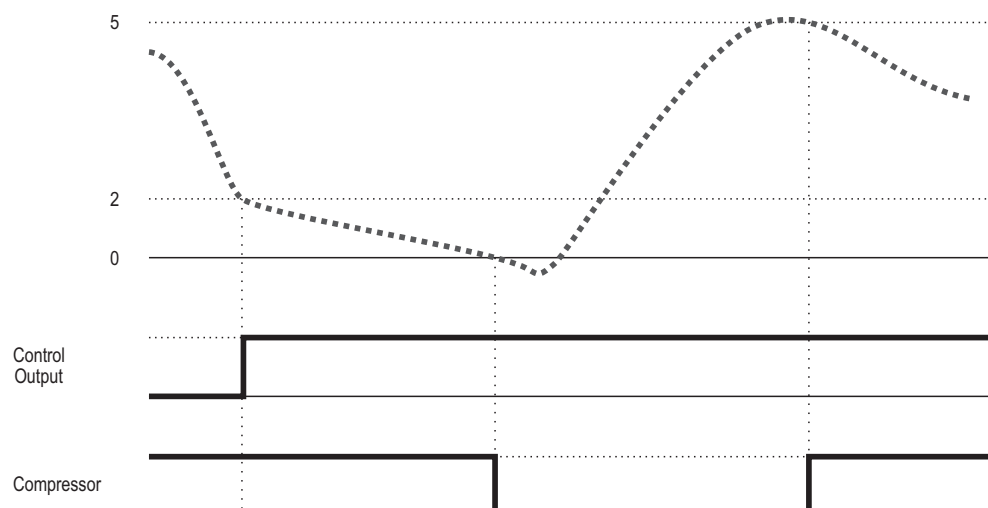



18.ALARMS

The **RCK-862^{plus}** controller has an alarm system in which it is possible to configure protection or display-only alarms. All alarm settings are linked to the suction and discharge pressure switches. In the event of an alarm, an audible warning will sound and remain active until one of the following conditions occurs:

- The alarm condition no longer occurs, and the alarm is not in a manual reset condition.
- A manual reset was performed (Control Menu).
- The audible warning has been inhibited (by pressing the  key for 5 seconds).

If the audible warning function is not desired, it can be disabled in menu 2.4.

18.1 Viewing alarms

One touch on the key  displays active Alarms, a second touch displays alarms on reset and a third touch displays the Alarm History screen. Up to 99 records are stored in each of these three lists, and you can navigate between the records using the keys  and .

When the list is complete, new alarms overwrite older alarm records.

Each alarm record has information about the reason for the alarm, which pressure switch the occurrence was on, start time and time the event stopped.

To delete the alarm records, it is necessary to be viewing the **alarm history** list, press and hold the  key for 3 seconds and confirm the request.

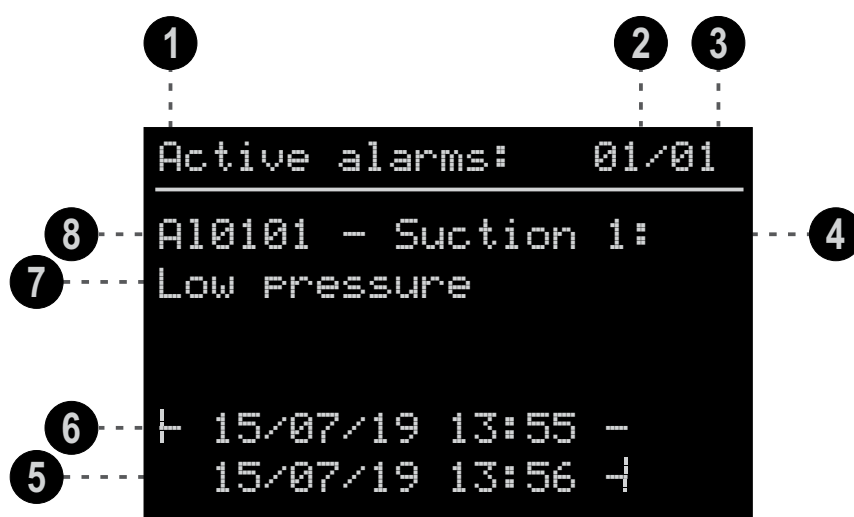

- 1** – Alarm list displayed:
Active alarms: Alarms that are active, in alarm condition
Resets: Alarms that are no longer active but are preventing the operation of a pressure switch. These alarms are in automatic or manual reset condition
Alarm history: Records all alarms that are no longer active or in reset condition
- 2** – Record number of the list being displayed. Record 1 is always the most recent
- 3** – Number of records in each alarm list
- 4** – Pressure switch where the alarm occurred
- 5** – Time the alarm stopped occurring
If the alarm exit time is marked (*), it means that the controller was de-energized while the alarms were active, and it is not possible to determine the exact time when the alarm stopped occurring. In this case, the time when the controller was energized after this occurrence is displayed
- 6** – Alarm start time
- 7** – Reason for alarm
- 8** – Alarm identifier code. See alarm table

18.ALARMS

18.2 Automatic resets:

It is possible to configure automatic resets for protection alarms. In the reset menu (1 . 4 . 4) it is possible to configure the Number of reset attempts (1 . 4 . 4 . 1), the intervals between attempts and a period within which attempts will be made.

If the number of attempts is set to the minimum "Off" value, the reset must be manual only. If the maximum value "Always" is set, the **RCK-862 plus** does not limit the number of reset attempts, it only respects the times.

If the value is set between 1 and 10, this number of attempts will be made within the configured reset period (1 . 4 . 4 . 3) and after this number of attempts, a manual reset should be made.

With each occurrence of protection alarms, it will be checked how many alarms of the same type occurred within the configured period. If it is higher than the configured value, the pressure switch will be blocked in alarm condition and a manual reset via Sitrad or via the interface in the control menu option Reset will be necessary.

If the reset period has elapsed and the number of configured attempts has not occurred, the attempt counter will be reset.



Attention: As a factory default, the suction and discharge alarms are disabled and for their use it is necessary to configure an appropriate limit depending on the application.

Number of attempts = 3

Example 1: Time for Retry = 5 minutes

Reset period = 1 hour

In the event of a protection alarm, it will be checked if 3 other alarms of the same type have occurred within the last hour, if so, the pressure switch will be blocked, if not, it will be reset after 5 minutes.

Number of attempts = always

Example 2: Time for Retry = 5 minutes

Reset period = 1 hour

In the event of a protection alarm, the pressure switch will be reset after 5 minutes without limit of attempts and the setting of the reset period is indifferent.

18.3 Outputs signaling

It is possible to configure up to 6 digital alarm outputs through menu 1 . 4 . 5. Each output, when configured, will actuate together with the visual alarm. The activation mode of this alarm output can be switched on or cycling.

Example: Configuring an output through the menu 1.4.5.1.

Pressure switch: Suction 1

Output function: Low pressure

Time on: 5 seconds

Time off: 5 seconds

Digital output = O5 (digital output 5)

In the event of an alarm for suction pressure switch 1, digital output 5 will cycle with Ton and Toff = 5 seconds.

And it will be turned off after leaving the alarm condition, or after the reset.

Example: Configuring an output via the menu 1.4.5.2.

Pressure switch: Suction 1

Output function: Low pressure

Time on: 0 seconds

Time off: 0 seconds

Digital output = O6 (digital output 6)

In the event of a low-pressure alarm on suction 1, output 6 will be activated until manual or automatic reset is carried out.

18.ALARMS

18.4 Alarm tables

18.4.1 System alarms

Alarm	Description	Effect
AL0001	Clock not set	Indicative alarm.
AL0002	PPP	Blocking control functions. Resetting controller parameters.
AL0003	Manual reset record	Indicative alarm.
AL0004	ECAL	Blocking control functions. (Contact Full Gauge Controls).

18.4.2 Suction alarms: The **RCK-862 plus** can control up to 3 suction pressure switches. The address of each pressure switch in the alarm nomenclature is represented by the letter "x". Where "x" can be 1, 2 or 3 and represents suction pressure switches 1, 2 or 3, respectively.

Alarm	Description	Effect
AL0x01	Low pressure	Turns off all compressors on the suction line and fans on the discharge line, regardless of the time set between shutdowns (in case of more than one suction in the group with running compressors, the fans are not turned off). If the function of the menu 1.7.1 - Suction x: Enable Pump Down is set to Yes, one of the compressors remains on until it reaches the Pump Down pressure or the time set for the respective group.
AL0x02	High pressure	Indicative alarm.
AL0x03	Low saturation temperature	Turns off all compressors from the suction line, disregarding the time between shutdowns. If the menu function 1.7.1 - Suction x: Enable Pump Down is configured as Yes, one of the compressors remains on until reaching the pressure or the Pump Down time configured for the respective group.
AL0x04	High saturation temperature	Indicative alarm.
AL0x05	Low secondary fluid inlet temperature	Turns off all compressors from the suction line, disregarding the time between shutdowns. If the menu function 1.7.1 - Suction x: Enable Pump Down is configured as Yes, one of the compressors remains on until reaching the pressure or the Pump Down time configured for the respective group.
AL0x06	High secondary fluid inlet temperature	Indicative alarm.
AL0x07	Low secondary fluid outlet temperature	Turns off all compressors from the suction line, disregarding the time between shutdowns. If the menu function 1.7.1 - Suction x: Enable Pump Down is configured as Yes, one of the compressors remains on until reaching the pressure or the Pump Down time configured for the respective group.
AL0x08	High secondary fluid outlet temperature	Indicative alarm.
AL0x09	Critical superheating	Disconnect all compressors from the suction pressure switch. Ignores the time between shutdowns.
AL0x10	Low superheating	Indicative alarm.
AL0x11	High superheating	Indicative alarm.
AL0x12	Compressor safety input 1	Shuts off compressor 1. The inhibition and validation times available in menu 1.4.1 do not apply to this alarm.
AL0x13	Compressor safety input 2	Shuts off compressor 2. The inhibition and validation times available in menu 1.4.1 do not apply to this alarm.
AL0x14	Compressor safety input 3	Shuts off compressor 3. The inhibition and validation times available in menu 1.4.1 do not apply to this alarm.
AL0x15	Compressor safety input 4	Shuts off compressor 4. The inhibition and validation times available in menu 1.4.1 do not apply to this alarm.
AL0x16	Compressor safety input 5	Shuts off compressor 5. The inhibition and validation times available in menu 1.4.1 do not apply to this alarm.

18.ALARMS

Alarm	Description	Effect
AL0x17	Compressor safety input 6	Shuts off compressor 6. The inhibition and validation times available in menu 1.4.1 do not apply to this alarm.
AL0x18	Low pressure digital input (LP)	Turns off all compressors on the suction line and fans on the discharge line, regardless of the time set up between shutdowns (if there is more than one suction line in the group with running compressors, the fans remain on). The inhibition and validation times available in menu 1.4.1 do not apply to this alarm.
AL0x19	High pressure digital input (HP)	Indicative alarm. The inhibition and validation times available in menu 1.4.1 do not apply to this alarm.
AL0x20	Compressor 1 maintenance time	Indicative alarm
AL0x21	Compressor 2 maintenance time	Indicative alarm
AL0x22	Compressor 3 maintenance time	Indicative alarm
AL0x23	Compressor 4 maintenance time	Indicative alarm
AL0x24	Compressor 5 maintenance time	Indicative alarm
AL0x25	Compressor 6 maintenance time	Indicative alarm
AL0x26	High temperature in compressor 1	Shuts off the compressor 1
AL0x27	High temperature in compressor 2	Shuts off the compressor 2
AL0x28	High temperature in compressor 3	Shuts off the compressor 3
AL0x29	High temperature in compressor 4	Shuts off the compressor 4
AL0x30	High temperature in compressor 5	Shuts off the compressor 5
AL0x31	High temperature in compressor 6	Shuts off the compressor 6
AL0x32	Pressure sensor reading difference main and reserve	Indicative alarm
AL0x33	Difference in reading of the sensors fluid inlet temperature	Indicative alarm
AL0x34	Difference in reading of the sensors secondary fluid outlet temperature main and reserve	Indicative alarm
AL0x35	External alarm 1	Indicative alarm
AL0x36	External alarm 2	Indicative alarm
AL0x37	External alarm 3	Indicative alarm
AL0x38	External alarm 4	Indicative alarm
AL0x39	External alarm 5	Indicative alarm
AL0x40	External alarm 6	Indicative alarm
AL0x41	External alarm 7	Indicative alarm
AL0x42	External alarm 8	Indicative alarm
AL0x43	External alarm 9	Indicative alarm
AL0x44	External alarm 10	Indicative alarm
AL0x45	External fault 1	Turns off all compressors on the suction line and fans on the discharge line, regardless of the time set up between shutdowns (if there is more than one suction line in the group with running compressors, the fans remain on). The inhibition and validation times available in menu 1.4.1 do not apply to this alarm.
AL0x46	External fault 2	Turns off all compressors on the suction line and fans on the discharge line, regardless of the time set up between shutdowns (if there is more than one suction line in the group with running compressors, the fans remain on). The inhibition and validation times available in menu 1.4.1 do not apply to this alarm.

18.ALARMS

Alarm	Description	Effect
AL0x47	External fault 3	Turns off all compressors on the suction line and fans on the discharge line, regardless of the time set up between shutdowns (if there is more than one suction line in the group with running compressors, the fans remain on). The inhibition and validation times available in menu 1.4.1 do not apply to this alarm.
AL0x48	External fault 4	Turns off all compressors on the suction line and fans on the discharge line, regardless of the time set up between shutdowns (if there is more than one suction line in the group with running compressors, the fans remain on). It can only be reset manually, meaning that automatic reset does not apply to this alarm. The inhibition and validation times available in menu 1.4.1 do not apply to this alarm.
AL0x49	External fault 5	Turns off all compressors on the suction line and fans on the discharge line, regardless of the time set up between shutdowns (if there is more than one suction line in the group with running compressors, the fans remain on). It can only be reset manually, meaning that automatic reset does not apply to this alarm. The inhibition and validation times available in menu 1.4.1 do not apply to this alarm.
AL0x50	External fault 6	Turns off all compressors from the group's suction lines considering the time between shutdowns. If the menu function 1.7.1 - Suction x: Enable Pump Down is set to Yes, one of the compressors remains on until it reaches the pressure or pump down time set for the respective group.
AL0x51	External fault 7	Turns off all compressors from the group's suction lines, regarding the time between shutdowns. If the menu function 1.7.1 - Suction x: Enable Pump Down is set to Yes, one of the compressors remains on until it reaches the pressure or pump down time set for the respective group.
AL0x52	External fault 8	Turns off all compressors from the group's suction lines considering the time between shutdowns. If the menu function 1.7.1 - Suction x: Enable Pump Down is set to Yes, one of the compressors remains on until it reaches the pressure or pump down time set for the respective group.
AL0x53	External fault 9	Turns off all compressors from the group's suction lines, regarding the time between shutdowns. If the menu function 1.7.1 - Suction x: Enable Pump Down is set to Yes, one of the compressors remains on until it reaches the pressure or pump down time set for the respective group.
AL0x54	External fault 10	Turns off all compressors from the group's suction lines, disregarding the time between shutdowns. If the menu function 1.7.1 - Suction x: Enable Pump Down is set to Yes, one of the compressors remains on until it reaches the pressure or pump down time set for the respective group.

18.ALARMS

Alarm	Description	Effect
AL0x55	Oil failure 1	Shuts off the compressor 1. It can only be reset manually, i.e. automatic reset does not apply to this alarm. The inhibition time (1.4.1.4) does not apply to this alarm.
AL0x56	Oil failure 2	Shuts off the compressor 2. It can only be reset manually, i.e. automatic reset does not apply to this alarm. The inhibition time (1.4.1.4) does not apply to this alarm.
AL0x57	Oil failure 3	Shuts off the compressor 3. It can only be reset manually, i.e. automatic reset does not apply to this alarm. The inhibition time (1.4.1.4) does not apply to this alarm.
AL0x58	Oil failure 4	Shuts off the compressor 4. It can only be reset manually, i.e. automatic reset does not apply to this alarm. The inhibition time (1.4.1.4) does not apply to this alarm.
AL0x59	Oil failure 5	Shuts off the compressor 5. It can only be reset manually, i.e. automatic reset does not apply to this alarm. The inhibition time (1.4.1.4) does not apply to this alarm.
AL0x60	Oil failure 6	Shuts off the compressor 6. It can only be reset manually, i.e. automatic reset does not apply to this alarm. The inhibition time (1.4.1.4) does not apply to this alarm.

18.4.3 Discharge alarms: The **RCK-862 plus** can control up to 3 discharge pressure switches. The address of each pressure switch in the alarm nomenclature is represented by the letter "x". Where "x" can be 4, 5 or 6 and represents discharge pressure switches 1, 2 or 3, respectively.

Example: AL0x01

- 4 - Referring to Discharge 1
- 5 - Referring to Discharge 2
- 6 - Referring to Discharge 3

Alarm	Description	Effect
AL0x01	Low pressure	Shut off all fans on the discharge pressure switch. Ignores the time between deactivations.
AL0x02	High pressure	Turns off all compressors from the group's suction lines considering the time between shutdowns. If the menu function 1.7.1 - Suction x: Enable Pump Down is set to Yes, one of the compressors remains on until it reaches the pressure or pump time down configured for the respective group.
AL0x03	Critical high pressure	Turns off all compressors on the suction line and fans on the discharge line, regardless of the time set between shutdowns (in case of more than one suction in the group with running compressors, the fans are not turned off). If the function of the menu 1.7.1 - Suction x: Enable Pump Down is set to Yes, one of the compressors remains on until it reaches the Pump Down pressure or the time set for the respective group. The validation time for pressure alarms (1.4.1.1) does not apply to this alarm.
AL0x04	Low saturation temperature	Turns off all fans of the discharge pressure switch. Ignore time between shutdowns
AL0x05	High saturation temperature	Turns off all compressors from the group's suction lines considering the time between shutdowns. If the menu function 1.7.1 - Suction x: Enable Pump Down is set to Yes, one of the compressors remains on until it reaches the pressure or pump time down configured for the respective group.

18.ALARMS

Alarm	Description	Effect
AL0x06	Critical high saturation temperature	Turns off all compressors from the group's suction lines, disregarding the time between shutdowns. If the menu function 1.7.1 - Suction x: Enable Pump Down is configured as Yes, one of the compressors remains on until it reaches the pressure or pump time down configured for the respective group. The validation time for temperature alarms (1.4.1.2) does not apply to this alarm.
AL0x07	Low liquid line temperature	Turns off all fans of the discharge pressure switch. Ignore time between shutdowns
AL0x08	High liquid line temperature	Turns off all compressors from the group's suction lines considering the time between shutdowns. If the menu function 1.7.1 - Suction x: Enable Pump Down is set to Yes, one of the compressors remains on until it reaches the pressure or pump time down configured for the respective group.
AL0x09	Critical high liquid line temperature	Turns off all compressors from the group's suction lines, disregarding the time between shutdowns. If the menu function 1.7.1 - Suction x: Enable Pump Down is configured as Yes, one of the compressors remains on until it reaches the pressure or pump time down configured for the respective group. The validation time for temperature alarms (1.4.1.2) does not apply to this alarm.
AL0x10	Low subcooling	Indicative alarm.
AL0x11	High subcooling	Indicative alarm.
AL0x12	Fan safety input 1	Shuts off the fan 1. The inhibition and validation times configured in menu 1.4.1 do not apply to this alarm.
AL0x13	Fan safety input 2	Shuts off the fan 2. The inhibition and validation times configured in menu 1.4.1 do not apply to this alarm.
AL0x14	Fan safety input 3	Shuts off the fan 3. The inhibition and validation times configured in menu 1.4.1 do not apply to this alarm.
AL0x15	Fan safety input 4	Shuts off the fan 4. The inhibition and validation times configured in menu 1.4.1 do not apply to this alarm.
AL0x16	Fan safety input 5	Shuts off the fan 5. The inhibition and validation times configured in menu 1.4.1 do not apply to this alarm.
AL0x17	Fan safety input 6	Shuts off the fan 6. The inhibition and validation times configured in menu 1.4.1 do not apply to this alarm.
AL0x18	Low pressure digital input (LP)	Shut off all fans on the discharge pressure switch. Ignores the time between shutdowns. The inhibition and validation times configured in menu 1.4.1 do not apply to this alarm.
AL0x19	High pressure digital input (HP)	Turns off all the compressors of the suction lines of the group, disregarding the time between shutdowns and turns on all the fans of the discharge line. The inhibition and validation times configured in menu 1.4.1 do not apply to this alarm.
AL0x20	Maintenance time for fan 1	Indicative alarm.
AL0x21	Maintenance time for fan 2	Indicative alarm.
AL0x22	Maintenance time for fan 3	Indicative alarm.
AL0x23	Maintenance time for fan 4	Indicative alarm.
AL0x24	Maintenance time for fan 5	Indicative alarm.
AL0x25	Maintenance time for fan 6	Indicative alarm.

18.ALARMS

Alarm	Description	Effect
AL0x26	Adiabatic condensation validation time	Shut off the adiabatic condensation outlet. This alarm remains active for 1 minute. The validation time for temperature alarms (1.4.1.2) does not apply to this alarm.
AL0x27	Difference between main and backup pressure sensors	Indicative alarm.
AL0x28	Difference between main and backup temperature sensors	Indicative alarm.
AL0x29	External alarm 1	Indicative alarm.
AL0x30	External alarm 2	Indicative alarm.
AL0x31	External alarm 3	Indicative alarm.
AL0x32	External alarm 4	Indicative alarm.
AL0x33	External alarm 5	Indicative alarm.
AL0x34	External alarm 6	Indicative alarm.
AL0x35	External alarm 7	Indicative alarm.
AL0x36	External alarm 8	Indicative alarm.
AL0x37	External alarm 9	Indicative alarm.
AL0x38	External alarm 10	Indicative alarm.
AL0x39	External fault 1	Shut off all fan on the discharge pressure switch. Ignores the time between shutdowns. The inhibition and validation times configured in menu 1.4.1 do not apply to this alarm.
AL0x40	External fault 2	Shut off all fan on the discharge pressure switch. Ignores the time between shutdowns. The inhibition and validation times configured in menu 1.4.1 do not apply to this alarm.
AL0x41	External fault 3	Shut off all fan on the discharge pressure switch. Ignores the time between shutdowns. The inhibition and validation times configured in menu 1.4.1 do not apply to this alarm.
AL0x42	External fault 4	Shuts off all discharge pressure switch fans. Ignores the time between deactivations. It can only be reset manually, meaning automatic reset does not apply to this alarm. The inhibition and validation times configured in menu 1.4.1 do not apply to this alarm.
AL0x43	External fault 5	Shuts off all discharge pressure switch fans. Ignores the time between deactivations. It can only be reset manually, meaning automatic reset does not apply to this alarm. The inhibition and validation times configured in menu 1.4.1 do not apply to this alarm.
AL0x44	External fault 6	Shut off all fan on the discharge pressure switch. Respect the time between shutdowns.
AL0x45	External fault 7	Shut off all fan on the discharge pressure switch. Respect the time between shutdowns.
AL0x46	External fault 8	Shut off all fan on the discharge pressure switch. Respect the time between shutdowns.
AL0x47	External fault 9	Shut off all fan on the discharge pressure switch. Respect the time between shutdowns.
AL0x48	External fault 10	Shut off all fan on the discharge pressure switch. Respect the time between shutdowns.

18.ALARMS

18.4.4 Individual pressure switch alarms: The **RCK-862^{plus}** can control up to 3 individual pressure switches. The address of each pressure switch in the alarm nomenclature is represented by the letter "x". Where "x" can be 7, 8 or 9 and represents, respectively, the individual pressure switches 1, 2 or 3.

Example: AL0x01

- 7 - Referring to individual pressure switch 1
- 8 - Referring to individual pressure switch 2
- 9 - Referring to individual pressure switch 3

Alarm	Description	Effect
AL0x01	Low pressure	Indicative alarm.
AL0x02	High pressure	Indicative alarm.

18.4.5 Individual thermostat alarms: The **RCK-862^{plus}** can control up to 6 individual thermostats. The address of each thermostat in the alarm nomenclature is represented by the letter "x". Where "x" can be 10, 11, 12, 13, 14 and 15, representing the individual thermostats 1, 2, 3, 4, 5 or 6, respectively.

Example: AL0x01

- 10 - Referring to individual thermostat switch 1
- 11 - Referring to individual thermostat switch 2
- 12 - Referring to individual thermostat switch 3
- 13 - Referring to individual thermostat switch 4
- 14 - Referring to individual thermostat switch 5
- 15 - Referring to individual thermostat switch 6

Alarm	Description	Effect
AL0x01	Low temperature	Indicative alarm.
AL0x02	High temperature	Indicative alarm.

18.4.6 Rotating output alarms: The **RCK-862^{plus}** can control up to 3 sets of rotating outputs. The address of each set of rotating outputs in the alarm nomenclature is represented by the letter "x". Where "x" can be 16, 17 and 18, representing sets of pumps 1, 2 or 3, respectively.

Example: AL0x01

- 16 - Referring set of pumps 1
- 17 - Referring set of pumps 2
- 18 - Referring set of pumps 3

Alarm	Description	Effect
ALxx01	Output 1 alarm	Shuts off Pump 1 and activates the next pump in Rotation or Backup mode. The inhibition and validation times configured in menu 1.4.1 do not apply to this alarm.
ALxx02	Output 2 alarm	Shuts off Pump 2 and activates the next pump in Rotation or Backup mode. The inhibition and validation times configured in menu 1.4.1 do not apply to this alarm.
ALxx03	Output 3 alarm	Shuts off Pump 3 and activates the next pump in Rotation or Backup mode. The inhibition and validation times configured in menu 1.4.1 do not apply to this alarm.

18.4.7 Communication alarms with expansions: Communication failure alarms with expansion modules are triggered immediately upon detection, without waiting for the inhibition and validation times configured in menu 1.4.1.

Alarm	Description	Effect
AL1901	No communication with expansion 1	Shut off all controller outputs (except alarm outputs).
AL1902	No communication with expansion 2	Shut off all controller outputs (except alarm outputs).
AL1903	No communication with expansion 3	Shut off all controller outputs (except alarm outputs).
AL1904	No communication with expansion 4	Shut off all controller outputs (except alarm outputs).
AL1905	No communication with expansion 5	Shut off all controller outputs (except alarm outputs).
AL1906	No communication with expansion 6	Shut off all controller outputs (except alarm outputs).
AL1907	No communication with expansion 7	Shut off all controller outputs (except alarm outputs).

18.ALARMS

Alarm	Description	Effect
AL1908	No communication with expansion 8	Shut off all controller outputs (except alarm outputs).
AL1909	No communication with expansion 9	Shut off all controller outputs (except alarm outputs).
AL1910	No communication with expansion 10	Shut off all controller outputs (except alarm outputs).

18.4.8 Sensor Failure Alarms: The address of each of the six sensor failures in the alarm nomenclature is represented by the letter "x". Where "x" takes values between 1 and 6, it corresponds to sensors 1 to 6, respectively.

Sensor failure alarms are triggered immediately upon detection, without waiting for the inhibition and validation times configured in menu 1.4.1.

Alarm	Description	Effect
AL2001	Sensor failure S1	In the Suction and Discharge groups, control is assumed by the sensor failure logic configured in menu 1.5. For other logics, the control output is turned off.
AL2002	Sensor failure S2	In the Suction and Discharge groups, control is assumed by the sensor failure logic configured in menu 1.5. For other logics, the control output is turned off.
AL2003	Sensor failure S3	In the Suction and Discharge groups, control is assumed by the sensor failure logic configured in menu 1.5. For other logics, the control output is turned off.
AL2004	Sensor failure S4	In the Suction and Discharge groups, control is assumed by the sensor failure logic configured in menu 1.5. For other logics, the control output is turned off.
AL2005	Sensor failure S5	In the Suction and Discharge groups, control is assumed by the sensor failure logic configured in menu 1.5. For other logics, the control output is turned off.
AL2006	Sensor failure S6	In the Suction and Discharge groups, control is assumed by the sensor failure logic configured in menu 1.5. For other logics, the control output is turned off.

For expansions, add 01 to the reference AL2x01 for each of the 10 expansions, where "x" represents the corresponding expansion number.

Example:

Expansion 1: AL2101 → AL2108 Expansion 5: AL2501 → AL2508 Expansion 9: AL2901 → AL2908

Expansion 2: AL2201 → AL2208 Expansion 6: AL2601 → AL2608 Expansion 10: AL3001 → AL3008

Expansion 3: AL2301 → AL2308 Expansion 7: AL2701 → AL2708

Expansion 4: AL2401 → AL2408 Expansion 8: AL2801 → AL2808

Alarm	Description	Effect
AL2x01	Sensor failure S1	In the Suction and Discharge groups, control is assumed by the sensor failure logic configured in menu 1.5. For other logics, the control output is turned off.
AL2x02	Sensor failure S2	In the Suction and Discharge groups, control is assumed by the sensor failure logic configured in menu 1.5. For other logics, the control output is turned off.
AL2x03	Sensor failure S3	In the Suction and Discharge groups, control is assumed by the sensor failure logic configured in menu 1.5. For other logics, the control output is turned off.
AL2x04	Sensor failure S4	In the Suction and Discharge groups, control is assumed by the sensor failure logic configured in menu 1.5. For other logics, the control output is turned off.
AL2x05	Sensor failure S5	In the Suction and Discharge groups, control is assumed by the sensor failure logic configured in menu 1.5. For other logics, the control output is turned off.
AL2x06	Sensor failure S6	In the Suction and Discharge groups, control is assumed by the sensor failure logic configured in menu 1.5. For other logics, the control output is turned off.
AL2x07	Sensor failure S7	In the Suction and Discharge groups, control is assumed by the sensor failure logic configured in menu 1.5. For other logics, the control output is turned off.
AL2x08	Sensor failure S8	In the Suction and Discharge groups, control is assumed by the sensor failure logic configured in menu 1.5. For other logics, the control output is turned off.

18.ALARMS

Alarm	Description	Effect
AL2x09	Sensor failure S9	In the Suction and Discharge groups, control is assumed by the sensor failure logic configured in menu 1.5. For other logics, the control output is turned off.
AL2x10	Sensor failure S10	In the Suction and Discharge groups, control is assumed by the sensor failure logic configured in menu 1.5. For other logics, the control output is turned off.

18.4.9 Antifreeze Alarms: The address for each of the six frost protection groups in the alarm nomenclature is represented by the letter "x". Here, "x" takes values from 0 to 5, representing the group, respectively from 1 to 6.

Exemplo: AL4x01

- 0 - Referring to antifreeze group 1
- 1 - Referring to antifreeze group 2
- 2 - Referring to antifreeze group 3
- 3 - Referring to antifreeze group 4
- 4 - Referring to antifreeze group 5
- 5 - Referring to antifreeze group 6

Alarm	Description	Effect
AL4x01	Low temperature differential	Indicative alarm.
AL4x02	High temperature differential	Indicative alarm.
AL4x03	Low temperature	Shuts off the compressors in the suction line associated with the respective antifreeze function group. The inhibition and validation times configured in menu 1.4.1 do not apply to this alarm.

19.MAIN MENU

The Main Menu is accessible by pressing the key  for at least 3 seconds when using the Groups, Suction or Discharge keys.

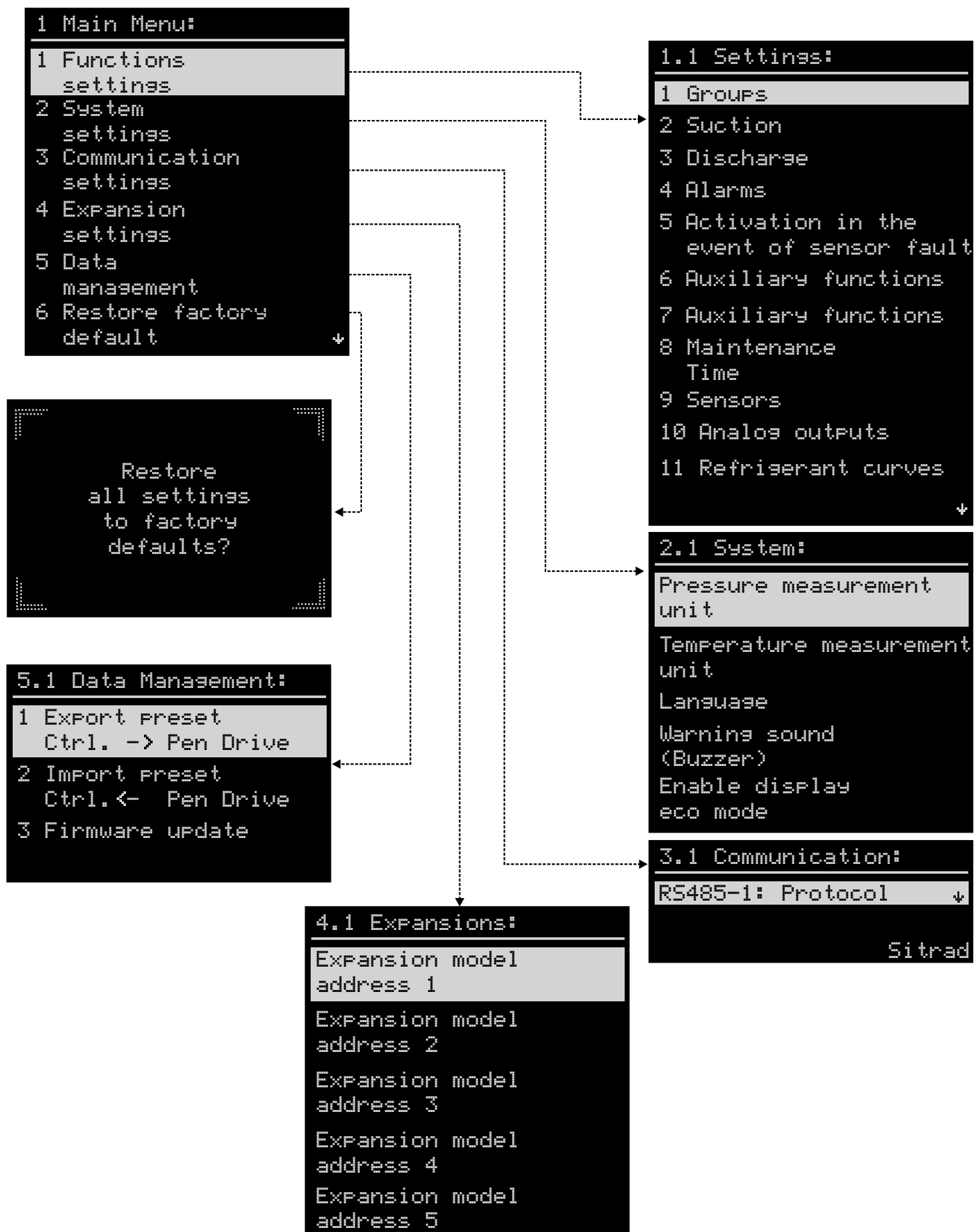

19.1 Functions Settings:

For a complete description of all parameters see chapter 20 - Parameter Table.

19.MAIN MENU

19.2 System settings

Feature	Description	Minimum	Maximum	Standard	Unit
2.1	Pressure measurement unit	Psi	bar	Psi	-
2.2	Temperature measurement unit	°C	°F	°C	-
2.3	Language	Portuguese	Spanish	Portuguese	-
2.4	Warning sound (Buzzer)	Yes	No	Yes	-
2.5	Enable display eco mode	Yes	No	Yes	-
2.6	Allows setpoint adjustment in the control menu	Yes	No	No	-

2.1 Pressure measurement unit:

Pressure measurement unit used by the controller: Psi or Bar.

2.2 Temperature measurement unit:

Temperature measurement unit used by the controller: Celsius or Fahrenheit.

2.3 Language:

Controller language: Portuguese, English or Spanish.

2.4 Buzzer:

Enables the audible warning function in case of alarm and controller feedback.

2.5 Enables display eco mode:

Enables display sleep mode. After a period of 15 minutes the display brightness decreases, increasing its life span and decreasing energy consumption.



Note: When ECO mode is active, just a short press on any of the keys will disable it.

2.6 Allows setpoint adjustment in the control menu:

Allows the setpoint of the suctions to be adjusted through the control menu without requiring a change in access level.

19.3 Communication settings:

The **RCK-862 plus** features two independently configurable RS-485 communication ports for communication with Sitrad software or supervisory systems using the MODBUS protocol.

Feature	Description	Minimum	Maximum	Standard	Unit
3.1	RS485 - 1: Protocol	0	1	0	-
3.2	RS485 - 1: Address	1	247	1	-
3.3	RS485 - 1: Baud rate	0	5	5	-
3.4	RS485 - 1: Parity	0	2	0	-
3.5	RS485 - 1: Stop bits	1	2	1	-
3.6	RS485 - 2: Protocol	0	1	1	-
3.7	RS485 - 2: Address	1	247	1	-
3.8	RS485 - 2: Baud rate	0	5	5	-
3.9	RS485 - 2: Parity	0	2	0	-
3.10	RS485 - 2: Stop bits	1	2	1	-

19.MAIN MENU

3. 1 RS485-X/Protocol:

Communication protocol of RS485-X port.

- 0 = Sitrad
- 1 = MODBUS



Note: For communication with FG-HMI 4.3 HMI use Sitrad's protocol.

3. 2 RS485-X/Address:

Network address of the RS485-X port. (Available for Sitrad and MODBUS protocols).

3. 3 RS485-X/Baud rate:

Communication data rates (Available for the MODBUS protocol only).

- 0 = 4800
- 1 = 9600
- 2 = 19200
- 3 = 38400
- 4 = 57600
- 5 = 115200

3. 4 RS485-X/Parity:

Communication protocol parity (Only available for MODBUS protocol).

- 0 = no parity
- 1 = even parity
- 2 = odd parity

3. 5 RS485-X/Stop bits:

Number of stop bits (Only available for the MODBUS protocol).

- 1 = 1 stop bit
- 2 = 2 stop bits

19.3.1 Communication with Sitrad:

Communication with the Sitrad Pro software follows the following network structure:

For more information access: www.sitrad.com



CONNECTION BLOCK

It is used to connect more than one controller to the Interface. The wire connections must be made as follows: Terminal A of the controller connect to terminal A of the connection block, which in turn, must be connected to terminal A of the Interface. Repeat the procedure for terminals B and $\frac{1}{2}$, being $\frac{1}{2}$ the cable screen.

*INTERFACE SERIAL RS-485

Device used to establish the connection of Full Gauge Controls instruments with Sitrad*.

Product NOT compatible with:

- TCP-485 versions earlier than 4.01;
- TCP-485 WiFi version 1;
- TCP-485 WiFi Log version 1.

Full Gauge offers different interface options, including technologies such as USB, Ethernet, Wifi, among others.

For more information, consult Full Gauge Controls.

Sold separately.

MODBUS PROTOCOL

The controller allows you to configure the RS-485 communication port for the MODBUS-RTU protocol. For more information about the implemented commands and the registration table, contact Full Gauge Controls.



19.3.2 Communication MODBUS:

The **RCK-862 plus** allows you to configure the RS-485 communication port for the MODBUS-RTU protocol. For more information about the implemented commands and the registration table, contact Full Gauge Controls.

19.4 Expansions:

The **RCK-862 plus** has the possibility to expand the number of inputs and outputs using expansion modules. This feature allows you to control more complex systems, increasing the number of controlled devices and expanding the possibilities for monitoring and protecting the system.

Through the Exp communication port it is possible to connect up to ten expansion modules, gradually expanding the options of inputs and outputs available to the existing logic. It is recommended to use cables with screens / shields and minimum diameter of 24AWG or (0.5mm) for communication between the expansions and the module.

For example, when using and RCK-461 expansion module, 8 more digital outputs (5 STPS and 3 SSR), 2 0-10V analog outputs, 6 dry contact digital inputs and 8 configurable analog inputs for sensors (NTC or 4-20mA) are added.

To enable communication between the **RCK-862 plus** and the expansion modules, you must configure the desired module in Expansion Model address 1 to 9 (4. 1 a 4. 1 $\frac{1}{2}$) and assign the same address to the expansion module. Each expansion module must have an address between 1 to 10, without repeating addresses.

19.MAIN MENU

In each expansion module, an address must be configured between 1 and 10, without repetition. To do this, press the **SET** key for 2 seconds, select the desired address using the keys **↑** and **↓** and press **SET** again to confirm.

On the **RCK-862_{plus}** the module model used at each address must be selected. To do this, access the menu 4.x, where x represents the address from 1 to 10, and select the corresponding model.

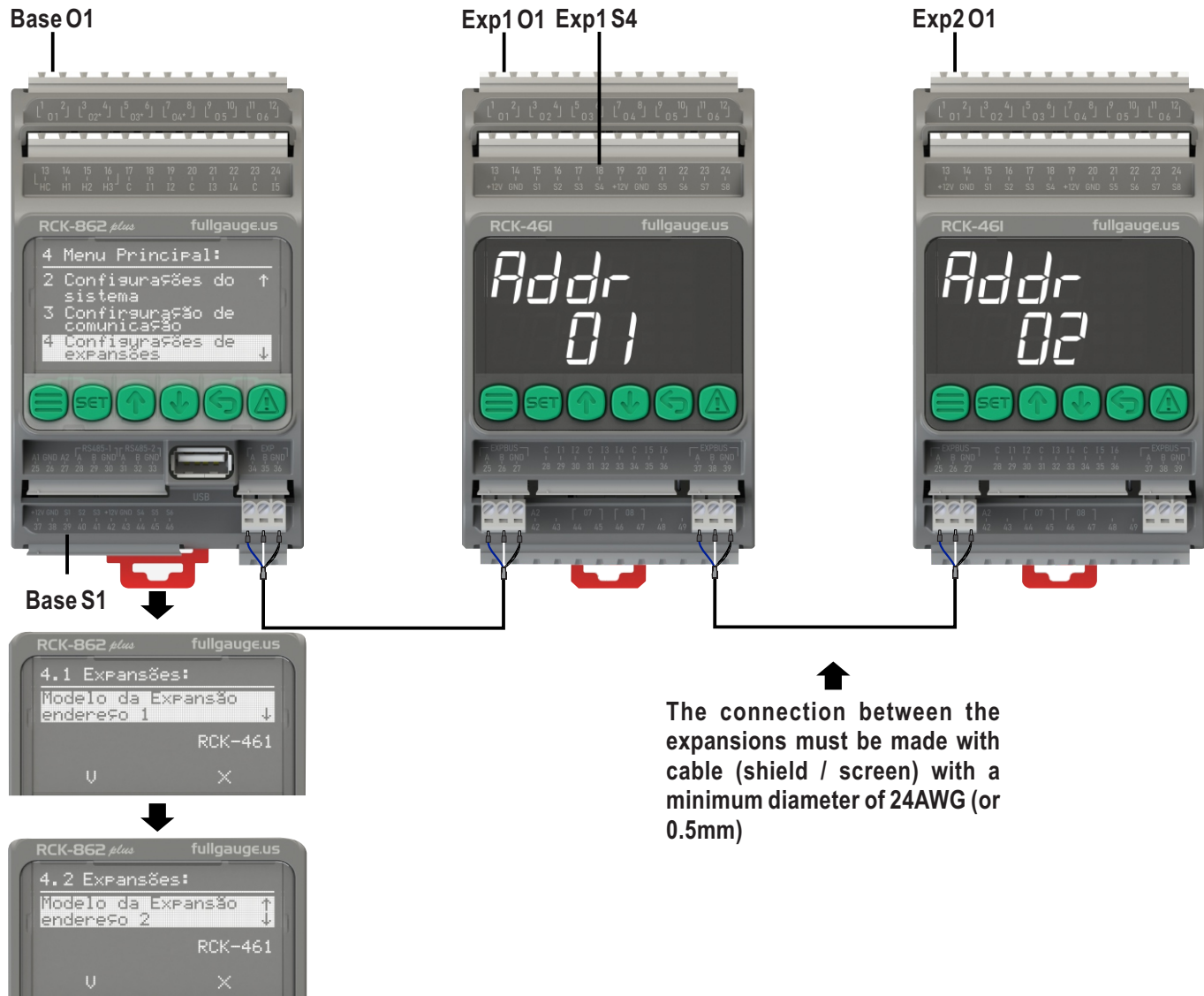

When configuring the expansions, the **RCK-862_{plus}** automatically expands the possible input and output options for selection.

Example:

```

1.2.1.34 Suction 1:
Compressor 1
Main Output

Base 01
Base 02
...
Base 06
EXP 1 01
...
EXP 1 08
EXP 2 01
...
EXP 2 08
    
```

19.MAIN MENU

19.5 Data management:

The **RCK-862_{plus}** has a USB port with support for communication via pen drive, where it is possible to manage presets and update the controller firmware. Access path: Main Menu → Data manager.

19.5.1 Export preset → RCK-862_{plus} → Pendrive (5.1):

Copies the preset from the controller to the memory of the Pen drive.

The file will be stored in the RCK-862 folder and will be named according to the following logic:

MODEL_AAMMDD_HHMMSS.rec, where:

MODEL = product model, AA = year, MM = month, DD = day, HH = hour, MM = minute, SS = second.

Example: A preset exported on an **RCK-862_{plus}**, on 08/02/2019 at 13:30:00 will have the name RCK-862_190802_133000.rec.

19.5.2 Import preset → RCK-862_{plus} → Pendrive (5.1):

Copies the preset from a pen drive to the controller memory.

RCK looks for the preset in the RCK-862 folder. The preset name can be a maximum of 32 characters, including the extension (.rec).

Note: The RCK-862 folder must contain a maximum of 32 preset files.

19.5.3 Firmware update (5.3):

Updates the controller firmware.

The file must be inside the RCK-862 folder and its name must have a maximum of 32 characters, including the extension (.ffg)

Note: The folder must contain a maximum of 32 firmware files.

19.6 Restore factory default:

Restores all parameters to the settings to factory defaults. Access path: Main Menu → 6. Restore Factory Default.



Note: Administrator access level is required to perform this procedure.

Note: To perform this procedure, the control status must be in OFF mode.

20.PARAMETER TABLE

1.1 Groups:

Settings menu related to groups. A group is a set of suction or discharge lines that have links (same refrigerator circuit).

Example: A Rack-type refrigeration system with two suction lines, one for frozen and one for colds, sharing the same discharge line forms a group composed of three pressure switches.

Function	Description	Minimum	Maximum	Standard	Unit
1.1.1	Initial delay	5	999	6	sec
1.1.2	Number of suction pressure switches	0	3	1	-
1.1.3	Number of discharge pressure switches	0	3	1	-
1.1.4	General time between compressor starts	0	60	0	sec
1.1.5	Suction 1 group	1	3	1	-
1.1.6	Suction 2 group	1	3	1	-
1.1.7	Suction 3 group	1	3	1	-
1.1.8	Group 1: Refrigerant fluid	0	36	0	-
1.1.9	Group 2: Refrigerant fluid	0	36	0	-
1.1.10	Group 3: Refrigerant fluid	0	36	0	-
1.1.11	Group 1: Economic setpoint input time	00:00	24:00 [off]	24:00 [off]	hh:mm
1.1.12	Group 1: Economic setpoint output time	00:00	24:00 [off]	24:00 [off]	hh:mm
1.1.13	Group 2: Economic setpoint input time	00:00	24:00 [off]	24:00 [off]	hh:mm
1.1.14	Group 2: Economic setpoint output time	00:00	24:00 [off]	24:00 [off]	hh:mm
1.1.15	Group 3: Economic setpoint input time	00:00	24:00 [off]	24:00 [off]	hh:mm
1.1.16	Group 3: Economic setpoint output time	00:00	24:00 [off]	24:00 [off]	hh:mm
1.1.17	Group 1: Night mode entry time	00:00	24:00 [off]	24:00 [off]	hh:mm
1.1.18	Group 1: Night mode exit time	00:00	24:00 [off]	24:00 [off]	hh:mm
1.1.19	Group 1: Night time limit of fans	30	100	100	%
1.1.20	Group 2: Night mode entry time	00:00	24:00 [off]	24:00 [off]	hh:mm
1.1.21	Group 2: Night mode exit time	00:00	24:00 [off]	24:00 [off]	hh:mm
1.1.22	Group 2: Nighttime limit of fans	30	100	100	%
1.1.23	Group 3: Night mode entry time	00:00	24:00 [off]	24:00 [off]	hh:mm
1.1.24	Group 3: Night mode exit time	00:00	24:00 [off]	24:00 [off]	hh:mm
1.1.25	Group 3: Nighttime limit of fans	30	100	100	%
1.1.26	Synchronization between suction 1 and suction 2	0	1	0	-
1.1.27	Synchronization between suction 1 and suction 3	0	1	0	-
1.1.28	Synchronization between suction 2 and suction 3	0	1	0	-

1.1.1 Initial Delay:

It is the time that the controller waits before enabling the pressure switches when the control is activated.

The discharge pressure switches are enabled after the configured time has elapsed.

The suction pressure switches are enabled according to the following logic:

After the initial delay time has elapsed, the pressure switch, with the lowest index, that is capable of being activated (pressure above the setpoint + step) will be enabled;

After the initial delay time has elapsed for the second time, the configured time will enable the next suitable pressure switch;

After the initial delay time has elapsed for the third time, the configured time will enable the last pressure switch.

If there are no suitable pressure switches after: the configured time has elapsed, it will be enabled in the sequence, suction 1, suction 2 and suction 3.

The same sequence applies to the individual pressure switches.

20.PARAMETER TABLE

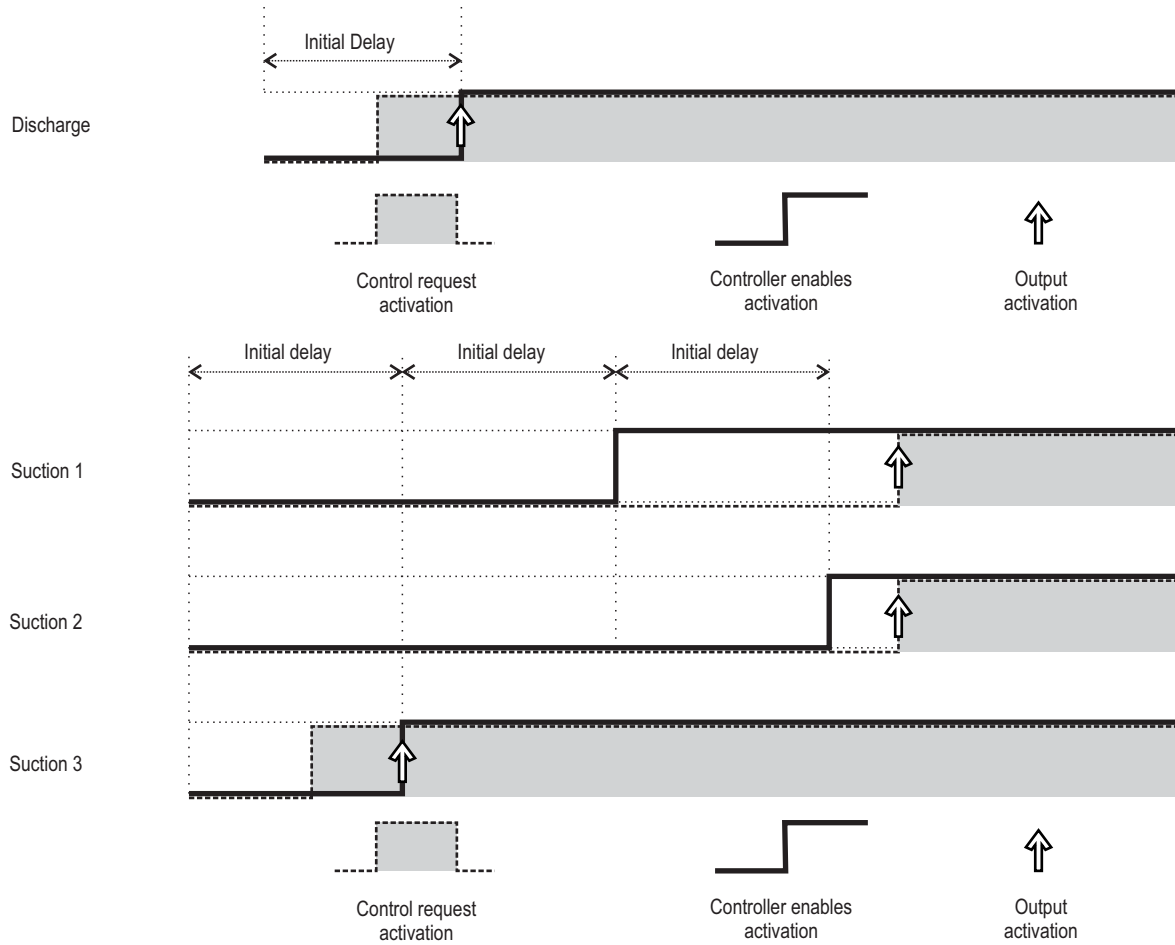

1.1.2 Number of suction pressure switches:

Defines the amount of suction pressure switches that are controlled by the **RCK-862_{plus}**.

1.1.3 Number of discharge pressure switches:

Defines the amount of discharge pressure switches that will be controlled by the **RCK-862_{plus}**.

1.1.4 General time between compressor starts:

Defines the time between compressor starts to prevent simultaneous activations. This applies to all compressors, regardless of the suction line.

1.1.5 to 1.1.7 Suction group x:

The suction pressure switches are linked with the control groups.

1.1.8 to 1.1.10 Group refrigerant fluid x:

Defines the refrigerant used in the group.

Refrigerant List:

0 = Custom	9 = R407F	18 = R507A	27 = R452B	36 = R1270
1 = R12	10 = R410A	19 = R513A	28 = R454A	
2 = R22	11 = R422A	20 = R600A	29 = R454B	
3 = R32	12 = R422D	21 = R717	30 = R454C	
4 = R134A	13 = R427A	22 = R744	31 = R455A	
5 = R290	14 = R441A	23 = R1234YF	32 = R457A	
6 = R404A	15 = R448A	24 = R1234ze(E)	33 = R508B	
7 = R407A	16 = R449A	25 = R23	34 = R515B	
8 = R407C	17 = R450A	26 = R452A	35 = R516A	

1.1.11 / 1.1.13 and 1.1.15 Group x Economic setpoint input time:

Defines the time when the setpoints of the pressure switches belonging to group x is changed to economic mode.

1.1.12 / 1.1.14 and 1.1.16 Group x Economic setpoint output time:

Defines the time when the setpoints of the pressure switches belonging to group x is changed to normal mode.

20.PARAMETER TABLE

1.1.17 Group 1 Night mode entry time:

Sets the time when unload 1 goes into capacity-limited night mode.

1.1.18 Group 1 Night mode exit time:

Sets the time when download 1 exits night mode.

1.1.19 Group 1 Night time limit of fans:

Sets the maximum discharge line capacity value during the night period.

1.1.20 Group 2 Night mode entry time:

Sets the time when flush 2 goes into capacity-limited night mode.

1.1.21 Group 2 Night mode exit time:

Sets the time when download 2 exits night mode.

1.1.22 Group 2 Night time limit of fans:

Sets the maximum discharge line capacity value during the night period.

1.1.23 Group 3 Night mode entry time:

Sets the time when flush 3 goes into capacity-limited night mode.

1.1.24 Group 3 Night mode exit time:

Sets the time when download 3 exits night mode.

1.1.25 Group 3 Night time limit of fans:

Sets the maximum discharge line capacity value during the night period.

1.1.26 Synchronization between suction 1 and suction 2:

Determines the synchronization between the two lines. Before starting line 1, the first compressor in line 2 is activated at minimum capacity and in case of an alarm in line 2, line 1 is switched off.

1.1.27 Synchronization between suction 1 and suction 3:

Determines the synchronization between the two lines. Before starting line 1, the first compressor in line 3 is activated at minimum capacity and in case of an alarm in line 3, the line is switched off.

1.1.28 Synchronization between suction 2 and suction 3:

Determines the synchronization between the two lines. Before starting line 2, the first compressor in line 3 is activated at minimum capacity and in case of an alarm in line 3, line 2 is switched off.

1.2 Suction:

Opens the list of suction pressure switches.

1.2.x Suction x:

List of parameters related to "x" suction pressure switch control. Where x represents suctions 1, 2 or 3.

Function	Description	Minimum	Maximum	Standard	Unit
1.2.x.1	Control mode	0	4	0	-
1.2.x.2	Control type	0	3	0	-
1.2.x.3	Pressure setpoint	-14,7 (-1,0)	31910,0 (220,0)	20,0 (1,4)	Psi (Bar)
1.2.x.4	Economic pressure setpoint	-14,7 (-1,0)	31910,0 (220,0)	30,0 (2,1)	Psi (Bar)
1.2.x.5	Hysteresis of On / Off compressors pressure	0	1600,0 (110,3)	6,0 (0,4)	Psi (Bar)
1.2.x.6	Hyst. of the Variable Capacity Compressor (VCC) pressure	0	1600,0 (110,3)	10,0 (0,7)	Psi (Bar)
1.2.x.7	Hysteresis of AP control mode pressure	0	1600,0 (110,3)	10,0 (0,7)	Psi (Bar)
1.2.x.8	Lower dead zone differential pressure	0	1600,0 (110,3)	0	Psi (Bar)
1.2.x.9	Upper dead zone differential pressure	0	1600,0 (110,3)	0	Psi (Bar)
1.2.x.10	Minimum pressure setpoint	-14,7 (-1,0)	31910,0 (220,0)	0	Psi (Bar)
1.2.x.11	Maximum pressure setpoint	-14,7 (-1,0)	31910,0 (220,0)	31910,0 (220,0)	Psi (Bar)
1.2.x.12	Temperature setpoint	-200 (-328,0)	200,0 (392,0)	0,0 (32,0)	°C (°F)
1.2.x.13	Economical temperature setpoint	-200 (-328,0)	200,0 (392,0)	0,0 (32,0)	°C (°F)
1.2.x.14	Hysteresis of compressors On / Off in temperature	0,0 (0,0)	200,0 (360,0)	10,0 (18,0)	°C (°F)
1.2.x.15	Variable capacity compressor hysteresis in temperature	0,0 (0,0)	200,0 (360,0)	10,0 (18,0)	°C (°F)
1.2.x.16	Hysteresis of AP control mode temperature	0,0 (0,0)	200,0 (360,0)	10,0 (18,0)	°C (°F)
1.2.x.17	Lower dead zone differential temperature	0,0 (0,0)	200,0 (360,0)	10,0 (18,0)	°C (°F)

20.PARAMETER TABLE

Function	Description	Minimum	Maximum	Standard	Unit
1.2.x.18	Upper dead zone differential temperature	0,0 (0,0)	200,0 (360,0)	0,0 (0,0)	°C (°F)
1.2.x.19	Minimum temperature setpoint	-200 (-328,0)	200,0 (392,0)	-50 (-58,0)	°C (°F)
1.2.x.20	Maximum temperature setpoint	-200 (-328,0)	200,0 (392,0)	200,0 (392,0)	°C (°F)
1.2.x.21	Integral time	60	1000 [Off]	1000 [Off]	sec
1.2.x.22	Critical pressure for shutdown	-14,8 (Off)	3191,0 (200,0)	-14,8 (Off)	Psi (Bar)
1.2.x.23	Low pressure for shutdown	-14,8 (Off)	3191,0 (200,0)	-14,8 (Off)	Psi (Bar)
1.2.x.24	Suction pressure sensor	0	1010	0	-
1.2.x.25	Backup pressure sensor	0	1010	0	-
1.2.x.26	Suction pressure sensor	0	1010	0	-
1.2.x.27	Secondary fluid inlet temperature sensor	0	1010	0	-
1.2.x.28	Reserve secondary fluid inlet temperature sensor	0	1010	0	-
1.2.x.29	Secondary fluid outlet temperature sensor	0	1010	0	-
1.2.x.30	Backup Secondary Fluid Outlet Temperature Sensor	0	1010	0	-
1.2.x.31	Number of compressors	1	6	1	-
1.2.x.32	Compressor 1 - Capacity	1	500	1	kW
1.2.x.33	Compressor 2 - Capacity	1	500	1	kW
1.2.x.34	Compressor 3 - Capacity	1	500	1	kW
1.2.x.35	Compressor 4 - Capacity	1	500	1	kW
1.2.x.36	Compressor 5 - Capacity	1	500	1	kW
1.2.x.37	Compressor 6 - Capacity	1	500	1	kW
1.2.x.38	Compressor 1 - Modulation	0	14	0	-
1.2.x.39	Compressor 2 - Modulation	0	4	0	-
1.2.x.40	Compressor 3 - Modulation	0	4	0	-
1.2.x.41	Compressor 4 - Modulation	0	4	0	-
1.2.x.42	Compressor 5 - Modulation	0	4	0	-
1.2.x.43	Compressor 6 - Modulation	0	4	0	-
1.2.x.44	Compressor 1 - Activation mode	0	2	0	-
1.2.x.45	Compressor 2 - Activation mode	0	2	0	-
1.2.x.46	Compressor 3 - Activation mode	0	2	0	-
1.2.x.47	Compressor 4 - Activation mode	0	2	0	-
1.2.x.48	Compressor 5 - Activation mode	0	2	0	-
1.2.x.49	Compressor 6 - Activation mode	0	2	0	-
1.2.x.50	Actuation sequence	0	1	0	-
1.2.x.51	Shut down sequence	0	1	0	-
1.2.x.52	Compressor 1 - Analog output	0	-	0	-
1.2.x.53	Compressor 1 - Main output	0	-	0	-
1.2.x.54	Compressor 1 - Auxiliary output 1	0	-	0	-
1.2.x.55	Compressor 1 - Auxiliary output 2	0	-	0	-
1.2.x.56	Compressor 1 - Auxiliary output 3	0	-	0	-
1.2.x.57	Compressor 1 - Auxiliary output 4	0	-	0	-
1.2.x.58	Compressor 2 - Main output	0	-	0	-
1.2.x.59	Compressor 2 - Auxiliary output 1	0	-	0	-
1.2.x.60	Compressor 2 - Auxiliary output 2	0	-	0	-
1.2.x.61	Compressor 2 - Auxiliary output 3	0	-	0	-
1.2.x.62	Compressor 3 - Main output	0	-	0	-
1.2.x.63	Compressor 3 - Auxiliary output 1	0	-	0	-
1.2.x.64	Compressor 3 - Auxiliary output 2	0	-	0	-
1.2.x.65	Compressor 3 - Auxiliary output 3	0	-	0	-
1.2.x.66	Compressor 4 - Main output	0	-	0	-
1.2.x.67	Compressor 4 - Auxiliary output 1	0	-	0	-
1.2.x.68	Compressor 4 - Auxiliary output 2	0	-	0	-
1.2.x.69	Compressor 4 - Auxiliary output 3	0	-	0	-

20.PARAMETER TABLE

Function	Description	Minimum	Maximum	Standard	Unit
1.2.x.70	Compressor 5 - Main output	0	-	0	-
1.2.x.71	Compressor 5 - Auxiliary output 1	0	-	0	-
1.2.x.72	Compressor 5 - Auxiliary output 2	0	-	0	-
1.2.x.73	Compressor 5 - Auxiliary output 3	0	-	0	-
1.2.x.74	Compressor 6 - Main output	0	-	0	-
1.2.x.75	Compressor 6 - Auxiliary output 1	0	-	0	-
1.2.x.76	Compressor 6 - Auxiliary output 2	0	-	0	-
1.2.x.77	Compressor 6 - Auxiliary output 3	0	-	0	-
1.2.x.78	Minimum time between compressor actuation	1 [off]	9999	5	sec
1.2.x.79	Minimum time between compressor shut down	1 [off]	9999	5	sec
1.2.x.80	Minimum time compressor on	1 [off]	9999	120	sec
1.2.x.81	Minimum time compressor off	1 [off]	9999	120	sec
1.2.x.82	Time between unloaders actuation	1 [off]	999	5	sec
1.2.x.83	Time between unloader shutdown	1 [off]	999	5	sec
1.2.x.84	VCC: Minimum Capacity	0	50	10	%
1.2.x.85	VCC: Maximum Capacity	0	100	100	%
1.2.x.86	VCC: Minimum Start-Up Capacity	0	100	30	%
1.2.x.87	VCC: Pre-Shutdown Capacity	0	100	30	%
1.2.x.88	VCC: Start-Up Capacity Time	0	999	30	sec
1.2.x.89	VCC: Pre-Shutdown Capacity Time	0	999	0	sec
1.2.x.90	VCC: Lower Validation Time	1	999	20	sec
1.2.x.91	VCC: Upper Validation Time	1	999	20	sec
1.2.x.92	VCC-Digital: Control Period	9 [Off]	120	9 [Off]	sec
1.2.x.93	VCC-Digital: Minimum Valve Activation Time	2	30	5	sec
1.2.x.94	VCC: Capacity to enter Lubrication Control	10	100	10	%
1.2.x.95	VCC: Capacity During Lubrication Control	10	100	50	%
1.2.x.96	VCC: Time to Enter Lubrication Control	0[off]	9999	120	sec
1.2.x.97	VCC: Time in Lubrication Control	10	9999	120	sec
1.2.x.98	VCC: Operating Variation Time	0[off]	999	0	sec
1.2.x.99	VCC-Analog: Start-Up Ramp Time	0[off]	999	0	sec
1.2.x.100	VCC-Analog: Shutdown Ramp Time	0[off]	999	0	sec
1.2.x.101	VCC: Pulsating Valve On Time	2	20	10	sec
1.2.x.102	VCC: Pulsating Valve Off Time	2	20	10	sec

1.2.x.1 Control mode:

Selection of compressor control mode. Available modes:

- 0 = Linear
- 1 = Rotation
- 2 = Dead zone
- 3 = Dead zone with rotation
- 4 = Progressive Algorithm (compressors of different capacity)



Note: More information about the control modes in the item 15.4.

1.2.x.2 Control type:

Compressor control can be performed by pressure or temperature. In pressure control, the pressure sensor reading, the pressure setpoint and pressure hysteresis will be considered. In the control by saturation temperature, the temperature value resulting from the conversion of the pressure value into the temperature of the corresponding refrigerant will be respective. In this case it uses the temperature setpoint and temperature hysteresis. In the secondary fluid temperature control, the value of a temperature sensor will be considered. (Ex: input or output of a heat exchanger). In this case it uses the temperature setpoint and temperature hysteresis.

- 0 = Pressure
- 1 = Saturation temperature
- 2 = Secondary fluid inlet temperature (FS)
- 3 = Secondary fluid outlet temperature (FS)

1.2.x.3 Pressure setpoint:

Pressure value for suction control where the system shuts down all compressors.

20.PARAMETER TABLE

1.2.x.4 Economic pressure setpoint:

Alternative pressure setpoint value, generally higher than the pressure setpoint (1.2.x.3).

1.2.x.5 Hysteresis of On / Off compressors pressure:

It is the pressure range for controlling the On / Off compressors with or without unloaders. This pressure value is related to the setpoint that defines the actuation points for each compressor (actuation interval = setpoint + hysteresis).

Note: This parameter is not used in the Progressive Algorithm control mode.

1.2.x.6 Hysteresis of the Variable Capacity Compressor (VCC) pressure:

It is the pressure range for controlling Variable Capacity Compressors (VCC). The compressor modulation is done within this range relative to the setpoint.

Note: This parameter is valid only for Linear and Rotation control modes.

1.2.x.7 Hysteresis of AP Control Mode pressure:

It is the pressure range that corresponds to all compressors actuated (On / Off and VCC). The reference values for actuation are calculated from the capacity of each compressor.

Note: This parameter is used in the Progressive Algorithm control mode.

1.2.x.8 Lower dead zone differential pressure:

Pressure differential below the setpoint that allows the compressors to be shut down. Used in the Dead zone and Dean Zone with rotation Control modes.

1.2.x.9 Upper dead zone differential pressure:

Pressure differential above the setpoint that allows the compressors to be actuated. Used in the Dead zone and Dead zone with rotation Control modes.

1.2.x.10 Minimum pressure setpoint:

Lowest possible value for adjusting the setpoint. The purpose is to prevent unreasonably low pressures from being regulated by mistake from the normal and economic setpoint.

1.2.x.11 Maximum pressure setpoint:

Highest possible value for setpoint adjustment. The purpose is to prevent unreasonably high pressures from being regulated by mistake from the normal and economic setpoint.

1.2.x.12 Temperature setpoint:

Temperature value for suction control at which the system turns off all compressors.

1.2.x.13 Economical temperature setpoint:

Alternate temperature setpoint value, normally greater than temperature setpoint (1.2.x.12).

1.2.x.14 Hysteresis of On/Off compressors in temperature:

It is the temperature range for controlling On/Off compressors with or without unloaders. This temperature value is relative to the setpoint that defines the trigger points for each compressor (trigger range = setpoint + hysteresis).

Note: This parameter is not used in Progressive Algorithm Control Mode.

1.2.x.15 Variable Capacity Compressor Hysteresis in temperature:

It is the temperature range for controlling Variable Capacity Compressors (VCC). Compressor modulation is done within this range relative to the setpoint.

Note: This parameter is only valid for Linear and Rotation Control Modes.

1.2.x.16 Hysteresis of AP Control Mode temperature:

It is the pressure range that corresponds to all compressors actuated (On / Off and VCC). The reference values for actuation are calculated from the capacity of each compressor.

Note: This parameter is used in the Progressive Algorithm control mode.

1.2.x.17 Lower dead zone differential temperature:

Pressure differential below the setpoint that allows the compressors to be shut down. Used in the Dead zone and Dean Zone with rotation Control modes.

1.2.x.18 Upper dead zone differential temperature:

Pressure differential above the setpoint that allows the compressors to be actuated. Used in the Dead zone and Dead zone with rotation Control modes.

20.PARAMETER TABLE

1.2.x.19 Minimum temperature setpoint:

Lowest possible value for adjusting the setpoint. The purpose is to prevent unreasonably low pressures from being regulated by mistake from the normal and economic setpoint.

1.2.x.20 Maximum temperature setpoint::

Highest possible value for setpoint adjustment. The purpose is to prevent unreasonably high pressures from being regulated by mistake from the normal and economic setpoint.

1.2.x.21 Integral time:

When set to a value greater than Off, it enables the Proportional / Integral (PI) control for the compressors. The value of this parameter corresponds to the time in which 100% of the control error is accumulated (suction pressure - setpoint). This value must be configured according to the characteristics of each installation. The higher the value, the slower and more stable the system's behavior. The lower the configured value, the faster and more oscillatory the behavior is.

1.2.x.22 Critical pressure for shutdown:

Limit pressure value for operation. Below this value, all compressors are turned off (it is recommended to use this function as a safety measure when controlling by temperature). Note: This function is only considered if both 1.2.x.22 and 1.2.x.23 are different from Off.

1.2.x.23 Low pressure for shutdown:

Limit pressure value for operation. Below this value, the activated capacity of the line is proportionally limited with the reduction of pressure until total shutdown when the pressure reaches the value of 1.2.x.22 (it is recommended to use this function as a safety measure when the control is done by temperature). Note: This function is only considered if both 1.2.x.22 and 1.2.x.23 are different from Off.

1.2.x.24 Suction pressure sensor:

Defines the pressure sensor used for the suction control.

1.2.x.25 Backup pressure sensor:

Defines the backup pressure sensor used for the suction control.

When configured, this sensor automatically takes the suction pressure reading.

1.2.x.26 Suction temperature sensor:

Defines the suction temperature sensor (refrigerant).

When configured, it allows monitoring of the suction line overheating.

1.2.x.27 Secondary fluid inlet temperature sensor:

Defines the sensor used to measure the temperature of a secondary fluid for control or monitoring.

1.2.x.28 Reserve secondary fluid inlet temperature sensor:

Defines the backup sensor used to measure the temperature of a secondary fluid for control or monitoring.

1.2.x.29 Secondary fluid outlet temperature sensor:

Defines the sensor used to measure the temperature of a secondary fluid for control or monitoring.

1.2.x.30 Backup secondary fluid outlet temperature sensor:

Defines the backup sensor used to measure the temperature of a secondary fluid for control or monitoring.

1.2.x.31 Number of compressors:

Number of compressors used to control suction.



Note: The sensors of the expansion modules will be available after configuring the expansions in menu 4.

1.2.x.32 to 1.2.x.37 Compressor 01-06 capacity:

Compressor capacity in kW. This parameter is used in Control mode by progressive algorithm.

1.2.x.38 to 1.2.x.43 Compressor x modulation:

Configures the type of compressor actuation.

On/Off: On-off compressor that uses only one digital output (relay) for its actuation.

On/Off 50 | 100: Compressor that used two digital outputs (relay) for its actuation. The main output, and an auxiliary output in which each output corresponds to 50% of the compressor capacity.

On/Off 33 | 66 | 100: Compressor that used three digital outputs (relay) for its actuation. The main output and two auxiliary outputs in which each output corresponds to 33% of the compressor capacity.

On/Off 50 | 75 | 100: Compressor that uses three digital outputs (relay) for its actuation. The main output corresponds to 50% of the compressor capacity and each of the two auxiliary outputs corresponds to 25% of the compressor capacity.

20.PARAMETER TABLE

On/Off 25 | 50 | 75 | 100: Compressor that uses four digital outputs (relay) for its actuation. The main output corresponds to 25% of the compressor capacity and each of the three auxiliary outputs corresponds to 25% of the compressor capacity.

VCC - Analog: Variable capacity compressor that uses an analog output (0-10V) for its control (available in compressor 01 of each suction line). Optionally, it is possible to configure a digital output with start / stop function, in the parameter "compressor 1 main output". **Application example:** Compressors using frequency inverters.

VCC - Digital 10-100 3V: Compressor of variable capacity that uses one main output (relay) for its actuation plus three auxiliary outputs (SSR) for capacity modulation. The compressor's instantaneous capacity is 0% with the three auxiliary outputs on, 33% with two outputs on, 66% with an auxiliary output on and 100% with the three auxiliary outputs off. **Application example:** Bitzer CR11 compressors.

VCC - Digital 33-100 1V: Variable capacity compressor that uses a main output (relay) for its actuation plus an auxiliary output (SSR) for capacity modulation. The compressor's instantaneous capacity is 33% with the auxiliary output on and 100% with the auxiliary output off.

VCC - Digital 33-100 2V: Variable capacity compressor that uses a main output (relay) for its activation plus two auxiliary outputs (SSR) for capacity modulation. Compressor instantaneous capacity is 33% with two auxiliary outputs connected, 66% with one output auxiliary on and 100% with both auxiliary outputs off.

VCC - Digital 50-100 1V: Compressor of variable capacity that uses a main output (relay) for its actuation plus an auxiliary output (SSR) for capacity modulation. The compressor's instantaneous capacity is 50% with the auxiliary output on and 100% with the auxiliary output off.

VCC - Digital 10-100 2V_B: Variable capacity compressor that uses a main output (relay) for its activation, and an auxiliary output (SSR) for modulation at 50% of the capacity (aux output 1) and an unloader type auxiliary output at 50% of the capacity (aux output two).

VCC - Digital 10-100 3V_B: Variable capacity compressor that uses a main output (relay) for its activation, a fast auxiliary output (SSR) for modulation at 33% of the capacity (aux output 1) and two unloader type auxiliary outputs at 33% of the capacity each (outputs auxiliaries 2 and 3).

VCC - 25 | 50 | 75 | 100 | S: Variable Capacity Compressor of the screw type with a sliding valve for capacity control. Auxiliary output 1 is responsible for positioning the valve at 75% capacity, auxiliary output 2 is responsible for positioning the valve at 50%, and auxiliary output 3 is responsible for positioning the valve at 25% and enabling startup relief. Auxiliary output 4 is kept pulsating with on and off time intervals configured in functions 1.2.x.101 and 1.2.x.102.

1.2.x.44 to 1.2.x.49 Compressor 01-06 Activation mode:

Parameter that determines the preferred actuation of the compressor outputs that use auxiliary digital outputs. For more information on the unloader actuation modes (auxiliary outputs) see section: 14.2 Compressor Modulation.

0 = Incremental Mode 1 = Unloader Mode 2 = Selective Mode

1.2.x.50 Actuation sequence:

Defines the sequence in which compressors and unloaders are actuated.

0 - PPuu (Actuates compressors first and then unloaders);

1 - PuPu (Actuates a compressor completely before starting another compressor).

1.2.x.51 Shutdown sequence:

Defines the sequence in which compressors and loaders are shut down.

0 - PPuu (shut down unloaders first and then compressors);

1 - PuPu (shut down a compressor completely before starting another compressor).

1.2.x.52 Compressor 01 analog output:

Analog output address of compressor 01. This parameter is available if the compressor modulation is VCC-Analog.

0 = Not configured 1 = A1 2 = A2

1.2.x.53, 58, 62, 66, 70, 74 Compressor 01-06 main output:

Compressor xx digital output address.

1.2.x.54, 59, 63, 67, 71, 75 Compressor 01-06 auxiliary output 01:

Compressor xx auxiliary output 01 address.

1.2.x.55, 60, 64, 68, 72, 76 Compressor 01-06 auxiliary output 02:

Compressor xx auxiliary output 02 address.

1.2.x.56, 61, 65, 69, 73, 77 Compressor 01-06 auxiliary output 03:

Compressor xx auxiliary output 03 address.

Digital output address:

0 = Not configured

1 = Base - O1

2 = Base - O2

3 = Base - O3

4 = Base - O4

5 = Base - O5

6 = Base - O6

Note: If a currently used output is selected, it will be replaced.

Note: For information on the inputs and outputs of the expansions refer to topic 19.4.

20.PARAMETER TABLE

1.2.x.57 Compressor 01 auxiliary output 04:

Compressor xx auxiliary output 04 address.

1.2.x.78 Time between compressor actuation:

The function applies to the main control outputs of the compressors and is the minimum time between two actuations of the main digital outputs in the suction lines. This time value ensures that no simultaneous actuation of compressors will occur, preventing surges in the supply network and excessive fluctuations in the control pressure.

1.2.x.79 Time between compressor shut down:

The function applies to the main control outputs of the compressors and is the minimum time between two shutdowns of the main digital outputs on the suction. This time value guarantees that simultaneous compressor shutdowns will not occur, avoiding electrical variations in the supply network and excessive fluctuations in the control pressure.

1.2.x.80 Minimum time compressor on:

It is the minimum time that the compressor will remain on, that is, time between the last start and the next stop.

1.2.x.81 Minimum time compressor off:

It is the minimum time that the compressor will remain off, that is, the time between the last stop and the next start.

1.2.x.82 Time between unloaders actuations:

It is the time interval between the actuation of two auxiliary digital outputs (unloaders) of the same compressor.

1.2.x.83 Time between unloader shutdown:

It is the time interval between shutting down two auxiliary digital outputs (unloaders) from the same compressor.

1.2.x.84 VCC - Minimum capacity:

Defines the minimum operating capacity of the compressor.

Note: The compressor manufacturer must be consulted regarding the minimum allowable capacity. Operating below the permitted capacity may result in excessive heating and poor oil circulation.

1.2.x.85 VCC - Maximum capacity:

Defines the maximum operating capacity of the compressor, limiting its operation to the configured value.

1.2.x.86 VCC - Minimum start-up capacity:

Specifies the capacity value during the compressor start-up time, as well as the demand value required for its start-up.

1.2.x.87 VCC - Pre-shutdown capacity time:

Compressor capacity value during the pre-shutdown time.

1.2.x.88 VCC - Start-up capacity time:

The time the Variable Capacity Compressor remains in the start condition.

VCC-Analog compressors assume the capacity value configured in "VCC - Minimum Start-Up Capacity" (1.2.x.86).

VCC-Digital compressors keep the auxiliary outputs energized, causing the compressor to operate without fluid compression.

VCC-25 | 50 | 75 | 100 | S, screw-type compressors with a sliding valve, only auxiliary output 3 remains active, acting as the Start Unloader (SU).

1.2.x.89 VCC - Pre-shutdown capacity time:

Defines the time the compressor remains operating at pre-shutdown capacity before it is fully turned off.

1.2.x.90 VCC - Lower validation time:

This time is a validation of the need to deactivate the next compression stage and prevent unnecessary shutdowns. When the VCC compressor reaches the minimum value, where control would immediately deactivate or activate the next compression stage (On/Off compressor or unloaders valve), the control waits for this time to validate the transition and take the next action.

1.2.x.91 VCC - Upper validation time:

This time is a validation of the need to activate the next compression stage and prevent unnecessary activations. When the VCC compressor reaches the maximum value, where control would immediately activate the next compression stage (On/Off compressor or unloaders valve), the control waits for this time to validate the transition and take the next action.

1.2.x.92 VCC - Digital / Control period:

Configures the modulation signal period for the Variable Capacity Digital Compressor. When set to the default value (auto), the period is calculated automatically by the control algorithm.

20.PARAMETER TABLE

1.2.x.93 VCC-Digital / Minimum valve activation time:

Configures the minimum time the valves of VCC-Digital compressors must remain on or off during modulation.

1.2.x.94 VCC - Capacity to enter lubrication control:

Defines the capacity value below which the lubrication control routine is initiated.

1.2.x.95 VCC - Capacity during lubrication control:

Defines the compressor capacity value during the lubrication control routine.

1.2.x.96 VCC - Time to enter lubrication control:

Defines the time the compressor must operate below the capacity defined in 1.2.x.94 before starting the lubrication routine.

1.2.x.97 VCC - Time in Lubrication control:

Defines lubrication routine duration. Time the compressor remains at the capacity value configured in 1.2.x.95.

1.2.x.98 VCC - Operating variation time:

Defines the rate of variation in compressor capacity. It specifies the time required to transition from 0% to 100% or 100% to 0% during operation.

1.2.x.99 VCC-Analog / Start-up ramp time:

Defines start-up ramp time. Time required to vary from 0 to the startup value (1.2.x.86).

Notes: The time in startup capacity (1.2.x.88) is counted only after the capacity reaches the startup value.

1.2.x.100 VCC-Analog / Shutdown ramp time:

Defines the time required to vary from the VCC - Pre-Shutdown Capacity (1.2.x.87) to 0. In case of shutdown due to alarm or intentional shutdown, it is considered as the time to vary from 100% to 0.

1.2.x.101 VCC - Pulsating valve on time:

The time interval during which auxiliary output 4 remains on when the compressor is configured with VCC-25 | 50 | 75 | 100 | S modulation.

1.2.x.102 VCC - Pulsating valve off time:

The time interval during which auxiliary output 4 remains off when the compressor is configured with VCC-25 | 50 | 75 | 100 | S modulation

1.3 Discharge:

Opens the list of discharge pressure switches.

1.3.x Discharge x:

List of parameters related to the control of the discharge pressure switch "x". Where x represents discharges 1, 2 or 3.

Function	Description	Minimum	Maximum	Standard	Unit
1.3.x.1	Control mode	0	3	0	-
1.3.x.2	Control type	0	2	0	-
1.3.x.3	Pressure setpoint	0	3191,0 (220,0)	100,0 (6,9)	Psi (Bar)
1.3.x.4	Economic pressure setpoint	0	3191,0 (220,0)	80,0 (5,5)	Psi (Bar)
1.3.x.5	Hysteresis of digital outputs	0	1600,0 (110,3)	10,0 (0,7)	Psi (Bar)
1.3.x.6	Hysteresis of analog output	0	1600,0 (110,3)	10,0 (0,7)	Psi (Bar)
1.3.x.7	Lower dead zone differential	0	1600,0 (110,3)	0	Psi (Bar)
1.3.x.8	Upper dead zone differential	0	1600,0 (110,3)	0	Psi (Bar)
1.3.x.9	Minimum pressure setpoint	0	3191,0 (220,0)	0	Psi (Bar)
1.3.x.10	Maximum pressure setpoint	0	3191,0 (220,0)	3191,0 (220,0)	Psi (Bar)
1.3.x.11	Temperature setpoint	0	200,0 (392,0)	40 (104,0)	°C (F)
1.3.x.12	Economic temperature setpoint	0	200,0 (392,0)	50 (122,0)	°C (F)
1.3.x.13	Digital output hysteresis	0	200,0 (392,0)	10 (18,0)	°C (F)
1.3.x.14	Analog output hysteresis	0	200,0 (392,0)	10 (18,0)	°C (F)
1.3.x.15	Lower dead zone limit	0	200,0 (392,0)	0 (0)	°C (F)
1.3.x.16	Upper dead zone limit	0 (0)	200,0 (392,0)	0 (0)	°C (F)
1.3.x.17	Minimum temperature setpoint	0 (32)	200,0 (392,0)	0 (32)	°C (F)
1.3.x.18	Maximum temperature setpoint	0 (32)	200,0 (392,0)	200 (392,0)	°C (F)
1.3.x.19	Discharge pressure sensor	0	-	0	-
1.3.x.20	Backup pressure sensor	0	-	0	-
1.3.x.21	Liquid line temperature sensor	0	-	0	-
1.3.x.22	Reserve liquid line temperature sensor	0	-	0	-
1.3.x.23	External temperature sensor (TBS)	0	-	0	-
1.3.x.24	Number of fans	0	6	1	-
1.3.x.25	Fan 1 Modulation	0	1	0	-

20.PARAMETER TABLE

Function	Description	Minimum	Maximum	Standard	Unit
1.3.x.26	Fan 1 minimum capacity	0	100	10	%
1.3.x.27	Fan 1 start-up capacity	0	100	10	%
1.3.x.28	Fan 1 maximum capacity	0	100	100	%
1.3.x.29	Fan 1 Analog output	0	-	0	-
1.3.x.30	Fan 1 Digital output	0	-	0	-
1.3.x.31	Fan 2 Digital output	0	-	0	-
1.3.x.32	Fan 3 Digital output	0	-	0	-
1.3.x.33	Fan 4 Digital output	0	-	0	-
1.3.x.34	Fan 5 Digital output	0	-	0	-
1.3.x.35	Fan 6 Digital output	0	-	0	-
1.3.x.36	Minimum time between actuations	1	9999	5	sec
1.3.x.37	Minimum time between shutdowns	1	9999	5	sec
1.3.x.38	Minimum time fan on	1	9999	30	sec
1.3.x.39	Minimum time fan off	1	9999	30	sec
1.3.x.40	Analog output start time	1	999	10	sec
1.3.x.41	Analog output validation time	1	999	20	sec
1.3.x.42	Integral time	60	1000 [Off]	1000 [Off]	sec

1.3.x.1 Control Mode:

Selection of the fan control mode. Available modes:

- 0 = Linear
- 1 = Rotation
- 2 = Dead zone
- 3 = Dead zone with rotation

1.3.x.2 Control type:

The discharge control can be carried out by pressure or temperature.

In pressure control, the pressure sensor, pressure setpoint and pressure hysteresis will be considered.

Temperature control will consider the temperature sensor, temperature setpoint and temperature hysteresis

- 0 = Pressure
- 1 = Temperature saturation
- 2 = Liquid line temperature

1.3.x.3 Pressure setpoint:

Pressure value for controlling the discharge in which the system shuts down all fans.

1.3.x.4 Economic pressure setpoint:

Alternative pressure setpoint value, usually less than the pressure setpoint (1.3.x.3).

1.3.x.5 Hysteresis of digital outputs:

It is pressure range for controlling the fans linked with the digital outputs. This pressure value is related to the setpoint that defines the actuation points for each fan (activation interval = setpoint + hysteresis).

1.3.x.6 Hysteresis of analog output:

It is pressure range for controlling the fan linked with the analog output. The modulation of the analog output is within this range related to the setpoint. This parameter is valid only for Linear and Rotation control modes.

20.PARAMETER TABLE

1.3.x.7 Lower dead zone differential:

Pressure differential, below the setpoint that allows the compressors to be shut off. Used in the Dead zone and Dead zone with rotation control modes.

1.3.x.8 Upper dead zone differential:

Pressure differential, above the setpoint that allows the compressors to be actuated. Used in the Dead zone and Dead zone with rotation control modes.

1.3.x.9 Minimum pressure setpoint:

Lowest possible value for setpoint adjustment. The purpose is to prevent unreasonably low pressures from being regulated by mistake from the normal and economic setpoint.

1.3.x.10 Maximum pressure setpoint:

Highest possible value for setpoint adjustment. The purpose is to prevent unreasonably high pressures from being regulated by mistake from the normal and economic setpoint.

1.3.x.11 Temperature setpoint:

Temperature value for controlling the discharge in which the system shuts off all fans.

1.3.x.12 Economic temperature setpoint:

Alternative temperature setpoint value, usually lower than the temperature setpoint (1.3.x.11).

1.3.x.13 Digital output Hysteresis:

It is the temperature range for controlling the fans linked with the digital outputs. This pressure value is related to the setpoint that defines the actuation points for each fan (actuation interval = setpoint + hysteresis).

1.3.x.14 Analog output hysteresis:

It is the temperature range for controlling the fan linked with the analog output. The modulation of the analog output is within this range related to the setpoint. This parameter is valid only for Linear and Rotation control modes.

1.3.x.15 Lower dead zone limit:

Lower limit whose purpose is to avoid that, by mistake, excessively low temperatures are regulated from the normal and economic setpoint.

1.3.x.16 Upper dead zone limit:

Upper limit whose purpose is to avoid that, by mistake, excessively high temperatures are regulated from the normal and economic setpoint.

1.3.x.17 Minimum temperature setpoint:

Lowest possible value for setpoint adjustment. The purpose is to avoid that, by mistake, excessively low temperatures are set from the normal and economic setpoint.

1.3.x.18 Maximum temperature setpoint:

Highest possible value for setpoint adjustment. The purpose is to avoid that, by mistake, excessively high temperatures are set from the normal and economic setpoint.

1.3.x.19 Discharge pressure sensor:

Defines the pressure sensor used to control the discharge.

1.3.x.20 Backup pressure sensor:

Defines the backup pressure sensor used to control the discharge.
When configured, this sensor automatically takes the discharge pressure reading.

1.3.x.21 Liquid line temperature sensor:

Liquid line temperature sensor address.
When configured, it allows monitoring of the discharge line overheating.

1.3.x.22 Reserve liquid line temperature :

Address of the reserve liquid line temperature sensor.
When configured, this sensor automatically takes the discharge of the liquid line sensor.

1.3.x.23 External temperature sensor :

Defines the dry air bulb temperature sensor.

1.3.x.24 Number of fans:

Number of fans used to control the discharge.

Sensor options:
0 = No configured
1 = Base - S1
2 = Base - S2
3 = Base - S3
4 = Base - S4
5 = Base - S5
6 = Base - S6



Note: The sensors present in the expansion modules will be listed in menu 4 after their configuration.

20.PARAMETER TABLE

1.3.x.25 Fan 1 Modulation:

Fan 1 modulation type is selected: ON/OFF (digital output) or INVERTER (analog output). It is possible to configure an output with start / stop function to operate together with the analog. To do this, just configure the "digital output of fan 1".

- 0 = No modulation
- 1 = Inverter

1.3.x.26 Fan 1 Minimum Capacity:

Minimum capacity value during fan operation.

1.3.x.27 Fan 1 Start-up Capacity:

Minimum capacity value at which the fan can be started.

1.3.x.28 Fan 1 Maximum Capacity:

Maximum operating capacity value.

1.3.x.29 Fan 1 Analog output:

Analog output address for fan 1 inverter.

- 0 = Not configured
- 1 = Base - A1
- 2 = Base - A2

1.3.x.30 to 1.3.x.35 Fan 01 to 06 Digital output:

Fan digital output address 1 to 6.

- 0 = Not configured
- 1 = Base - O1
- 2 = Base - O2
- 3 = Base - O3
- 4 = Base - O4
- 5 = Base - O5
- 6 = Base - O6



Note: The outputs present in the expansion modules will be listed in menu 4 after their configuration.

1.3.x.36 Minimum time between actuations:

The function applies to the main control outputs of the fans and is the minimum time between two actuations of the main digital outputs at discharge. This time guarantees that simultaneous fan actuations will not occur, preventing surges in the supply network and excessive fluctuations in the control variable.

1.3.x.37 Minimum time between shutdowns:

The function applies to the main control outputs of the fans and is the minimum time between two shutdowns of the main digital outputs. This time ensures that simultaneous fan shutdowns will not occur, preventing electrical surges in the supply network and excessive fluctuations in the control pressure.

1.3.x.38 Minimum time fan on:

It is the minimum time the fan will remain on, that is, the time between the last start and the next stop.

1.3.x.39 Minimum time fan off:

It is the minimum time that the fan will remain off, that is, the time between the last start and the next stop.

1.3.x.40 Analog output start time:

It is the time that the analog output remains at the starting value.

1.3.x.41 Analog output validation time:

This time is a validation of the need to actuate or shutdown a next ventilation stage and avoid unnecessary fan actuation or shutdown. When reaching the minimum or maximum value, where the control would immediately shut down or actuate a next fan, the control will wait for this time to validate the transition and take the next action.

1.3.x.42 Integral time:

When configured, it enables the Proportional / Integral (PI) control of the fans. The value of this parameter corresponds to the time in which 100% of the control error (hysteresis-setpoint) is accumulated. This value must be configured according to the characteristics of each system. The higher the value, the slower and more stable the system's behavior. The lower the configured value, the faster and more oscillatory the behavior is.

20.PARAMETER TABLE

1.4 Alarms:

Parameters related to alarm settings.

1.4.1 Alarm settings:

Function	Description	Minimum	Maximum	Standard	Unit
1.4.1.1	Pressure alarm validation time	0	9999	5	sec
1.4.1.2	Temperature alarm validation time	0	9999	5	sec
1.4.1.3	Other alarms validation time	0	9999	5	sec
1.4.1.4	Alarm inhibition time	0	9999	5	sec
1.4.1.5	Difference between pressure sensors	0 [Off]	3191,0 (220,0)	0 [Off]	Psi (bar)
1.4.1.6	Difference between temperature sensors	0 [Off]	200,0 (360,0)	0 [Off]	°C (°F)

1.4.1.1 Pressure alarm validation time:

It is the time between when the controller identifies a pressure alarm condition and its indication. This considers alarms related to pressure readings.

1.4.1.2 Temperature alarm validation time:

It is the time between when the controller identifies a temperature alarm condition and its indication. This considers alarms related to temperature readings.

1.4.1.3 Other alarms validation time:

It is the time between when the controller identifies an alarm condition and its indication. This considers cases not related to pressure and temperature.

1.4.1.4 Alarm inhibition time:

It is the time during which alarms remain inhibited after energization, even if alarm conditions are present.

1.4.1.5 Difference between pressure sensors:

Difference between main and backup pressure sensor readings to generate alarm.

1.4.1.6 Difference between temperature sensors:

Difference between main and backup temperature sensor readings to generate alarm.

1.4.2 Suction alarms:

Alarms are assigned separately for each suction pressure switch. In this list, select the suction to which you want to configure the alarms.

1.4.2.x Suction alarms:

If configured with the OFF parameter, alarms are not enabled.

The letter "x" represents suctions 1, 2 and 3.

Function	Description	Minimum	Maximum	Standard	Unit
1.4.2.x.1	Low pressure	-14,8 [off] (-1,1)	3191,0 (220,0)	-14,8 [off] (-1,1)	Psi (Bar)
1.4.2.x.2	High pressure	-14,7 (-1,0)	3191,1 [off] (220,1)	3191,1 [off] (220,1)	Psi (Bar)
1.4.2.x.3	Hysteresis of pressure alarms	1,0 (0,1)	1600,0 (110,3)	1,0 (0,1)	Psi (Bar)
1.4.2.x.4	Low saturation temperature	-200,1 [off] (-328,2)	200,0 (392,0)	-200,1 [off] (-328,2)	°C (°F)
1.4.2.x.5	High saturation temperature	-200,0 (-328,0)	200,1 [off] (392,2)	200,1 [off] (392,2)	°C (°F)
1.4.2.x.6	Saturation Temperature Alarm Hysteresis	0,3 (0,5)	200,0 (360,0)	5,0 (9,0)	°C (F)
1.4.2.x.7	Low secondary fluid inlet temperature	-50,1 [off] (-58,2)	200,0 (58,6)	-50,1 [off] (-58,2)	°C (°F)
1.4.2.x.8	High secondary fluid inlet temperature	-50,0 (-58,0)	200,1 [off] (392,2)	200,1 [off] (392,2)	°C (°F)
1.4.2.x.9	Low secondary fluid outlet temperature	-50,1 [off] (-58,2)	200,0 (58,6)	-50,1 [off] (-58,2)	°C (°F)
1.4.2.x.10	High secondary fluid outlet temperature	-50,0 (-58,0)	200,1 [off] (392,2)	200,1 [off] (392,2)	°C (°F)
1.4.2.x.11	Secondary fluid alarm hysteresis	0,3 (0,5)	200,0 (360,0)	5,0 (9,0)	°C (F)
1.4.2.x.12	Critical overheating	-0,1 [off] (-0,2)	50,0 (90,0)	-0,1 [off] (-0,2)	°C (F)
1.4.2.x.13	Low overheating	-0,1 [off] (-0,2)	50,0 (90,0)	-0,1 [off] (-0,2)	°C (F)
1.4.2.x.14	High overheating	0,0	50,1 [off] (90,2)	50,1 [off] (90,2)	°C (F)
1.4.2.x.15	Superheating Alarm Hysteresis	0,3 (0,5)	200,0 (360,0)	5,0 (9,0)	°C (F)

1.4.2.x.1 Low pressure:

Enables the alarm when the pressure is lower than the configured value.

1.4.2.x.2 High pressure:

Enables the alarm when the pressure is higher than the configured value.

20.PARAMETER TABLE

1.4.2.x.3 Hysteresis of pressure alarms:

It is pressure difference to get out of the alarm situation.

1.4.2.x.4 Low saturation temperature:

Enables the alarm when the temperature is higher than the configured value. Difference between temperature sensors.

1.4.2.x.5 High saturation temperature:

Enables the alarm when the temperature is lower than the configured value.

1.4.2.x.6 Saturation temperature alarm hysteresis:

It is temperature difference required to exit the alarm condition

1.4.2.x.7 Low secondary fluid inlet temperature:

Enables the alarm when the superheat is greater than the configured value.

1.4.2.x.8 High secondary fluid inlet temperature:

Enables the alarm when the pressure is lower than the configured value.

1.4.2.x.9 Low secondary fluid outlet temperature:

Enables the alarm when the pressure is greater than the configured value.

1.4.2.x.10 High secondary fluid outlet temperature:

Enables the alarm when the pressure is lower than the configured value.

1.4.2.x.11 Secondary fluid alarm hysteresis:

It is temperature difference required to exit the alarm condition.

1.4.2.x.12 Critical overheating:

Enables the alarm when the temperature is lower than the configured value. This value is usually lower than the low overheating value (1.4.2.x.13).

1.4.2.x.13 Low overheating:

Enables the alarm when the temperature is lower than the configured value.

1.4.2.x.14 High overheating:

Enables the alarm when the overheating is higher than the configured value.

1.4.2.x.15 Superheating alarm hysteresis:

It is temperature change required to exit the alarm condition.

1.4.3 Discharge alarms:

1.4.3.x Discharge alarms - discharge 1 to 3

The letter x represents discharges 1, 2 and 3.

Function	Description	Minimum	Maximum	Standard	Unit
1.4.3.x.1	Low pressure	-14,8 [off] (-1,1)	3191,0 (220,0)	-14,8 [off] (-1,1)	Psi (Bar)
1.4.3.x.2	High pressure	-14,7 (-1,0)	3191,1 [off] (220,1)	3191,1 [off] (200,1)	Psi (Bar)
1.4.3.x.3	Critical high pressure	-14,7 (-1,0)	3191,1 [off] (220,1)	3191,1 [off] (220,1)	Psi (Bar)
1.4.3.x.4	Hysteresis of pressure alarms	1,0 (0,1)	1600,0 (110,3)	1,0 (0,1)	Psi (Bar)
1.4.3.x.5	Low saturation temperature	-50,1 [off] (-58,2)	200,0 (392,0)	-50,1 [off] (-58,2)	°C (F)
1.4.3.x.6	High saturation temperature	-50,0 (-58,0)	200,1 (392,2)	200,1 [off] (392,2)	°C (F)
1.4.3.x.7	Critical high saturation temperature	-50,0 (-58,0)	200,1 [off] (392,2)	200,1 [off] (392,2)	°C (F)
1.4.3.x.8	Low liquid line temperature	-50,1 [off] (-58,2)	200,0 (392,0)	-50,1 [off] (-58,2)	°C (F)
1.4.3.x.9	High liquid line temperature	-50,0 [off] (-58,0)	200,1 (392,2)	200,1 [off] (392,2)	°C (F)
1.4.3.x.10	Critical high liquid line temperature	-50,0 (-58,0)	200,1 [off] (392,2)	200,1 [off] (392,2)	°C (F)
1.4.3.x.11	Low subcooling	-0,1 [off] (-0,2)	50,0 (90,0)	-0,1 [off] (-0,2)	°C (F)
1.4.3.x.12	High subcooling	0,0	50,1 [off] (90,2)	50,1 [off] (90,2)	°C (F)
1.4.3.x.13	Hysteresis of temperature alarms	0,3 (0,5)	200,0 (360,0)	5,0 (9,0)	°C (F)

20.PARAMETER TABLE

1.4.3.x.1 Low pressure:

Enables the alarm when the pressure is lower than the configured value.

1.4.3.x.2 High pressure:

Enables the alarm when the pressure is higher than the configured value.

1.4.3.x.3 Critical high pressure:

Enables the alarm when the pressure is higher than the configured value. Generally higher than the value set in the high-pressure alarm (1.4.3.x.2).

1.4.3.x.4 Hysteresis of pressure alarms:

It is the pressure difference to get out of the alarm situation.

1.4.3.x.5 Low saturation temperature:

Enables the alarm when the temperature is lower than the configured value.

1.4.3.x.6 High saturation temperature:

Enables the alarm when the temperature is higher than the configured value.

1.4.3.x.7 Critical high saturation temperature:

Enables the alarm when the temperature is higher than the configured value. It is usually greater than the value configured in the high saturation temperature alarm (1.4.3.x.6).

1.4.3.x.8 Low liquid line temperature:

Enables the alarm when the temperature is lower than the configured value.

1.4.3.x.9 High liquid line temperature:

Enables the alarm when the temperature is higher than the configured value.

1.4.3.x.10 Critical high liquid line temperature:

Enables the alarm when the temperature is higher than the configured value. It is usually greater than the value configured in the high saturation temperature alarm (1.4.3.x.6).

1.4.3.x.11 Low subcooling:

Enables the alarm when the subcooling is lower than the configured value.

1.4.3.x.12 High subcooling:

Enables the alarm when the subcooling is higher than the configured value.

1.4.3.x.13 Hysteresis of temperature alarms:

It is the temperature variation necessary to get out of the alarm situation.

1.4.4 Reset:

Automatic reset settings for each suction and discharge line.

Function	Description	Minimum	Maximum	Standard	Unit
1.4.4.1	Number of attempts	0 [off]	11 [ever]	0	-
1.4.4.2	Time for retry	1	60	15	min
1.4.4.3	Reset period	1	24	1	h

1.4.4.1 Number of attempts:

Number of automatic reset attempts made within the Reset period (1.4.4.3).

1.4.4.2 Time for retry:

Time interval between two subsequent attempts of automatic reset.

1.4.4.3 Reset period:

This feature allows you to adjust the time for the number of automatic reset attempts (1.4.4.1). If all automatic resets have already been carried out within the time set in this feature and another fault occurs, the **RCK-862_{plus}** controller only resumes operation with a manual reset.

20.PARAMETER TABLE

1.4.5.x Alarm output:

The **RCK-862^{plus}** has up to six configurable alarm outputs. For each output, a specific alarm on the control lines can be linked and the output can be configured to cycle on and off or only on in the event of an alarm.

The letter x represents alarm outputs 1 to 6.

Function	Description	Minimum	Maximum	Standard	Unit
1.4.5.x.1	Suction / discharge pressure switch	0	9	0	-
1.4.5.x.2	Output function	0	31	0	-
1.4.5.x.3	Time on	0	999	0	sec
1.4.5.x.4	Time off	0	999	0	sec
1.4.5.x.5	Digital output	0	-	0	-
1.4.5.x.6	Contact type NO - NC	0	1/NC	0 [no]	-

1.4.5.x.1 Suction / discharge pressure switch:

Associates the alarm output to one of the lines:

0 = Off	3 = Suction 3	6 = Discharge 3	9 = Group 3
1 = Suction 1	4 = Discharge 1	7 = Group 1	
2 = Suction 2	5 = Discharge 2	8 = Group 2	

1.4.5.x.2 Output function:

The alarm output is linked with one of the following alarm events:

0 = Off	13 = Any temperature alarm	28 = Wet bulb temperature sensor fault
1 = Any alarm	14 = Digital input	29 = Compressor temperature sensor fault
2 = Low pressure	15 = Awaiting manual reset	30 = Fault in any sensor
3 = High pressure	16 = Critical overheating	31 = Stop by alarm
4 = Critical high pressure	17 = Low overheating	
5 = Any pressure alarm	18 = High overheating	
6 = Low pressure	19 = Any overheating alarm	
7 = High pressure	20 = Low subcooling	
8 = High critical temperature	21 = High subcooling	
9 = Fluid inlet temperature secondary low	22 = Any subcooling alarm	
10 = Fluid inlet temperature high secondary	23 = Pressure sensor fault	
11 = Outlet fluid temperature secondary low	24 = Temperature sensor fault	
12 = Outlet fluid temperature high secondary	25 = Temperature sensor failure secondary fluid inlet	
	26 = Temperature sensor failure secondary fluid outlet	
	27 = Dry bulb temperature sensor fault	

1.4.5.x.3 Time on:

Time that the output remains actuated in an alarm event.

1.4.5.x.4 Time off:

Time the output remains shutdown in an alarm event. When this time is set to OFF, the output will be activated if there is an alarm condition.

1.4.5.x.5 Digital output:

Digital output address for alarm.

0 = Not configured	4 = Base - O4
1 = Base - O1	5 = Base - O5
2 = Base - O2	6 = Base - O6
3 = Base - O3	

Note: If a sensor already in use is selected, it will be replaced.

1.4.5.x.6 Contact type:

Output polarity.

0 - NO: When the output is actuated, the contact is closed;

1 - NC: When the output is actuated, the contact is open.

20.PARAMETER TABLE

1.5 Actuation in case of sensor fault:

It allows configuring the status of each compressor or fan (on, off or cycling) in a sensor fault condition that measures the suction pressure or the discharge pressure / temperature. This logic serves to keep the system in emergency operation in the event of a sensor fault.

If a backup sensor is configured, this mode will only start if the main and backup sensors are faulty.

The letter x represents suctions (x between 1 and 3) and discharges (x between 4 and 6).

Function	Description	Minimum	Maximum	Standard	Unit
1.5.x.1	Compressor 1 capacity	0	100	50	%
1.5.x.2	Compressor 1	0 [off]	2/Cycling	0 [off]	%
1.5.x.3	Compressor 2	0 [off]	2/Cycling	0 [off]	-
1.5.x.4	Compressor 3	0 [off]	2/Cycling	0 [off]	-
1.5.x.5	Compressor 4	0 [off]	2/Cycling	0 [off]	-
1.5.x.6	Compressor 5	0 [off]	2/Cycling	0 [off]	-
1.5.x.7	Compressor 6	0 [off]	2/Cycling	0 [off]	-
1.5.x.8	Time on for cycle timer	1	60	5	min
1.5.x.9	Time off for cycle timer	1	60	5	min

1.5.x.1 Compressor 01 capacity:

Value of variable capacity for the compressor during operation with sensor failure..

1.5.x.2 to 1.5.x.7 Compressor / ventilador 01 a 06:

Define compressor status in case of sensor failure:

Off: Compressor or fan completely off;

On: Compressor or fan on;

Cyclic: Compressor cycling, according to times 1.5.x.8 and 1.5.x.9;

Example: Output 01 = off / Output 02 = on / Output 03 = off / Output 04 = cycling / Output 05 = cycling / Output 06 = off.

In this case, Compressor 2 remains continuously on, Compressors 1, 3, and 6 remain off, and Compressors 4 and 5 remain cycling. This condition will be maintained until the issue is corrected (sensor connection or replacement).

1.5.x.8 Time on for cycle timer:

Time that the compressor or fan remains on.

1.5.x.9 Time off for cycle timer:

Time that the compressor or fan remains off.

1.6 Auxiliary inputs:

It allows configuring up to 8 auxiliary inputs with specific functions.

The letter "x" represents digital inputs 1 to 30.

1.6.1 Auxiliary inputs:

Function	Description	Minimum	Maximum	Standard	Unit
1.6.x.1	Use link	0	23	0	-
1.6.x.2	Input function	0	45	0	-
1.6.x.3	Digital input address	0	-	0	-
1.6.x.4	Contact type NO-NC	0 [no]	1/NC	0 [no]	-

1.6.x.1 Use Link:

Links input x with a pressure switch, group, or auxiliary function according to:

0 = Off	5 = Discharge 2	10 = Group 2 Suction	15 = Pump Control 2	20 = Individual Thermostat 4
1 = Suction 1	6 = Discharge 3	11 = Group 3	16 = Pump Control 3	21 = Individual Thermostat 5
2 = Suction 2	7 = Group 1	12 = Group 3 Suction	17 = Individual Thermostat 1	22 = Individual Thermostat 6
3 = Suction 3	8 = Group 1 Suction	13 = All Pressure Switches	18 = Individual Thermostat 2	23 = All Outputs
4 = Discharge 1	9 = Group 2	14 = Pump Control 1	19 = Individual Thermostat 3	

20. PARAMETER TABLE

1.6.x.2 Input function:

Input x can have different functions associated with its activation and deactivation as follows:

- **None:** Function not configured, no effect.

- **Safety Input X:**

For Suction and Discharge: Immediately shuts off the compressor or fan x (1 to 6) from the associated suction or discharge line and logs an alarm event.

- **Economic Setpoint:** Changes the setpoint to economy mode.

- **Control Enable:** Enables or disables control of the suctions from auxiliary thermostats.

- **Shut Down All Outputs:** Turns off all compressors or fans associated with the pressure switch.

- **Low Pressure (LP):** In suction, during normal operation, has the same effect as a Low Pressure alarm and assumes compressor control in the event of a sensor failure. In discharge, it has the same effect as a Low Pressure alarm.

- **High Pressure (HP):** In suction, has the same effect as a High Pressure alarm. In discharge, it has the same effect as a critical High Pressure alarm.

- **Pump Down Activation:** Activates the pump-down shutdown function.

- **Adiabatic Condensation Enable:** Enables the adiabatic condensation control.

- **Dynamic Condensation Enable:** Enables the dynamic condensation control.

- **External Alarm 1 to 10:** Visual alarm.

- **External Fault 1 to 5:** Alarm that shuts down all compressors or fans in the configured suction or discharge line.

- **External Fault 6 to 10:** Alarm that shuts down all compressors or fans in the configured suction or discharge line, respecting the time between deactivations.

- **Pump X Flow:** Puts the respective pump (1 to 3) in alarm state, shuts it down, and activates another pump configured as Backup or Rotation.

- **Pump Flow:** Puts the operating pump in alarm state, shuts it down, and activates another pump configured as Backup or Rotation.

- **Compressor X Oil Alarm:** Puts the respective compressor (1 to 6) in alarm state and shuts it down.

- **External Thermostat:** Signal from an external thermostat that acts as the master of one or more suction lines.

0 = None

1 = Safety Input 1 (Available for 1.6.x.1 = 1 to 6)

2 = Safety Input 2 (Available for 1.6.x.1 = 1 to 6)

3 = Safety Input 3 (Available for 1.6.x.1 = 1 to 6)

4 = Safety Input 4 (Available for 1.6.x.1 = 1 to 6)

5 = Safety Input 5 (Available for 1.6.x.1 = 1 to 6)

6 = Safety Input 6 (Available for 1.6.x.1 = 1 to 6)

7 = Activate Economy Setpoint (Available for 1.6.x.1 = 1 to 13)

8 = Enable/Disable Control (Available for 1.6.x.1 = 1 to 6 and 17 to 22)

9 = Turn Off All Outputs (Available for any value of 1.6.x.1)

10 = Low Pressure (LP) (Available for 1.6.x.1 = 1 to 6)

11 = High Pressure (HP) (Available for 1.6.x.1 = 1 to 6)

12 = Activate Pump Down (Available for 1.6.x.1 = 1 to 3, 7 to 13)

13 = Activate Adiabatic Condensation (Available for 1.6.x.1 = 4 to 6, 7, 9, 11, 13)

14 = Activate Dynamic Condensation (Available for 1.6.x.1 = 4 to 6, 7, 9, 11, 13)

15 = External Alarm 1 (Available for 1.6.x.1 = 1 to 13)

16 = External Alarm 2 (Available for 1.6.x.1 = 1 to 13)

17 = External Alarm 3 (Available for 1.6.x.1 = 1 to 13)

18 = External Alarm 4 (Available for 1.6.x.1 = 1 to 13)

19 = External Alarm 5 (Available for 1.6.x.1 = 1 to 13)

20 = External Alarm 6 (Available for 1.6.x.1 = 1 to 13)

21 = External Alarm 7 (Available for 1.6.x.1 = 1 to 13)

22 = External Alarm 8 (Available for 1.6.x.1 = 1 to 13)

23 = External Alarm 9 (Available for 1.6.x.1 = 1 to 13)

24 = External Alarm 10 (Available for 1.6.x.1 = 1 to 13)

25 = External Fault 1 (Available for 1.6.x.1 = 1 to 13)

26 = External Fault 2 (Available for 1.6.x.1 = 1 to 13)

27 = External Fault 3 (Available for 1.6.x.1 = 1 to 13)

28 = External Fault 4 (Available for 1.6.x.1 = 1 to 13)

29 = External Fault 5 (Available for 1.6.x.1 = 1 to 13)

30 = External Fault 6 (Available for 1.6.x.1 = 1 to 13)

31 = External Fault 7 (Available for 1.6.x.1 = 1 to 13)

32 = External Fault 8 (Available for 1.6.x.1 = 1 to 13)

33 = External Fault 9 (Available for 1.6.x.1 = 1 to 13)

34 = External Fault 10 (Available for 1.6.x.1 = 1 to 13)

35 = Pump 1 Flow (Available for 1.6.x.1 = 14, 15, and 16)

36 = Pump 2 Flow (Available for 1.6.x.1 = 14, 15, and 16)

37 = Pump 3 Flow (Available for 1.6.x.1 = 14, 15, and 16)

38 = Pump Flow (Available for 1.6.x.1 = 14, 15, and 16)

39 = Compressor 1 Oil Alarm (Available for 1.6.x.1 = 1, 2, and 3)

40 = Compressor 2 Oil Alarm (Available for 1.6.x.1 = 1, 2, and 3)

41 = Compressor 3 Oil Alarm (Available for 1.6.x.1 = 1, 2, and 3)

42 = Compressor 4 Oil Alarm (Available for 1.6.x.1 = 1, 2, and 3)

43 = Compressor 5 Oil Alarm (Available for 1.6.x.1 = 1, 2, and 3)

44 = Compressor 6 Oil Alarm (Available for 1.6.x.1 = 1, 2, and 3)

45 = External Thermostat (Available for 1.6.x.1 = 1 to 12)

1.6.x.3 Digital Input Address:

Links the physical digital input address to input x.

0 = Not configured

1 = Base - HI1

2 = Base - HI2

3 = Base - HI3

4 = Base - I1

5 = Base - I2

6 = Base - I3

7 = Base - I4

8 = Base - I5



Note: The inputs present in the expansion modules will be listed in menu 4 after their configuration.

20.PARAMETER TABLE

1.6.x.4 Contact type NO-NC:

Actuation status at the input. NO is actuated via a normally open contact and NC is actuated via a normally closed contact.

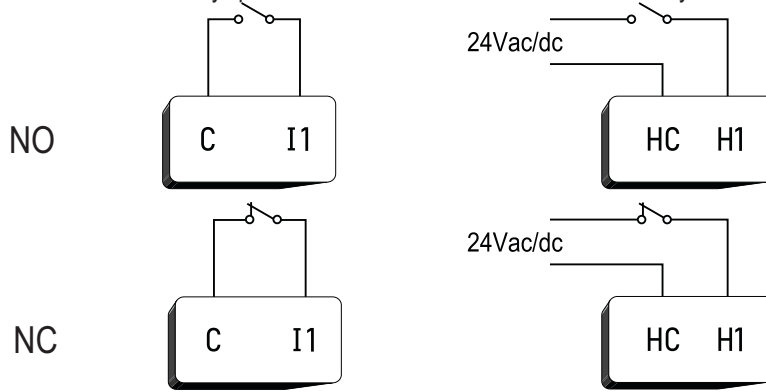

1.7 Auxiliary functions:

1.7.1 Pump Down:

Function	Description	Minimum	Maximum	Standard	Unit
1.7.1.x.1	Group 1: Shutdown pressure	-14,7 (-1,0)	3191,0 (220,0)	5,0 (0,3)	Psi (Bar)
1.7.1.x.2	Group 1: Maximum shutdown time	1	9999	30	sec
1.7.1.x.3	Group 1: Enables Pump Down	0 [no]	1 [yes]	0 [no]	-
1.7.1.x.4	Group 1: Digital output	0	-	0	-
1.7.1.x.5	Group 1: Contact type NO-NC	0 [NO]	1/ NC	0 [no]	-
1.7.1.x.6	Group 2: Shutdown pressure	-14,7 (-1,0)	3191,0 (220,0)	5,0 (0,3)	Psi (Bar)
1.7.1.x.7	Group 2: Maximum shutdown time	1	9999	30	sec
1.7.1.x.8	Group 2: Enables Pump Down	0 [no]	1 [yes]	0 [no]	-
1.7.1.x.9	Group 2: Digital output	0	-	0	-
1.7.1.x.10	Group 2: Contact type NO-NC	0 [NO]	1/ NC	0 [no]	-
1.7.1.x.11	Group 3: Shutdown pressure	-14,7 (-1,0)	3191,0 (220,0)	5,0 (0,3)	Psi (Bar)
1.7.1.x.12	Group 3: Maximum shutdown time	1	9999	30	sec
1.7.1.x.13	Group 3: Enables Pump Down	0 [no]	1 [yes]	0 [no]	-
1.7.1.x.14	Group 3: Digital output	0	-	0	-
1.7.1.x.15	Group 3: Contact type NO-NC	0 [NO]	1/ NC	0 [no]	-
1.7.1.x.16	Suction 1: Enables Pump Down	0 [no]	1 [yes]	0 [no]	-
1.7.1.x.17	Suction 1: Digital output	0	-	0	-
1.7.1.x.18	Suction 1: Contact type NO-NC	0 [NO]	1/ NC	0 [no]	-
1.7.1.x.19	Suction 2: Enables Pump Down	0 [no]	1 [yes]	0 [no]	-
1.7.1.x.20	Suction 2: Digital output	0	-	0	-
1.7.1.x.21	Suction 2: Contact type NO-NC	0 [NO]	1/ NC	0 [no]	-
1.7.1.x.22	Suction 3: Enables Pump Down	0 [no]	1 [yes]	0 [no]	-
1.7.1.x.23	Suction 3: Digital output	0	-	0	-
1.7.1.x.24	Suction 3: Contact type NO-NC	0 [NO]	1/ NC	0 [no]	-

1.7.1.x.1, 6 and 11 Group x: Shutdown pressure:

Pressure value indicating that the fluid has been completely withdrawn and the compressors are turned off.

1.7.1.x.2, 7 and 12 Group x: Maximum shutdown time:

Maximum time allowed for fluid collection. After this time has elapsed, the compressors are turned off.

1.7.1.x.3, 8 and 13 Group x: Enables Pump Down:

Enables the Pump Down shutdown function.

1.7.1.x.4, 9 and 14 Group x: Digital output:

Address digital output.

20.PARAMETER TABLE

1.7.1.x.5, 10 and 15 Group x: Contact type NO-NC:

State of actuation on entry. NO is actuated via a normally open contact and NC is actuated via a normally closed contact.

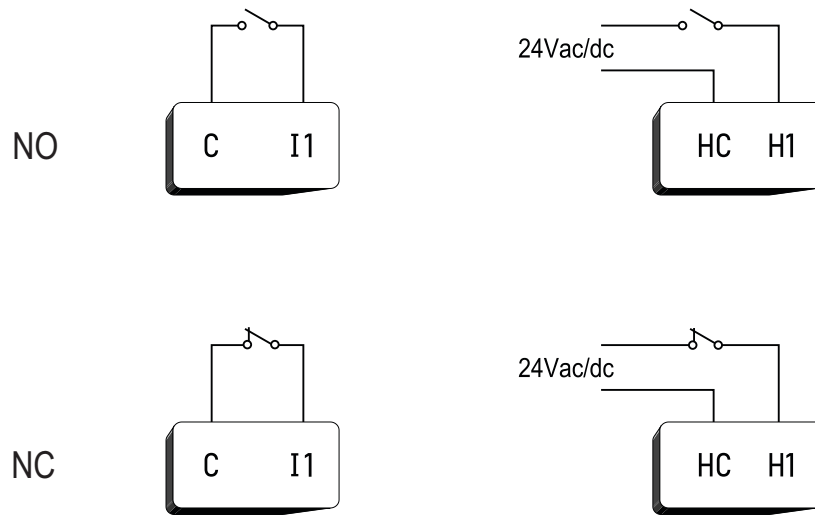

1.7.1.x.16, 19 and 22 Suction x: Enables Pump Down:

Enables shutdown with fluid collection in suction 1. In case of shutdown condition (setpoint or defrost) the last compressor remains in operation until it reaches the shutdown pressure or the maximum time of the group associated with this suction line.

1.7.1.x.17, 20 and 23 Suction x: Digital output:

Digital output address. The Pump Down digital output associated with a suction line can be used to inform the expansion valve controller that a defrost will be performed and that the valve can be closed or to actuate a fluid blocking solenoid.

1.7.1.x.18, 21 and 24 Suction x: Contact type NO-NC:

State of actuation on entry. NO is actuated via a normally open contact and NC is actuated via a normally closed contact.

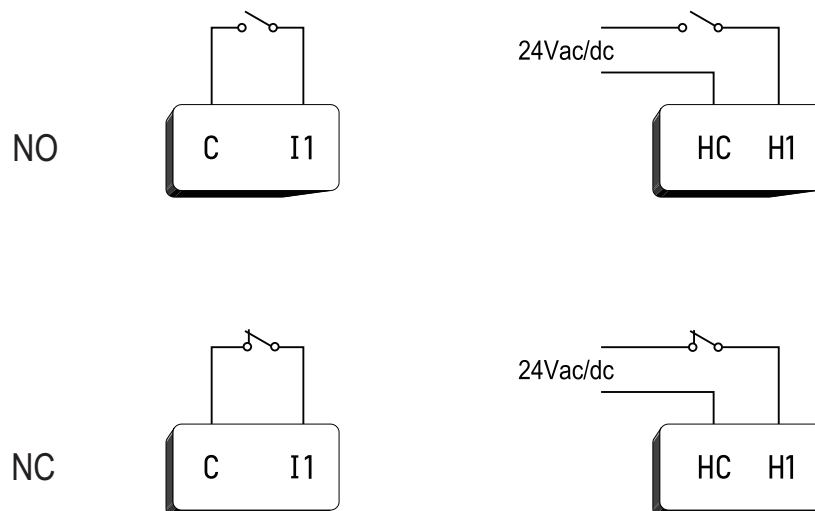

20.PARAMETER TABLE

1.7.2.x Compressor protection thermostat:

The letter x represents compressors 1 to 6 for each suction line.

Suction 1: x between 1 and 6.

Suction 2: x between 7 and 12.

Suction 3: x between 13 and 18.

Function	Description	Minimum	Maximum	Standard	Unit
1.7.2.x.1	Output control temperature	0 (32,0)	200,1 [off] (392,2)	200,1 [off] (392,2)	°C (F)
1.7.2.x.2	Compressor shutdown temperature	0 (32,0)	200,1 [off] (392,2)	200,1 [off] (392,2)	°C (F)
1.7.2.x.3	Hysteresis	0,1 (0,2)	200,0 (360,0)	5,0 (9)	°C (F)
1.7.2.x.4	Temperature sensor	0	-	0	-
1.7.2.x.5	Digital output	0	-	0	-

1.7.2.x.1 Output control temperature:

Control temperature value for actuating the cooling output.

1.7.2.x.2 Compressor shutdown temperature:

Temperature value for compressor shutdown and alarm indication.

1.7.2.x.3 Hysteresis:

It is the temperature range for controlling the fans linked with the digital outputs. This pressure value is related to the setpoint that defines the actuation points for each fan (actuation interval = setpoint + hysteresis).

1.7.2.x.4 Temperature sensor:

Address of the temperature sensor that measures the temperature of the compressor

0 = Not configured	4 = Base - S4
1 = Base - S1	5 = Base - S5
2 = Base - S2	6 = Base - S6
3 = Base - S3	



Note: The sensors present in the expansion modules will be listed in menu 4 after their configuration.

1.7.2.x.5 Digital output:

Digital output address controlled by the protection thermostat.

0 = Not configured	4 = Base - O4
1 = Base - O1	5 = Base - O5
2 = Base - O2	6 = Base - O6
3 = Base - O3	



Note: The outputs present in the expansion modules will be listed in menu 4 after their configuration.

1.7.3.x Adiabatic Condensation:

The letter x represents discharges 1 to 3.

Function	Description	Minimum	Maximum	Standard	Unit
1.7.3.x.1	Control mode	0	3	0	-
1.7.3.x.2	Temperature for actuation	-50,1 (-58,2)	200,1 [off] (392,2)	-50,1 (-52,2)	°C (F)
1.7.3.x.3	Temperature for shutdown	-50,1 (-58,2)	200,1 (392,2)	-50,1 (-52,2)	°C (F)
1.7.3.x.4	Activation differential	0 (0)	25,1 (45,2)	0 (0)	°C (F)
1.7.3.x.5	Shutdown differential	0 (0)	25,1 (45,2)	25,1 (45,2)	°C (F)
1.7.3.x.6	Minimum operating temperature (TBS)	-50,0 (-58,0)	200,0 (392,0)	18,0 (64,4)	°C (F)
1.7.3.x.7	Differential validation time	1	999	10	min
1.7.3.x.8	Time for next attempt	1	999	60	min
1.7.3.x.9	Dry bulb temperature sensor (TBS)	0	-	0	-
1.7.3.x.10	Wet bulb temperature sensor (TBU)	0	-	0	-
1.7.3.x.11	Digital output	0	-	0	-
1.7.3.x.12	Time on	1	999	5	min
1.7.3.x.13	Time off	1	999	5	min
1.7.3.x.14	Start time	00:00	24:00 [off]	24:00 [off]	hh:mm
1.7.3.x.15	End time	00:00	24:00 [off]	24:00 [off]	hh:mm

1.7.3.x.1 Control mode:

Configures the operation mode according to:

0 = Off	2 = Cycle timer
1 = By temperature	3 = Temperature with cycle timer

20.PARAMETER TABLE

1.7.3.x.2 Temperature for actuation:

Temperature of the dry bulb sensor to actuate the output.

1.7.3.x.3 Temperature for shutdown:

Temperature of the external temperature sensor (TBS) for shutting down the output.

1.7.3.x.4 Activation differential:

Value of the difference between dry and wet bulb temperatures for actuating the output.

1.7.3.x.5 Shutdown differential:

Value of the difference between dry and wet bulb temperatures for shutting down the output.

1.7.3.x.6 Minimum operating temperature (TBS):

Minimum ambient temperature for adiabatic condensation operation for differential control.

1.7.3.x.7 Differential validation time:

Maximum time to reach the shutdown differential (1.7.3.x.5).

1.7.3.x.8 Time for next attempt:

Time that the control waits before actuating the output for a new attempt to reach the shutdown differential

1.7.3.x.9 Dry bulb temperature sensor (TBS):

Defines the dry bulb temperature sensor.

1.7.3.x.10 Wet bulb temperature sensor (TBU):

Defines the wet bulb temperature sensor.

1.7.3.x.11 Digital output:

Digital output address

Sensors addresses:

0 = Not configured

1 = Base - O1

2 = Base - O2

3 = Base - O3

4 = Base - O4

5 = Base - O5

6 = Base - O6

Sensor options:

0 = Not configured

1 = Base - S1

2 = Base - S2

3 = Base - S3

4 = Base - S4

5 = Base - S5

6 = Base - S6



Note: The sensors present in the expansion modules will be listed in menu 4 after their configuration.

1.7.3.x.12 Time on:

Time length the output remains on in Cycle Timer Mode and Temperature with cycle timer.

1.7.3.x.13 Time off:

Time length the output remains off in Cycle Timer Mode and Temperature with cycle timer.

1.7.3.x.14 Start time:

Logic operating start time.



Note: If parameters 1.7.3.x.14 and 1.7.3.x.15 are set to OFF, the adiabatic condensation will remain active.

1.7.3.x.15 End time:

Logic operating end time.

1.7.4.1 Dynamic condensation:

The letter x represents discharges 1 to 3.

Function	Description	Minimum	Maximum	Standard	Unit
1.7.4.x.1	Fluctuation start temperature	-50,1 [off] (-58,2)	200,0 (392,2)	-50,1 [off] (-58,2)	°C (F)
1.7.4.x.2	Minimum setpoint value	-14,7 (-1,0)	3191,0 (220,0)	250,0 (17,2)	Psi (Bar)
1.7.4.x.3	Low subcooling for logic disable	0 (0)	200,0 (360,0)	1,0 (1,8)	°C (F)
1.7.4.x.4	Control temperature sensor	0	-	0	-
1.7.4.x.5	Start time	00:00 [off]	24:00 [off]	24:00 [off]	hh:mm
1.7.4.x.6	End time	00:00 [off]	24:00 [off]	24:00 [off]	hh:mm

20.PARAMETER TABLE

1.7.4.x.1 Fluctuation start temperature:

Temperature value for starting control of the discharge setpoint. Dynamic condensation operates below this value.

1.7.4.x.2 Minimum safety setpoint:

Minimum value of the pressure setpoint for the discharge.

1.7.4.x.3 Low subcooling for logic disable:

Minimum subcooling value. At this point, the reduction of the setpoint stops.

1.7.4.x.4 Control temperature sensor:

Defines the sensor used for dynamic condensation control. Typically, the same sensor configured for external discharge temperature is used, or one of the sensors configured for adiabatic condensation (TBS or TBU).

1.7.4.x.5 Start time:

Logic operating start time.

1.7.4.x.6 End time:

Logic operating end time.



Note: If parameters 1.7.4.x.5 and 1.7.4.x.6 are set to OFF, adiabatic condensation will remain active.



Attention: If a dry bulb temperature sensor has been configured for adiabatic condensation, it is not necessary to configure this parameter.

1.7.5.1 Individual pressure switches:

The letter x represents individual pressure switches 1 to 3.

Function	Description	Minimum	Maximum	Standard	Unit
1.7.5.x.1	Operation Mode	0	2	0	-
1.7.5.x.2	Pressure setpoint 1	0	3191,0 (220,0)	10,0 (0,7)	Psi (Bar)
1.7.5.x.3	Pressure setpoint 2	0	3191,0 (220,0)	20,0 (1,4)	Psi (Bar)
1.7.5.x.4	Pressure setpoint 3	0	3191,0 (220,0)	30,0 (2,1)	Psi (Bar)
1.7.5.x.5	Pressure setpoint 4	0	3191,0 (220,0)	40,0 (2,8)	Psi (Bar)
1.7.5.x.6	Pressure setpoint 5	0	3191,0 (220,0)	50,0 (3,4)	Psi (Bar)
1.7.5.x.7	Pressure setpoint 6	0	3191,0 (220,0)	60,0 (4,1)	Psi (Bar)
1.7.5.x.8	Pressure hysteresis 1	0	1600,0 (110,3)	10,0 (0,7)	Psi (Bar)
1.7.5.x.9	Pressure hysteresis 2	0	1600,0 (110,3)	10,0 (0,7)	Psi (Bar)
1.7.5.x.10	Pressure hysteresis 3	0	1600,0 (110,3)	10,0 (0,7)	Psi (Bar)
1.7.5.x.11	Pressure hysteresis 4	0	1600,0 (110,3)	10,0 (0,7)	Psi (Bar)
1.7.5.x.12	Pressure hysteresis 5	0	1600,0 (110,3)	10,0 (0,7)	Psi (Bar)
1.7.5.x.13	Pressure hysteresis 6	0	1600,0 (110,3)	10,0 (0,7)	Psi (Bar)
1.7.5.x.14	Pressure sensor	0	-	0	-
1.7.5.x.15	Digital output address 1	0	-	0	-
1.7.5.x.16	Digital output address 2	0	-	0	-
1.7.5.x.17	Digital output address 3	0	-	0	-
1.7.5.x.18	Digital output address 4	0	-	0	-
1.7.5.x.19	Digital output address 5	0	-	0	-
1.7.5.x.20	Digital output address 6	0	-	0	-
1.7.5.x.21	Low pressure alarm	-14,8 [off] (-1,1)	3191,0 (220,0)	-14,8 [off] (-1,1)	Psi (Bar)
1.7.5.x.22	High pressure alarm	0	3191,1 [off] (220,1)	3191,1 [off] (220,1)	Psi (Bar)
1.7.5.x.23	Hysteresis of alarms	1 (0,1)	1600,0 (110,3)	1 (0,1)	Psi (Bar)
1.7.5.x.24	Minimum time between actuations	1 [off]	9999	5	sec
1.7.5.x.25	Minimum output on time	1 [off]	9999	5	sec

1.7.5.x.1 Operation mode:

Configures the Operation Mode.

0 - Off

1 - Compression

2 - Descompression

1.7.5.x.2 to 1.7.5.x.7 Pressure setpoint 01-06:

Output pressure setpoint 01-06.

1.7.5.x.8 to 1.7.5.x.13 Pressure hysteresis 01-06:

Hysteresis of output 01-06.

20.PARAMETER TABLE

1.7.5.x.14 Pressure sensor:

Specifies the pressure sensor.

Sensor options:

0 = Not configured 4 = Base - S4
 1 = Base - S1 5 = Base - S5
 2 = Base - S2 6 = Base - S6
 3 = Base - S3



Note: The sensors present in the expansion modules will be listed in menu 4 after their configuration.

1.7.5.x.15 to 1.7.5.x.20 Digital output address 01-06:

Digital output address 01-06 linked to the individual pressure switch.

1.7.5.x.21 Low pressure alarm:

Enables the alarm indication when the pressure is lower than the configured value.

1.7.5.x.22 High pressure alarm:

Enables the alarm indication when the pressure is higher than the configured value.

1.7.5.x.23 Hysteresis of alarms:

Hysteresis of pressure alarms.

1.7.5.x.24 Minimum time between activations:

The function applies to the main control outputs of the individual pressure switches and is the minimum time between two actuations of the main digital outputs. This time guarantees that simultaneous activation of the digital outputs will not occur, avoiding surges in the supply network and excessive fluctuations in the control variable.

1.7.5.x.25 Minimum output on time:

Minimum output time on/off.

1.7.6 Individual thermostat:

The letter x represents individual thermostats 1 to 6.

Function	Description	Minimum	Maximum	Standard	Unit
1.7.6.x.1	Operation mode	0	2	0	-
1.7.6.x.2	Temperature setpoint	-50,0 (-58,0)	200,0 (392,0)	20,0 (68,0)	°C (°F)
1.7.6.x.3	Temperature hysteresis	0,1 (0,2)	200,0 (360,0)	5,0 (9,0)	°C (°F)
1.7.6.x.4	Low temperature alarm	-50,1 (-58,2)	200,0 (392,0)	-50,1 (-58,2)	°C (°F)
1.7.6.x.5	High temperature alarm	-50,0 (-58,0)	200,1 (392,2)	200,1 (392,2)	°C (°F)
1.7.6.x.6	Hysteresis of alarms	0,1 (0,2)	200,0 (360,0)	5,0 (9,0)	°C (°F)
1.7.6.x.7	Control temperature sensor	0	*	0	-
1.7.6.x.8	Temperature sensor for defrost end	0	3	0	-
1.7.6.x.9	Control output	0	*	0	-
1.7.6.x.10	Defrost output	0	*	0	-
1.7.6.x.11	Fan output	0	*	0	-
1.7.6.x.12	Minimum compressor on time	1	9999		sec
1.7.6.x.13	Minimum compressor off time	1	9999		sec
1.7.6.x.14	Control Link	0	3	0	-
1.7.6.x.15	Interlock time	0	9999	0	sec
1.7.6.x.16	Fluid recovery time before defrost starts	0	9999	5	sec
1.7.6.x.17	Draining time	0	999	5	sec
1.7.6.x.18	Fan return temperature after draining	-50,1 [Off] (-58,2)	200,0 (392,0)	-50,1 [Off] (-58,2)	°C (°F)
1.7.6.x.19	Maximum time for fan return after draining	0	9999	5	sec
1.7.6.x.20	Startup defrost	0	1	0	-
1.7.6.x.21	Defrost end temperature	-50,0 (-58,0)	200,0 (392,0)	30,0 (86,0)	°C (°F)
1.7.6.x.22	Interval between defrosts	0	9999	240	-
1.7.6.x.23	Defrost length	0	9999	30	-
1.7.6.x.24	Defrost time 1	0	00:00	24:00	-
1.7.6.x.25	Defrost time 2	0	00:00	24:00	-
1.7.6.x.26	Defrost time 3	0	00:00	24:00	-
1.7.6.x.27	Defrost time 4	0	00:00	24:00	-
1.7.6.x.28	Defrost time 5	0	00:00	24:00	-
1.7.6.x.29	Defrost time 6	0	00:00	24:00	-

20.PARAMETER TABLE

1.7.6.x.1 Operation mode:

Configures the Operation Mode.

- 0 = Off
- 1 = Heating
- 2 = Cooling

1.7.6.x.2 Temperature setpoint:

Output temperature setpoint.

1.7.6.x.3 Temperature hysteresis:

Temperature control hysteresis linked to individual thermostat output.

1.7.6.x.4 Low pressure alarm:

Enables the alarm indication when the temperature is lower than the configured value.

1.7.6.x.5 High pressure alarm:

Enables the alarm indication when the temperature is higher than the configured value.

1.7.6.x.6 Hysteresis of alarms:

Hysteresis of temperature alarms.

1.7.6.x.7 Control temperature sensor:

Defines the temperature sensor used for controlling the control output.

1.7.6.x.8 Temperature sensor for defrost end:

Defines the temperature sensor for defrost termination.

1.7.6.x.9 Control output:

Address of the control output.

1.7.6.x.10 Defrost output:

Address of the defrost output.

1.7.6.x.11 Fan output:

Address of the fan output.

1.7.6.x.12 Minimum compressor on time:

Minimum operating time for the control output.

1.7.6.x.13 Minimum compressor off time:

Minimum off time for the control output.

1.7.6.x.14 Control Link:

Defines a suction line to be controlled by the thermostat, meaning the suction line is only enabled while the thermostat is in the refrigeration process.

- 0 = Not linked
- 1 = Suction 1
- 2 = Suction 2
- 3 = Suction 3

1.7.6.x.15 Interlock time:

Time between entering the refrigeration process and enabling the linked suction line. During this period, only the fan output is activated.

1.7.6.x.16 Fluid recovery time before defrost starts:

When starting defrost, the controller keeps only the fan running during this time, utilizing the residual energy from the refrigerant. In the case of defrost upon energization, this time will be disregarded.

1.7.6.x.17 Draining time:

Time required for dripping, allowing the last drops of water to drain from the evaporator. During this period, all outputs remain off.

1.7.6.x.18 Fan return temperature after draining:

After draining, the fan-delay cycle begins. The compressor is activated immediately since the evaporator temperature is high, but the fan only starts after the evaporator temperature drops to the set value. This process is necessary to remove residual heat from the evaporator caused by the defrost, preventing it from being released into the environment.

20.PARAMETER TABLE

1.7.6.x.19 Maximum time for fan return after draining:

For safety, if the evaporator temperature does not reach the value set in the previous function or the evaporator temperature sensor is disconnected, the fan will return after the time configured in this function has elapsed.

1.7.6.x.20 Startup defrost:

Determines that the thermostat enters the defrost process when the controller is energized or when the thermostat control is manually enabled or via digital input.

1.7.6.x.21 Defrost end temperature:

When the evaporator temperature is equal to or greater than the value set in this function, the defrost process will end. If the evaporator temperature is higher than the value set in this function, the defrost process will not start.

1.7.6.x.22 Interval between defrosts:

Time interval between the defrosts.

1.7.6.x.23 Defrost length:

Time interval during which the thermostat remains in defrost.

1.7.6.x.24 to 1.7.6.x.29 Defrost time:

It allows configuring a specific time to defrost.

1.7.7 Pump control:

Function	Description	Minimum	Maximum	Standard	Unit
1.7.7.x.1	Time for rotation outputs	0	9999	720	min
1.7.7.x.2	Time of transition between pumps	0	9999	5	sec
1.7.7.x.3	Time to start compressors after activating pumps	0	9999	5	sec
1.7.7.x.4	Digital output of pump 1	0	-	0	-
1.7.7.x.5	Digital output of pump 2	0	-	0	-
1.7.7.x.6	Digital output of pump 3	0	-	0	-
1.7.7.x.7	Operation mode of pump 2	0	1	0	-
1.7.7.x.8	Operation mode of pump 3	0	1	0	-
1.7.7.x.9	Control link	0	6	1	-
1.7.7.x.10	Shut off pumps after suction shutdown	0	1	0	-
1.7.7.x.11	Time to turn off pumps after suction shutdown	0	9999	120	sec

1.7.7.x.1 Time for rotation outputs:

Operation time of an output before entering the rotation cycle.

1.7.7.x.2 Time of transition between pumps:

Time during which both outputs remain on during rotation.

1.7.7.x.3 Time to start compressors after activating pumps:

Time between activating the pumps and starting the first compressor of the linked suction.

1.7.7.x.4 Digital output of pump 1:

Defines the digital output for pump 1.

1.7.7.x.5 Digital output of pump 2:

Defines the digital output for pump 2.

1.7.7.x.6 Digital output of pump 3:

Defines the digital output for pump 3.

1.7.7.x.7 Operation mode of pump 2:

Defines the operation mode of pump 2.

Rotation: Participates in the rotation cycle. If there is no reserve pump, it replaces a pump in alarm or under maintenance.

Reserve: Replaces a pump that goes into alarm or is placed under maintenance. Does not participate in the rotation cycle.

0 = Rotation

1 = Reserve

1.7.7.x.8 Operation mode of pump 3:

Defines the operation mode of pump 3.

Rotation: Participates in the rotation cycle. If there is no reserve pump, it replaces a pump in alarm or under maintenance.

Reserve: Replaces a pump that goes into alarm or is placed under maintenance. Does not participate in the rotation cycle.

20.PARAMETER TABLE

1.7.7.x.9 Control link:

Defines which suction lines remain linked to the pump control. The link between the pump control and a suction line establishes a relationship where the compressors can only operate if there is flow of secondary fluid, i.e., if at least one pump is operating.

0 = Not linked	
1 = Suction 1	4 = Group 1 Suctions
2 = Suction 2	5 = Group 2 Suctions
3 = Suction 3	6 = Group 3 Suctions

1.7.7.x.10 Shut off pumps after suction shutdown:

Defines whether the pumps should be disabled after the compressors stop in cases of suction shutdown via control menu or digital input. When compressor shutdown is due to normal shutdown, defrost, or alarm, the pumps remain operating. Pump control resumes before the compressors start when the suction control is reactivated.

1.7.7.x.11 Time to turn off pumps after suction shutdown:

Determines the time between compressor shutdown and pump disablement.

1.7.8 Control status output:

Function	Description	Minimum	Maximum	Standard	Unit
1.7.8.1	Output for control on indication	0	-	0	-

1.7.8.1 Output for control on indication:

Digital output indicating that the controller is operating.

1.7.9 Defrost for suction lines:

Function	Description	Minimum	Maximum	Standard	Unit
1.7.9.x.1	Condition for starting defrost	0	3	0	-
1.7.9.x.2	Interval between defrost	1	9999	240	min
1.7.9.x.3	Number of defrost per day (Monday to Friday)	1	12	4	-
1.7.9.x.4	Time to start defrost (Monday to Friday)	00:00	23:59	06:00	hh:mm
1.7.9.x.5	Number of defrost per day (Saturday)	1	12	4	-
1.7.9.x.6	Time to start defrost (Saturday)	00:00	23:59	06:00	hh:mm
1.7.9.x.7	Number of defrost per day (Sunday)	1	12	4	-
1.7.9.x.8	Time to start defrost (Sunday)	00:00	23:59	06:00	hh:mm
1.7.9.x.9	Defrost time	1	999	30	min

1.7.9.x.1 Condition for starting defrost:

Determines the condition for starting defrost.

0 = Off. Does not perform defrost
1 = Manual defrost only;
2 = Time;
3 = Schedule.

1.7.9.x.2 Interval between defrosts:

Determines how often the defrost will be performed, with the time counting from the end of the previous defrost. Using when 1.7.9.x.1 = 1.

1.7.9.x.3 Number of defrost per day (Monday to Friday):

The defrost are distributed at equal intervals according to the schedule of the number of defrost per day, always considering the preferred time. This function is for programming from Monday to Friday. Allowed values are: 1, 2, 3, 4, 6, 8 or 12.

1.7.9.x.4 Time to start defrost:

A preferred (reference) time must be set so that one of the day's defrost takes place. This function is for programming from Monday to Friday.

1.7.9.x.5 and 1.7.9.x.6 Saturday:

A preferred (reference) time must be set so that one of the day's defrost takes place. This function is for Saturday programming.

1.7.9.x.7 and 1.7.9.x.8 Sunday:

A preferred (reference) time must be set so that one of the day's defrost takes place. This function is for Sunday programming.

1.7.9.x.9 Defrost time:

Time the suction line remains in defrost.

20.PARAMETER TABLE

1.7.10 Antifreeze (6 sets):

Function	Description	Minimum	Maximum	Standard	Unit
1.7.10.x.1	Minimum antifreeze alarm temperature	-50,1 [Off] (-58,2)	200,0 (392,0)	-50,1 [Off] (-58,2)	°C (°F)
1.7.10.x.2	Control output activation temperature	-50,1 [Off] (-58,2)	200,0 (392,0)	-50,1 [Off] (-58,2)	°C (°F)
1.7.10.x.3	Compressor shutdown temperature	-50,1 [Off] (-58,2)	200,0 (392,0)	-50,1 [Off] (-58,2)	°C (°F)
1.7.10.x.4	Temperature hysteresis	0,1 (0,2)	200,0 (360,0)	5,0 (9,0)	°C (°F)
1.7.10.x.5	Low differential alarm	0,0 [Off]	200,0 (360,0)	0,0 [Off] (0,0)	°C (°F)
1.7.10.x.6	High differential alarm	0	200,1 [Off] (360,2)	200,1 [Off] (360,2)	°C (°F)
1.7.10.x.7	Differential type alarm hysteresis	0	200,0 (360,0)	1,0 (1,8)	°C (°F)
1.7.10.x.8	Control temperature sensor	0	-	0	-
1.7.10.x.9	Inlet temperature sensor	0	-	0	-
1.7.10.x.10	Outlet temperature sensor	0	-	0	-
1.7.10.x.11	Control output	0	-	0	-
1.7.10.x.12	Control Link	0	6	0	-

1.7.10.x.1 Minimum antifreeze alarm temperature:

Temperature value below which the low differential temperature alarm is allowed.

1.7.10.x.2 Control output activation temperature:

The control output is activated when the control sensor temperature is below the value configured in this function.

1.7.10.x.3 Compressor shutdown temperature:

When the control sensor temperature is below the value configured in this function, the compressors of the suction lines linked to this antifreeze logic are turned off, and an alarm event is generated.

1.7.10.x.4 Temperature hysteresis:

Temperature differential considered for deactivating the control output and restarting the compressors of the associated suction lines.

1.7.10.x.5 Low differential alarm:

Difference in temperature between the outlet and inlet of the secondary fluid to trigger a low differential temperature alarm.

1.7.10.x.6 High differential alarm:

Difference in temperature between the outlet and inlet of the secondary fluid to trigger a high differential temperature alarm.

1.7.10.x.7 Differential type alarm hysteresis:

Temperature differential for activating the low and high differential alarm outputs.

1.7.10.x.8 Control temperature sensor:

Defines the control temperature sensor.

1.7.10.x.9 Inlet temperature sensor:

Defines the inlet temperature sensor of the secondary fluid.

1.7.10.x.10 Outlet temperature sensor:

Defines the outlet temperature sensor of the secondary fluid.

1.7.10.x.11 Control output:

Defines the digital output for control of the logic.

1.7.10.x.12 Control link:

Defines which suction lines have a control link with the antifreeze logic. The compressor shutdown temperature function applies to the compressors of the linked suction line.

0 = Not linked	
1 = Suction 1	4 = Group 1 Suctions
2 = Suction 2	5 = Group 2 Suctions
3 = Suction 3	6 = Group 3 Suctions

20.PARAMETER TABLE

1.7.11 Economizer, 3 sets or 3 suctions:

Function	Description	Minimum	Maximum	Standard	Unit
1.7.11.x.1	Enables economizer 1 (compressor 1 of suction 1)	0	1	0	-
1.7.11.x.2	Activation delay	0	9999	300	sec
1.7.11.x.3	Minimum activation capacity	10	100	75	%
1.7.11.x.4	Minimum deactivation capacity	10	100	50	%
1.7.11.x.5	Minimum evaporation temperature	-50,0 (-58,0)	200,1 [Off] (392,2)	200,1 [Off] (392,2)	°C (°F)
1.7.11.x.6	Maximum condensation temperature	-50,0 (-58,0)	200,1 [Off] (392,2)	200,1 [Off] (392,2)	°C (°F)
1.7.11.x.7	Condensation temperature hysteresis	0,1 (0,2)	200,0 (360,0)	30,0 (54,0)	°C (°F)
1.7.11.x.8	Minimum discharge temperature	-50,1 [Off] (-58,2)	200,0 (392,0)	-50,1 [Off] (-58,2)	°C (°F)
1.7.11.x.9	Discharge temperature hysteresis	0,1 (0,2)	200,0 (360,0)	30,0 (54,0)	°C (°F)
1.7.11.x.10	Digital output	0	-	0	-
1.7.11.x.11	Contact activation type	0	1	0	-
1.7.11.x.12	Discharge temperature sensor	0	-	0	-
1.7.11.x.13	Line pressure sensor	0	-	0	-

1.7.11.x.1 Enables economizer 1 (compressor 1 of suction 1):

Enables economizer control for compressor 1 of suction line 1.

1.7.11.x.2 Activation delay:

Time to enable the economizer output after the compressor starts.

1.7.11.x.3 Minimum activation capacity:

Minimum operating capacity to allow economizer output activation.

Note: The manufacturer should be consulted regarding compressor operating conditions during economizer operation.

1.7.11.x.4 Minimum deactivation capacity:

Operating capacity value below which the economizer output is deactivated.

1.7.11.x.5 Minimum evaporation temperature:

Defines an evaporation temperature value of the refrigerant to be reached in order to allow economizer activation. If this function is set to 0 ¢ ¢, the economizer output activation does not consider the evaporation temperature.

1.7.11.x.6 Maximum condensation temperature:

Maximum condensation temperature value, obtained from the discharge line pressure sensor, to allow economizer activation. If this function is set to 0 ¢ ¢, the economizer output activation does not consider the condensation temperature.

1.7.11.x.7 Condensation temperature hysteresis:

Temperature differential for reactivation of the output after shutdown due to high condensation temperature.

1.7.11.x.8 Minimum discharge temperature:

Minimum discharge temperature value of the compressor to allow economizer activation, ensuring operation within limits. If this function is set to 0 ¢ ¢, the economizer output activation does not consider the compressor discharge temperature.

Note: When the discharge sensor is installed on the piping, it should be considered that the pipe temperature is generally 10K higher than the compressor discharge chamber temperature.

1.7.11.x.9 Discharge temperature hysteresis:

Temperature differential for reactivation of the output after shutdown due to low discharge temperature.

1.7.11.x.10 Digital output:

Defines the digital output for economizer system activation.

1.7.11.x.11 Contact activation type:

Defines the control output state when activated:

0 = NO
1 = NC

1.7.11.x.12 Discharge temperature sensor:

Defines the compressor discharge temperature sensor.

1.7.11.x.13 Line pressure sensor:

Defines a pressure sensor for monitoring the fluid pressure in the economizer circuit.

20.PARAMETER TABLE

1.8 Maintenance time:

Time setting for maintenance of compressors and fans.

1.8.x Suction / Discharge:

The letter x represents suction (x between 1 and 3) and discharges (x between 4 and 6).

Function	Description	Minimum	Maximum	Standard	Unit
1.8.x.1	Maintenance time for compressor / fan 01	0 [off]	9999	0 [off]	h
1.8.x.2	Maintenance time for compressor / fan 02	0 [off]	9999	0 [off]	h
1.8.x.3	Maintenance time for compressor / fan 03	0 [off]	9999	0 [off]	h
1.8.x.4	Maintenance time for compressor / fan 04	0 [off]	9999	0 [off]	h
1.8.x.5	Maintenance time for compressor / fan 05	0 [off]	9999	0 [off]	h
1.8.x.6	Maintenance time for compressor / fan 06	0 [off]	9999	0 [off]	h

1.8.x.1 Time for compressor / fan maintenance 1 to 6:

Time for the alarm of hours worked of the compressor or fan.

1.9 Sensors and outputs:

Settings related to sensors.

1.9.x Sensors:

The letter x represents the sensor inputs.

Function	Description	Minimum	Maximum	Standard	Unit
1.9.x.1	Pressure at 4mA	-14,7 (-1,0)	3191,0 (220,0)	0,0 (0,0)	Psi (Bar)
1.9.x.2	Pressure at 20mA	-14,7 (-1,0)	3191,0 (220,0)	500,0 (34,5)	Psi (Bar)
1.9.x.3	Pressure offset	-50,0 (-3,4)	50,0 (-3,4)	0,0 (0,0)	Psi (Bar)
1.9.x.4	Temperature offset	-50,0 (-3,4)	-50,0 (-3,4)	0,0 (0,0)	°C (°F)

1.9.x.1 Pressure at 4mA:

Sensor pressure value at 4mA (low full scale).

1.9.x.2 Pressure at 20mA:

Sensor pressure value at 20mA (high full scale).

1.9.x.3 Pressure offset:

It allows to offset deviations in the pressure reading.

1.9.x.4 Temperature offset:

It allows to offset deviations in the temperature reading.

20.PARAMETER TABLE

1.10 Analog outputs:

Configuration of limit values for the analog outputs.

1.10.x Outputs A1-A10:

The letter X represents the outputs.

Function	Description	Minimum	Maximum	Standard	Unit
1.10.x.1	A1 - Action range	0	3	0	-

1.10.x.1 Action range A1-A10:

Defines the action range of the output voltage. The minimum voltage value corresponds to 0%, and the maximum value corresponds to 100% of the capacity of the associated compressor or fan.

0=0-10V

1=0-5V

2=1-5V

3=1-10V

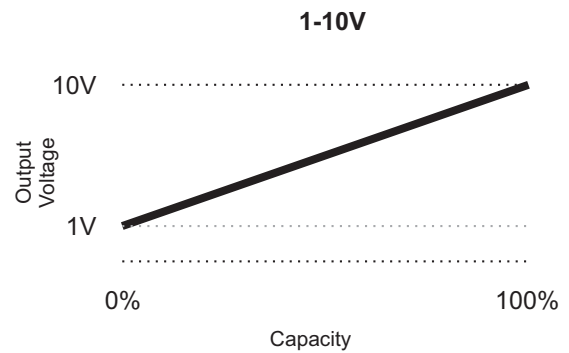
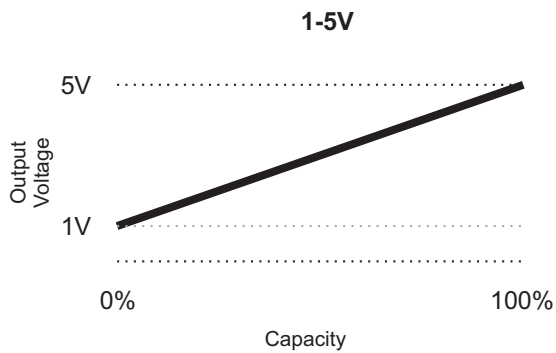
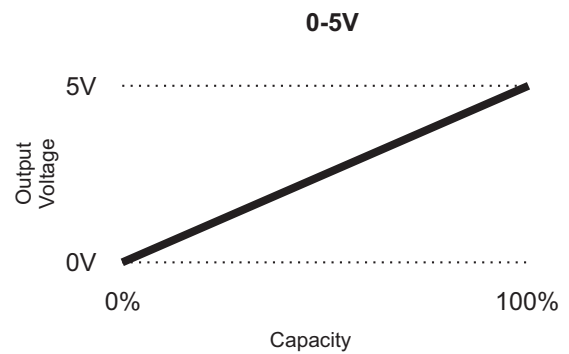
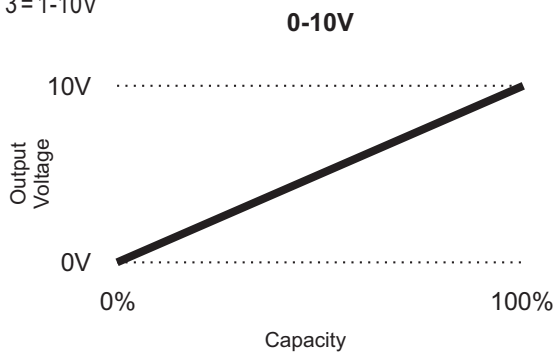

1.11 Refrigerant curves: - Point 1 to point 20:

It allows to adjust a customized saturated refrigerant curve. If you want to use a refrigerant that is not included in the list, you can enter the saturation, pressure, and temperature values. The pressure and temperature values must be entered in ascending order from 1 to 20, that is, values from point 2 must be greater than the values of point 1. A minimum of 10 points must be configured for control. (Point 1 to point 10).

The letter "x" represents points 1 to 20.

Function	Description	Minimum	Maximum	Standard	Unit
1.11.x.1	Point x - Pressure of the mapped curve	-14,8 [off] (-1,1)	3191,0 (220,0)	-14,8 [off] (-1,1)	Psi (Bar)
1.11.x.2	Point x - Temperature of the mapped curve	-50,1 (-58,2)	200,0 (392,0)	-50,1 (-58,2)	°C (°F)

1.11.x.1 Point x - Pressure of the mapped curve:

Point pressure value.

1.11.x.2 Point x - Temperature of the mapped curve:

Point temperature value.

21. IMPORTANT

According to NBR 5410 standard chapters:

- 1: Install surge protectors in the supply
- 2: Sensor and serial communication cables can be assembled, but not in the same conduit through which power supply and charge actuation pass
- 3: Install transient suppressors (RC filter) in parallel to the charges, to increase the life span of relays.

Wiring schematics for suppressors in contactors

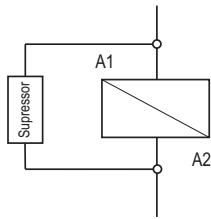

A1 and A2 are the contactor coil terminals

Wiring schematics for suppressors on charges with direct actuation

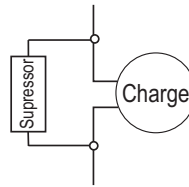

For light direct delivery maximum current Specified.

Full Gauge Controls makes suppressors available for sale

22. WARRANTY



ENVIRONMENTAL INFORMATION

Packing:

The materials used in the packaging of Full Gauge products are 100% recyclable. Try to dispose of it through specialized recycling agents.

Product:

The components used in Full Gauge controllers can be recycled and reused if disassembled by specialized companies.

Disposal:

Do not burn or dispose of controllers that reach the end of their life span in household trash. Observe the existing effective legislation in your region regarding the disposal of electronic waste. In case of any doubts, contact Full Gauge Controls.

WARRANTY TERM - FULL GAUGE CONTROLS

The products manufactured by Full Gauge Controls, from May 2005, have a warranty period of 10 (ten) years directly with the factory and 01 (one) year with accredited resellers/dealers, from the date of the consigned sale on the invoice. After this year with resellers, the warranty will continue to be effective if the instrument is sent directly to Full Gauge Controls. This period is valid for the Brazilian market. Other countries have a 2 (two) year warranty. The products are guaranteed in case of manufacturing failure that makes them improper or unsuitable for the applications for which they are intended. The warranty is limited to the maintenance of instruments manufactured by Full Gauge Controls, disregarding other types of expenses, such as indemnification due to damages caused to other equipment.

EXCEPTIONS TO WARRANTY

The Warranty does not cover transport and / or insurance costs for sending products with indications of defect or malfunction to Technical Assistance. The following events are also not covered: natural wear of parts, external damage caused by falls or improper packaging of products.

LOSS OF WARRANTY

The product will automatically lose its warranty if:

- The instructions for use and assembly in the technical description and the installation procedures present in Standard NBR5410 are not observed;
- It is subjected to conditions beyond the limits specified in its technical description;
- It is violated or repaired by a person who is not part of Full Gauge's technical team;
- The damage is caused by a fall, blow and / or impact, water infiltration, overload and / or atmospheric discharge.

WARRANTY USE

To be covered and benefit from the guarantee, the customer must send the product properly packed, together with the corresponding purchase invoice, to Full Gauge Controls. Shipping costs for products are at customer's costs. It is also necessary to send as much information as possible regarding the detected defect, thus making it possible to streamline the analysis, testing and service.

These processes and eventual product maintenance will only be carried out by Full Gauge Controls' Technical Assistance, at the Company's headquarters- Rua Júlio de Castilhos, 250, CEP 92120-030 - Canoas - Rio Grande do Sul - Brazil.

© Copyright 2025 • Full Gauge Controls® • All rights reserved