



# MT-543E Log Ver.04

FOUR-STAGE DIGITAL CONTROLLER WITH ALARM, CYCLICAL TIMER, SERIAL COMMUNICATION, AND HACCP FUNCTIONS



CE US E251415

MT543ELOGV04-04T-19616-2604

Have this manual to hand when using the FG Finder application.

HACCP function

Audible alarm

Cyclical timer

Functions lock

Datalogger

Serial programming

Sitrad Supervisory system

IP 65 FRONT Degree of protection

## WARNING

**BEFORE INSTALLING THE CONTROLLER WE RECOMMEND READING THE INSTRUCTION MANUAL THOROUGHLY IN ORDER TO AVOID POSSIBLE DAMAGES TO THE PRODUCT.**

**PRECAUTIONS WHEN INSTALLING THE PRODUCT:**  
Before performing any procedure in this instrument, disconnect it from the mains; make sure the instrument has proper ventilation, avoiding installation in panels containing devices that may force it to work outside the specified temperature limits; Install the product away from sources that can generate electromagnetic disturbances, such as: motors, contactors, relays, solenoid valves, etc.

**AUTHORIZED SERVICES:**  
The installation and maintenance of the product must only be performed by qualified personnel.

**ACCESSORIES:**  
Only use original accessories of Full Gauge Controls.  
If you have any questions, please contact our technical support.

**DUE TO CONSTANT EVOLUTION, FULL GAUGE CONTROLS RESERVES THE RIGHT TO CHANGE THE INFORMATION CONTAINED IN THIS MANUAL.**

## 1. DESCRIPTION

The MT-543e Log controller has four stages that can be applied to refrigeration or heating: the first stage, together with the third stage, works in systems that require minimum ventilation; the third one works as a cyclical timer; the fourth one works as an alarm. The second, third and fourth stages work also in the following modes: refrigeration, heating, refrigeration (Sp1), heating (SP1) and refrigeration in rotation. It also has a fifth latch that can be used as power failure alert and / or alarm.

The **MT-543E Log** accepts three types of sensors: NTC thermistor (-50 to 105 °C\*), PT100\*\* and PT1000\*\* (-200 to 300 °C). It has an intelligent functions lock system, a mode to switch off the control functions, an internal audible alarm (buzzer), and a configurable digital filter.

It allows the stages to be used in an independent way or in rotation mode (alternating the outputs). It features an internal memory (datalogger), where the temperature value is stored in user-defined time periods, the temperature variation and the state of the outputs. In addition, it has built-in rechargeable battery and clock to keep track of data even in case of power failure and serial port for communications with Sitrad.

It also allows monitoring of HACCP critical points (Hazard Analysis and Critical Control Point) by means of records in the controller's memory of high temperature alarm, power failure, and digital input.

Product in compliance with UL Inc. (United States and Canada)\*\*\*.

## 2. APPLICATIONS

- Blood banks
- Vaccines
- Multistage temperature systems
- Air conditioners
- Datacenters

## 3. TECHNICAL SPECIFICATIONS

Power supply	MT-543E Log: 90~240 Vac (50/60 Hz)*** MT-543EL Log: 12 or 24 Vac/dc +10%
Approximate consumption	0,6 VA
Control temperature	NTC: -50 to 200°C / -58 to 392°F* PT100: -200 to 300°C / -328 to 572°F** PT1000: -200 to 300°C / -328 to 572°F**
Operating temperature	-20 to 60°C / -4 to 140°F
Maximum output current / power	OUT1, OUT2, OUT3, OUT4: 120-240 Vac, 5A Resistive 240 Vac, 1/8 HP 120 Vac, 1/10 HP 120-240 Vac 5W Geral Use OUT5 (NC): 24Vdc/15W
Operating humidity	10 to 90% UR (no condensation)
Dimensions	76 x 34 x 77 mm - 2,99" x 1,33" x 3,03" (WxHxP)
Dimensions of the clip for fixing the instrument	71 ± 0,5 x 29 ± 0,5 mm - 2,79" ± 0,02" x 1,14" ± 0,02"

Note: Sensor cable length can be increased to up to 200 meters by the user by using a PP2 x 24 AWG cable.

\*It measures temperatures up to 200 °C using the SB59 (sold separately).

\*\*This sensor is sold separately.

\*\*\*The model with a power supply voltage of 90~240 Vac is UL certified.

## 4. 4. INDICATIONS AND KEYS

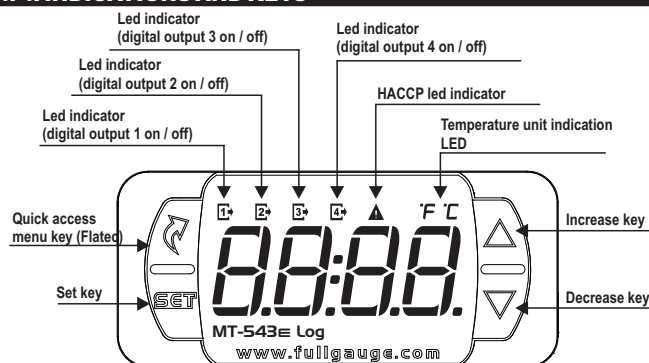

## 5. INSTALLATION - PANEL AND ELECTRIC CONNECTIONS

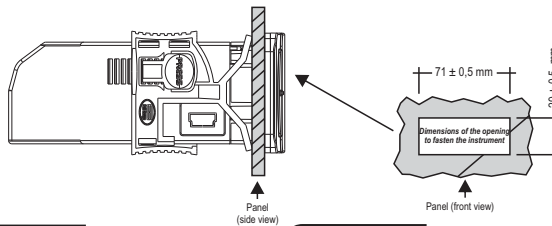

### WARNING

FOR INSTALLATIONS THAT REQUIRE WATER TIGHTNESS, TO INSTALL THE CONTROLLER THE OPENING MUST BE 70.5 x 29 mm MAXIMUM. THE SIDE LATCHES MUST BE FIXED SO THAT PRESSURE IS APPLIED TO THE SEALING GASKET TO PREVENT INFILTRATION BETWEEN THE OPENING AND THE CONTROLLER.

### IMPORTANT

IT IS ESSENTIAL TO USE PROPER TOOLS IN ORDER TO AVOID DAMAGES TO THE INSTRUMENT'S CONNECTION TERMINALS:  
⊖ 3/32" (2.4 mm) SLOTTED SCREW DRIVER FOR ADJUSTMENTS IN THE SIGNAL TERMINALS;  
⊕ #1 PHILLIPS SCREW DRIVER FOR ADJUSTMENTS IN THE POWER TERMINALS.

### 90~240Vac connection

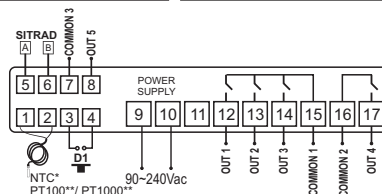

### 12 Vac/dc connection

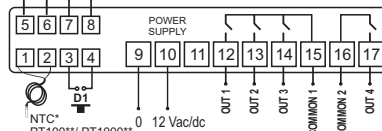

### 24 Vac/dc connection

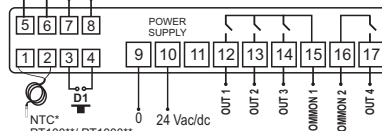

\*\* This sensor is sold separately.

## 6. OPERATIONS

### 6.1. Quick Access Menu Map

To access or browse the quick access menu, use the **A** key (quick touch) while the temperature is being displayed by the controller. With each touch the next function in the list is displayed. To confirm use the **SET** key (quick touch). See chapter 6.3 for more details. The map of functions is shown below:

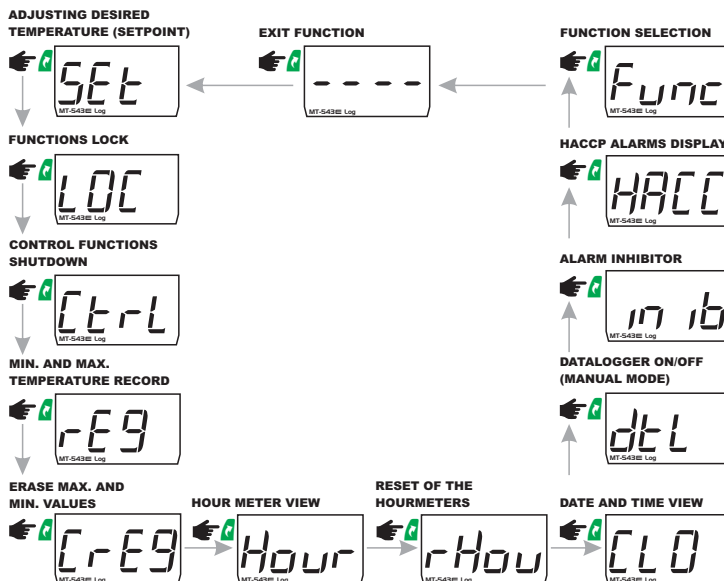

### 6.2. Quick access keys map

When controller is on temperature display mode, the following keys can be used as shortcuts for the following functions:

<b>SET</b>	Hold down for 2 seconds: Setpoint adjustment.
<b>SET</b>	Quick touch: day/month/year/hour/minute.

	<b>Quick touch:</b> If working in rotation mode, displays the operating time of the refrigeration outputs.
	<b>Hold down for 2 seconds:</b> Inhibits the audible alarm and alarm output.
	<b>Quick touch:</b> Maximum and minimum temperature display.
	<b>Hold down for 2 seconds:</b> clear history when records are being displayed.
	<b>Hold down for 10 seconds:</b> manual datalogger activation.
	<b>Hold down for 2 seconds:</b> HACCP menu.
	<b>Held down simultaneously:</b> enter the function menu.

### 6.3 Basic operations

#### 6.3.1 Operation mode

This controller operates in two different modes:

**Basic mode:** it has 45 functions and datalogger features.

**Advanced mode:** has 61 functions, 1 datalogger, digital input, hourmeter, HACCP, and rotation control mode.

To select the controller's operating mode, access function F01 on menu  $[F01]$ .

**NOTE:** The features of the advanced mode will be disabled when the controller is configured to operate in the basic mode (F01=0).

**NOTE 2:** The features described in items 6.3.9, 6.3.16 and 6.3.17 will only be available when the controller is configured to operate in advanced mode (F01=1).

#### 6.3.2 Selection of the type of sensor

It is required when you want to change the type of sensor connected to the controller. You can choose the NTC thermistor, PT100\* or Pt1000\*. To define the type of sensor, press  $\Delta$  and  $\nabla$  simultaneously (quick touch) when the temperature is being displayed, enter the option  $[CODE]$  using the access code  $[312]$  and then press  $\nabla$ . The message  $[SEN5]$ , will be displayed, then select the desired sensor type  $[NTC]$  (thermistor NTC) or  $[PT100]$  (thermistor PT100\*) or  $[PT1000]$  (thermistor Pt1000\*) using the  $\Delta$  or  $\nabla$  keys, and press  $\nabla$  to confirm. Whenever the type of sensor is changed, the configuration of the functions assumes the factory default, so they need to be configured again.

#### 6.3.3 Sensor Connection

The NTC, PT100\*, or PT1000\* sensors must be connected according to the picture below:

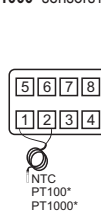

\*This sensor is sold separately.

Table of wire gauge / max distance for the two wire PT100\*.

	Diameter (AWG) (mm)	Máx. dist. (meters)
14	1.63	18.1
16	1.29	11.4
18	1.02	7.2
20	0.81	3.0
22	0.64	1.9
24	0.51	1.8
26	0.40	1.1

#### 6.3.4 Selection of units

To select the units the system will use to operate, press  $\Delta$  and  $\nabla$  simultaneously while the temperature is being displayed, enter the option  $[CODE]$  using the access code  $[231]$  and then press  $\nabla$ . Then select the desired unit  $[C]$  or  $[F]$  using the  $\Delta$  or  $\nabla$  key, and press  $\nabla$  to confirm. Whenever the units are changed, the functions' configuration assumes the factory default, so they need to be configured again.

#### 6.3.5 Adjusting the desired temperature (Setpoint)

To enter the setpoint adjustment menu, press  $\nabla$  for 2 seconds until  $[SET]$  is displayed or use the quick access menu key. The message  $[SP1]$  and then the value to adjust the setpoint of **stage 1** will be displayed in sequence. Use the  $\Delta$  or  $\nabla$  keys to change the value and press  $\nabla$  to confirm.

- If **stage 2** is configured to operate as refrigeration controlled by SP2 (F08=0) or heating controlled by SP2 (F08=1), the message  $[SP2]$  will be displayed afterwards. Use the  $\Delta$  or  $\nabla$  keys again to change the value and press  $\nabla$  to confirm.

- If **stage 3** is configured to operate as refrigeration controlled by SP3 (F13=0) or heating controlled by SP3 (F13=1), the message  $[SP3]$  will be displayed afterwards. Use the  $\Delta$  or  $\nabla$  keys again to change the value and press  $\nabla$  to confirm.

- If **stage 4** is configured to operate as refrigeration controlled by SP4 (F30=0) or heating controlled by SP4 (F30=1), the message  $[SP4]$  will be displayed afterwards. Use the  $\Delta$  or  $\nabla$  keys again to change the value and press  $\nabla$  to confirm.

If the **3rd stage** is configured as a cyclical timer (F13 = 2) or minimum ventilation (F13 = 3), the adjustment of the time of the cyclical timer of the 3rd stage on  $[C0N]$  and the time of the cyclical timer of the 3rd stage off  $[OFF]$  will be possible. The adjustment of alarm on  $[E0N]$  and off  $[OFF]$  times will be allowed if stage 4 is configured as alarm (F30 = 2, 3, or 4). Finally, the message  $[---$ ] indicates that the configuration is complete.

#### 6.3.6 Functions lock

The use of the lock function brings greater security to the operation of the instrument. The setpoint and other parameters can be visible to the user when active, but they are protected against undue changes (F42=2) or only block changes to the control functions and leave the adjustment of the setpoint enabled (F42=1). To activate the functions lock, access  $[LOCK]$  in the quick access menu. The message  $[LOP]$  (lock must be enabled and deactivated) will be displayed. When the message is being displayed, press and hold  $\nabla$  for the time configured in (F43) for the functions to be locked. The activation will be indicated by the message  $[LOCK]$ . To enable the use of this function, F42 must be configured with 1 or 2. The message  $[LOCK]$  that is displayed when trying to change any parameter indicates that functions lock is active. To deactivate it, switch the controller off and on again with the  $\nabla$  key held down. Keep the key held down until the  $[LOCK]$   $[OFF]$  message indicates the unlocking (10 seconds).

#### 6.3.7 Control functions shutdown

Turning the control functions off allows for the controller to operate just as an indicator of temperature, keeping the control outputs and the alarms disconnected. Use of this feature is enabled or disabled by the control functions shutdown (F44) function. When enabled, the control and alarms functions are turned off  $([CTRL]$   $[OFF])$  or on  $([CTRL]$   $[ON])$  through the quick access menu in the option  $[CTRL]$ . When the control functions are off the message  $[OFF]$  will then be displayed alternately with the temperature and the other messages.

#### 6.3.8 Minimum and maximum temperature record

The display of minimum and maximum temperature records can be checked through the quick access menu or by pressing the  $\Delta$  key. The minimum and maximum temperatures recorded will be displayed in sequence. To erase the minimum and maximum values recorded, keep the  $\Delta$  key pressed for 2 seconds while the records are being displayed or use the option  $[ERE]$  in the quick access menu. The message  $[SEE]$  indicates that the records were erased.

#### 6.3.9 Hourmeter

The hourmeter indicates the number of working hours for the outputs configured as heating / refrigeration. The hourmeter can be viewed through the quick access menu  $(\Delta)$  in the option  $[HOUR]$  and the working time of each output is displayed in hours. The maximum working time of the output for maintenance purposes can be configured through function F57. When the compressor's number of working hours reaches the value configured in this function an alert will be displayed  $[Hn1]$  for output 1,  $[Hn2]$  for output 2,  $[Hn3]$  for output 3 or  $[Hn4]$  for output 4, indicating that maintenance is due for the corresponding output.

To disable the alert or reset the hourmeter counter, access option  $[HOU]$  in the quick access menu  $(\Delta)$ , sing the  $\Delta$  or  $\nabla$  keys to select the hourmeter to reset  $([OUT1]$ ,  $[OUT2]$ ,  $[OUT3]$  or  $[OUT4])$  and then press  $\nabla$ . The message  $[SET1]$ ,  $[SET2]$ ,  $[SET3]$  or  $[SET4]$  will be displayed depending on the output chosen.

#### 6.3.10 Operation time of the outputs in rotation mode

Pressing the  $\nabla$  key in the rotation (F46=1, 2 or 3) mode the following will be shown:

$[ETE1]$  and then the total accumulated time in hours for OUT1

$[ETE2]$  and then the total accumulated time in hours for OUT2

$[ETE3]$  and then the total accumulated time in hours for OUT3

$[ETE4]$  and then the total accumulated time in hours for OUT4

Then the message  $[AET1]$ ,  $[AET2]$ ,  $[AET3]$  or  $[AET4]$  will be displayed depending on the current active output, and then the time remaining for the output change will be displayed.

**NOTE:** The total time of OUT3  $[ETE3]$  will only be displayed if F46=2 or 3 and the total time of OUT4  $[ETE4]$  will only be displayed if F46=3.

#### Resetting of the time for rotation and selection of the current output:

If the  $\nabla$  key is pressed and kept held down while the time is being displayed, the times are reset at the end of the display. Once this is done, the message  $[SEE]$  will be displayed and then  $[OUT1]$ ,  $[OUT2]$ ,  $[OUT3]$  or  $[OUT4]$ , indicating which output will be the first to be activated. Every time the times are reset, the action goes to the next output.

#### 6.3.11 View current date and time

Quickly pressing the  $\nabla$  key (quick touch) makes it possible to view the current date and time set in the controller. The current day  $(--d)$ , month  $(--M)$ , year  $(--Y)$ , hour and minute  $(HH:MM)$  will be shown in sequence on the display. It is also possible to view the date and time through the quick access menu in the option  $[LTH]$ .

**NOTE:** The number beside the message day indicates the day of the week.

**Example:**  $[dMY]$  is Sunday.

#### 6.3.12 Manual datalogger activation

The manual activation of the internal record of temperature values and state of outputs (Datalogger) is performed through the quick access menu in the option  $[DEL]$ . The message  $[DEL]$  will be displayed followed by the message  $[ON]$  when the datalogger is activated or  $[OFF]$  when it is deactivated. It is also possible to activate the datalogger manually by pressing the  $\Delta$  and  $\nabla$  keys for 10 seconds.

#### 6.3.13 Audible alarm and alarm output inhibitor

To inhibit the alarm output OUT4 and / or the audible alarm (buzzer), when they are active, press  $\nabla$  for 2 seconds. In this case, if OUT4 and buzzer are active, they will both be inhibited.

It is also possible to inhibit the alarm or buzzer through the option  $[INB]$  in the quick access menu  $\Delta$ , where it is possible to choose the individual alarm to be inhibited  $([OUT4]$  or  $[BUZ2])$  using the  $\Delta$  or  $\nabla$  keys and pressing  $\nabla$ .

#### 6.3.14 Power failure alarm

Output OUT5 can be used as power failure alarm and / or alert. During the normal operation of the controller this output will remain deactivated and during a power failure it is activated and remains active until the power is restored and the controller resumes normal operation.

#### 6.3.15 Stages

**MT-543E Log** controller has four stages.

Stages 1 and 2 work only as refrigeration or heating.

Besides operating as refrigeration or heating, **Stage 3** can act as a cyclical timer or minimum ventilation. It has five operating modes when configured as cyclical timer:

- **Independent (F22=0):** the timer cycles are according to the times configured in F20  $([C0N])$  and F21  $([OFF])$ .

- **Timer triggered by SP1 (F22=1):** the timer is triggered whenever the temperature reaches the value configured for SP1. The timer switches off when the temperature reaches SP1 + F06 (if **stage 1** is configured as refrigeration) or SP1 - F06 (if **stage 1** is configured as heating), as shown in Figure 1.

- **Stage 1 linked to the cyclical timer (timer switches on upon power up) (F22=2):** in this configuration, the timer cycles according to the times configured in F20  $([C0N])$  and F21  $([OFF])$ . The **Stage 1** starts to cycle when the temperature reaches SP1 + F06 (if **stage 1** is configured as refrigeration) or SP1 - F06 (if **stage 1** is configured as heating), as shown in Figure 1.

- **Stage 1 linked to the cyclical timer (timer off upon power up) (F22=3):** The operation is similar to the previous configuration. The difference in this configuration is that the timer starts off.
- **Cyclical timer output is on whenever stage 1 output is on (F22=4):** in this operating mode timer cycles according to the times configured in F20 ( $\overline{[T \theta n]}$ ) and F21 ( $\overline{[T \theta F F]}$ ), and **stage 3** stops cycling and keeps the output switched on, whenever **stage 1** output switches on, as shown in Figure 3.
- **Cyclical timer output cycles whenever stage 1 output is on (F22=5):** **stage 3** will cycle only when **stage 1** output is on, observing the times configured in F20 ( $\overline{[T \theta n]}$ ) and F21 ( $\overline{[T \theta F F]}$ ), as shown in Figure 4.

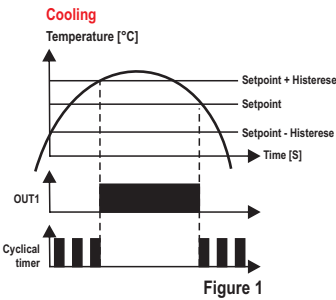

Figure 1

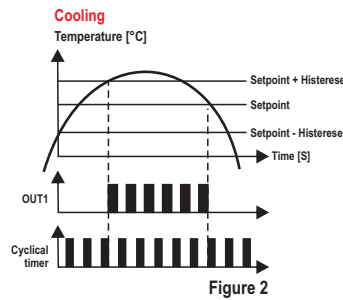

Figure 2

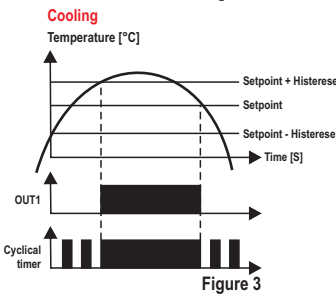

Figure 3

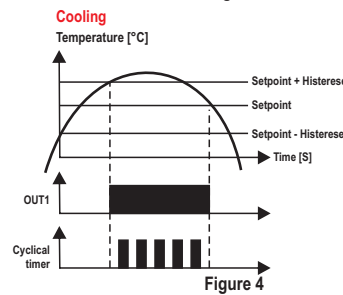

Figure 4

**Stage 3** configured as minimum ventilation; it will act together with **stage 1** (configured for heating) in systems that require minimum ventilation. Functioning as follows: when the temperature is between SP1 and SP1-F06 or between SP1 and SP1+F16, **stage 3** will cycle according to the times configured in F20 ( $\overline{[T \theta n]}$ ) and F21 ( $\overline{[T \theta F F]}$ ). If the temperature is below SP1-F06, the ventilation is switched off, and if the temperature is higher than SP1+F16, the ventilation remains on, and stays in this condition until it reaches the setpoint again, as shown in Figure 5.

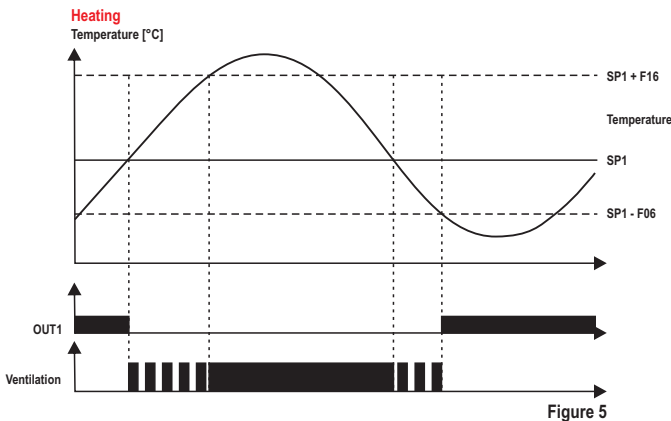

Figure 5

Like in the previous stages, **stage 4** can also be configured as refrigeration or heating. It can also act as an in-range, out-of-range, and relative out-of-range alarm (F30 = 2, 3, and 4). All stages can operate as refrigeration in rotation mode.

### 6.3.16 - Refrigeration in rotation

The rotation mode switches the output used for refrigeration, making each machine work during a certain time and therefore makes all of them accumulate the same working time. It also enables a logic of stages that activates the outputs simultaneously when the setpoint is not reached in normal operation (**1st stage**). However, as the outputs alternate in the rotation, there is not a link between the order of stages and outputs. Thus, when entering the second stage one more output is activated, which can be OUT1, OUT2, OUT3 and OUT4.

To use the "Rotation" function, F46 (Stage control mode) must be adjusted to indicate the outputs that will activate. To enable the rotation, the operating mode of the **2nd stage** (F08) is automatically forced to the rotation function. The same happens with the mode of operation of the **3rd stage** if the rotation uses the three outputs (F46 = 2). If the controller is configured to use rotation in all four stages (F46=3), the operating mode of **stage 4** (F30) is automatically forced into the rotation function. In normal operation, when the temperature exceeds the control differential of the **1st stage**, the output with less working time (OUT1, OUT2, OUT3 or OUT4) is activated to engage refrigeration. The time it remains switched on to reach the setpoint is accumulated. When the accumulated value of the on time of the output exceeds a given number of hours, it gives way to the next output. This time during which the rotation will be performed is configured in hours in function F47 (time for rotation operation), the setpoint is set in the quick access menu (SP1) or in the function F53, and the control differential of the **1st stage** is adjusted in F06.

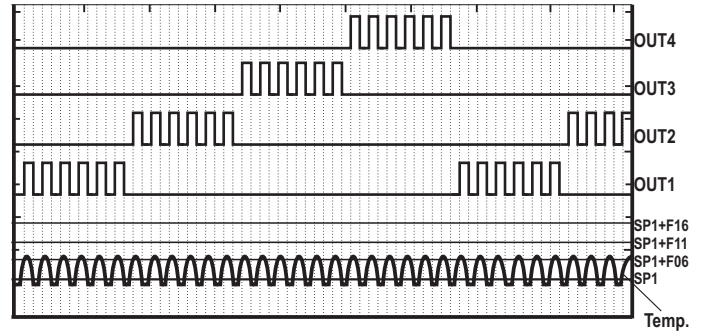

When due to any failure the active output cannot reach the setpoint, the **2nd, 3rd and 4th stages** act as backup. Two criteria are used to determine this operation for each stage, temperature differential and time. In the first case, new control outputs will be activated as the temperature deviates from the setpoint and exceeds the control differentials of each stage. In this way, all outputs may work together. The differentials to include a new output are defined in relation to the setpoint (SP1) and configured in F11, control differential of the **2nd stage**, and in F16, control differential of the **3rd stage**, and in F33, control differential of the **4th stage**.

For the **2nd, 3rd and 4th stages** to act by time, the time is counted from the activation of the current output of the **1st stage**. If that time exceeds a certain limit (F48) without reaching the setpoint, the **2nd stage** activates the output with less accumulated time. The time count is restarted and if that limit is exceeded again without reaching the setpoint, **stage 3** activates the next output with less accumulated time and restarts the time count. If this given limit is exceeded again, the remaining output is activated. The time to activate a new output is configured in minutes in F48.

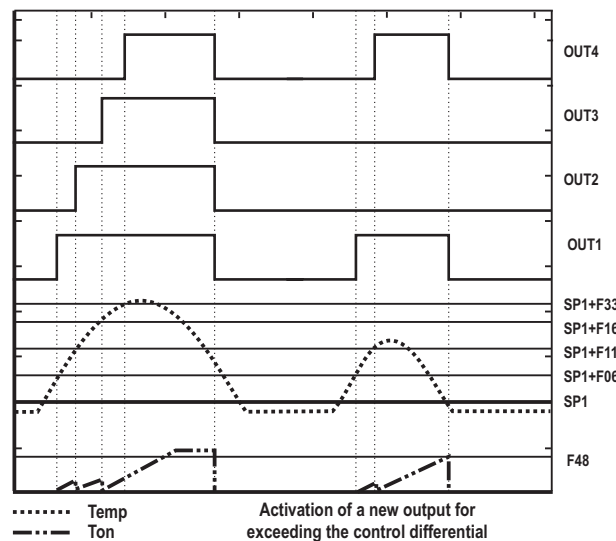

Activation of a new output for exceeding the control differential

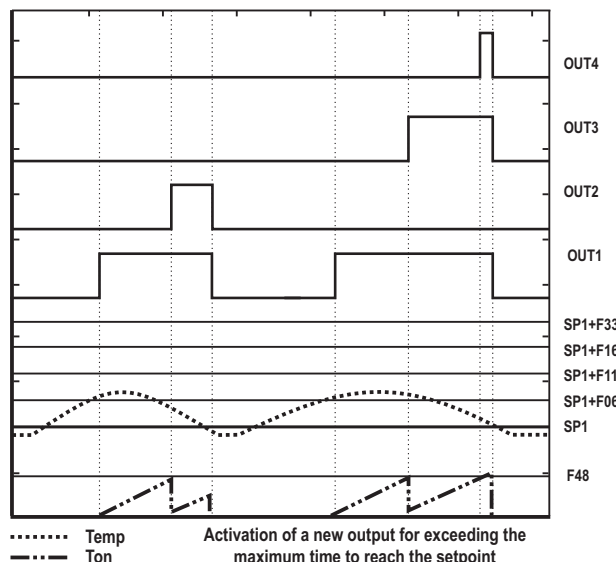

Activation of a new output for exceeding the maximum time to reach the setpoint

The buzzer may be activated when more than one output is activated simultaneously (**2nd, 3rd and 4th stages**). To do this, F23 (buzzer operation mode) must be defined as 3 - Error alarm in the rotation mode.

Also related to protection routines, it is possible to set the minimum time between the stage switch off the output and switch it on again, configured in F07, F12, F17 and F34, minimum delay to switch on again the outputs of the **1st, 2nd, 3rd and 4th stages** respectively. There is also a logic to prevent the outputs from switching on at the same time by forcing a time interval between activations, which is configured in F49.

### 6.3.17 - HACCP

This controller helps food industry management systems by allowing monitoring of the critical control points required by HACCP (Hazard Analysis and Critical Control Points) regulations. Up to 24 records of the following types are maintained: high temperature, low temperature, digital input, and power failure.

### High temperature alarm [ALHi]

During operation, when a temperature exceeding the value configured in F60 (HACCP - High temperature alarm) is identified and stays above this value for a time exceeding the value configured in F61 (Alarm validation time), an [ALHi] type record is created. In this case, the information stored is: alarm start's date and time, alarm duration, and maximum temperature measured during the alarm condition.

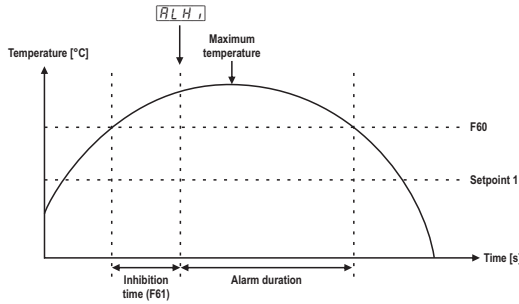

### Low temperature alarm [ALLo]

During operation, when a temperature below the value configured in F60 (HACCP - Low temperature alarm) is identified and stays below this value for a time exceeding the value configured in F61 (Alarm validation time), a [ALLo] type record is created. In this case, the information stored is: alarm start date and time, alarm duration, and minimum temperature measured during the alarm condition.

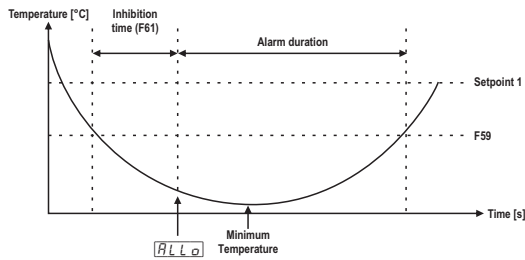

### Digital input alarm [ALIn]

When the door open alarm is enabled (F52) and is activated, a [ALIn] type record will be carried out. In this case, the information stored is: alarm start date and time, alarm duration, and maximum temperature measured during the alarm condition.

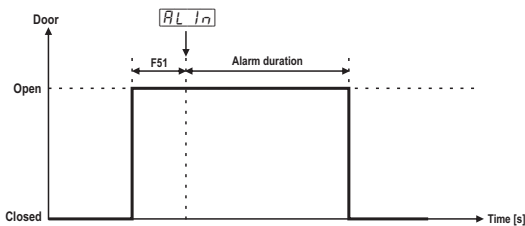

### Power failure alarm [ALNo]

If there is a power failure and the controller stays off for more than 1 minute, when the power is restored and the controller presents a temperature exceeding the value configured in F60 (HACCP - High temperature alarm), a [ALNo] type record will be immediately created. In this case, the information stored is: power restoration date and time, and temperature measured at the moment the controller is switched on again.

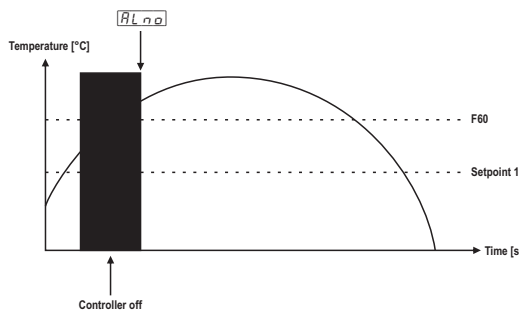

Up to six records for each type of alarm are stored. If the number of records stored exceeds this number, the least recent record is replaced for each new alarm.

The HACCP alarms display must be made in [HACCL] in the main menu or in the quick access menu (A). The [HACCL] menu is divided in accordance with the type of alarm:

[ALHi]: where the high temperature records are;

[ALLo]: low temperature records;

[ALIn]: digital input records;

[ALNo]: power failure records.

Follow the steps below to view the records:

- Select option [HACCL] in the main menu and press [SET].
- Choose the type of alarm to be viewed [ALHi], [ALLo], [ALIn] or [ALNo] using the buttons [▲] or [▼] and press [SET].
- The controller stores up to six records for each type of alarm, use the buttons [▲] or [▼] the number of the record to be viewed and press [SET].

d) In [ALHi], [ALLo] and [ALIn] type alarms, the following data will be displayed in sequence: alarm start date and time (---d ---m ---y 00:00), alarm duration (5EAY 00:00) maximum / minimum temperature measured during the alarm.

e) In [ALNo] type alarms, the following data will be displayed in sequence: alarm start date and time (---d ---m ---y 00:00) and temperature measured at the moment power is restored.

f) If there are no records stored in the chosen option, the message [NoP] will be displayed.

g) After displaying the alarm data, the controller returns to the HACCP alarm display menu.

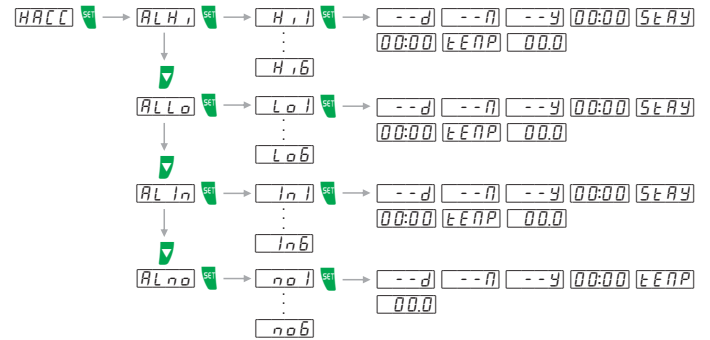

**NOTE:** Keep the button [SET] held down to return to the previous menu page.

**NOTE 2:** The alarm duration time and maximum temperature measured can be updated while the alarm is occurring.

Follow the steps below to erase all HACCP alarm records:

- Go to the main function menu pressing [▲] and [▼] (quick touch) simultaneously while the temperature is displayed.
- Select the menu option [CoDE] and press [SET].
- Using the [▲] or [▼] keys enter the access code 123 (one hundred and twenty-three) and confirm with [SET].
- Using the [▲] or [▼] keys again, enter the [HACCL] menu, select option [HrSE] and press [SET].
- If you are sure you want to erase the HACCP records permanently and the code was entered correctly, use the [▲] or [▼] keys, select option [yEE] and press [SET].
- The message [rSE] will be displayed and all HACCP records will be erased. From this moment on, any newly generated HACCP alarm will be stored in position 1 of the alarm category to which it belongs.

### HACCP Signaling

When a new HACCP alarm occurs, the indication (▲) in the display will be lit. The indication will only go dark after the alarm is viewed in the [HACCL] menu.

For easy viewing of the new HACCP alarms, the dot in the lower right corner of the alarm type will be lit, indicating which alarms have not yet been displayed, as shown in the figure below.

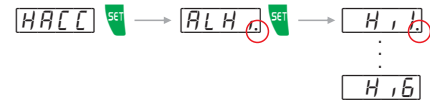

## 6.4 Advanced Operations

### 6.4.1 Access to the main menu

The main menu can be accessed through the quick access menu, option [Func] or by pressing [▲] and [▼] simultaneously (quick touch) while the temperature is being displayed.

The following options will be displayed:

- [CoDE] - Entry to the access code
- [Func] - Change the parameters
- [LoG] - Datalogger functions
- [LiD] - Adjustment or visualization of the date and time
- [HACCL] - Display of the HACCP alarms

### 6.4.2 Access Code

To change the parameters or adjust the clock, select the [CoDE] option by pressing [SET] (quick touch) and entering the access code 123 (one hundred and twenty-three) using the [▲] or [▼] key, and confirm with [SET].

### 6.4.3 Changing the controller parameters

In the main menu, enter the option [Func] and select the desired function using the [▲] or [▼] keys. Press [SET] (quick touch) after selecting the function to view its value. Use [▲] or [▼] to change the value and press [SET] when ready to save the configured value and return to the functions menu. To leave the menu and return to the normal operating mode (temperature indication), hold down [SET] (long touch) until [---] appears.

**NOTE:** If the functions lock is active, the controller will show the message [LoL] in the display upon pressing [▲] or [▼] and will not allow adjusting the parameters.

### 6.4.4 Date and time adjustment

Select the option [LiD] in the main menu. The controller will enter the date and time adjustment mode if the access code [123] was correctly entered. Use [▲] or [▼] to change the value and press [SET] when ready to save the configured value. If the date entered is invalid, the message [ECLD] will be shown on the display.

**▲ IMPORTANT:** The controller has an auxiliary internal power supply to keep the clock running in case of power failure. If the controller remains off for a long period of time, the message [ECLD] will be displayed to indicate that the clock is not programmed. In this case, the date and time must be adjusted and the controller must be kept on for 24 hours to fully recharge the auxiliary power supply.

### 6.4.5 Internal datalogger

When the datalogger is enabled (F62), it is possible to store records in the controller's internal memory. It can be configured to store records by time interval (F63), by temperature variation (F64), and/or by the variation of the state of the digital output or inputs (F65). The activation of alarms also performs the storage of records. The information contained in a record are: temperature, state of the outputs, state of the door, alarms and record creation timestamp.

**NOTE:** No records are stored in the datalogger if the clock is not programmed.

### 6.4.6 Data recording during power failure

With the datalogger active (F62), **MT-543E Log** keeps recording the temperature in the memory even during an electric power failure. For safety reasons, the recordings will be performed at a fixed interval of 1 minute, regardless of the time interval (F63), temperature variation (F64) or variations in the state of the digital input or outputs (F65). The average autonomy of the internal device for fully charged energy storage, in this condition, is approximately 24 hours.

### 6.5 Parameters table

Fun	Description	NTC								PT100/PT1000*							
		CELSIUS				FAHRENHEIT				CELSIUS				FAHRENHEIT			
		Min	Max	Unit	Standard	Min	Max	Unit	Standard	Min	Max	Unit	Standard	Min	Max	Unit	Standard
F01	Controller's operating mode	0	1	-	0	0	1	-	0	0	1	-	0	0	1	-	0
F02	Indication offset	-20	20	°C	0	-36	36	°F	0	-50	50	°C	0	-90	90	°F	0
F03	Stage 1 operating mode	0	1	-	1	0	1	-	1	0	1	-	1	0	1	-	1
F04	Minimum setpoint allowed (stage 1)	-50	200	°C	-50	-58	392	°F	-58	-200	300	°C	-200	-328	572	°F	-146
F05	Maximum setpoint allowed (stage 1)	-50	200	°C	105	-58	392	°F	221	-200	300	°C	300	-328	572	°F	572
F06	Stage 1 control differential (hysteresis)	0.1	20	°C	1	1	36	°F	2	1	50	°C	2	2	90	°F	4
F07	Minimum delay to switch on stage 1 output again	0	999	sec.	0	0	999	sec.	0	0	999	sec.	0	0	999	sec.	0
F08	Stage 2 operating mode	0	4	-	0	0	4	-	0	0	4	-	0	0	4	-	0
F09	Minimum setpoint allowed (stage 2)	-50	200	°C	-50	-58	392	°F	-58	-200	300	°C	-200	-328	572	°F	-328
F10	Maximum setpoint allowed (stage 2)	-50	200	°C	105	-58	392	°F	221	-200	300	°C	300	-328	572	°F	572
F11	Stage 2 control differential (hysteresis)	0.1	20	°C	1	1	36	°F	2	1	50	°C	2	2	90	°F	4
F12	Minimum delay to switch on stage 2 output again	0	999	sec.	0	0	999	sec.	0	0	999	sec.	0	0	999	sec.	0
F13	Stage 3 operating mode	0	6	-	0	0	6	-	0	0	6	-	0	0	6	-	0
F14	Minimum setpoint allowed (stage 3)	-50	200	°C	-50	-58	392	°F	-58	-200	300	°C	-200	-328	572	°F	-328
F15	Maximum setpoint allowed (stage 3)	-50	200	°C	105	-58	392	°F	221	-200	300	°C	300	-328	572	°F	572
F16	Stage 3 control differential (hysteresis)	0.1	20	°C	1	1	36	°F	2	1	50	°C	2	2	90	°F	4
F17	Minimum delay to switch on stage 3 output again	0	999	sec.	0	0	999	sec.	0	0	999	sec.	0	0	999	sec.	0
F18	Stage 3 cyclical timer time base	0	1	-	0	0	1	-	0	0	1	-	0	0	1	-	0
F19	Time to activate stage 3 cyclical timer	0	999	sec.	5	0	999	sec.	5	0	999	sec.	5	0	999	sec.	5
F20	Time of cyclical timer of stage 3 on	0	999	s/m	0	0	999	s/m	0	0	999	s/m	0	0	999	s/m	0
F21	Time of cyclical timer of stage 3 off	0	999	s/m	0	0	999	s/m	0	0	999	s/m	0	0	999	s/m	0
F22	Cyclical timer operating mode	0	5	-	0	0	5	-	0	0	5	-	0	0	5	-	0
F23	Buzzer operating mode	0	3	-	1	0	3	-	1	0	3	-	1	0	3	-	1
F24	Buzzer operating point (lower threshold)	-50	200	°C	-50	-58	392	°F	-58	-200	300	°C	-200	-328	572	°F	-328
F25	Buzzer operating point (upper threshold)	-50	200	°C	105	-58	392	°F	221	-200	300	°C	300	-328	572	°F	572
F26	Buzzer on time	0	999	sec.	1	0	999	sec.	1	0	999	sec.	1	0	999	sec.	1
F27	Buzzer off time	0	999	sec.	1	0	999	sec.	1	0	999	sec.	1	0	999	sec.	1
F28	Buzzer Alarm inhibition time upon power up	0	999	Min.	0	0	999	Min.	0	0	999	Min.	0	0	999	Min.	0
F29	Time to reactivate the buzzer when manually inhibited	Auto	999	Min.	Auto	Auto	999	Min.	Auto	Auto	999	Min.	Auto	Auto	999	Min.	Auto
F30	Stage 4 operating mode	0	7	-	3	0	7	-	3	0	7	-	3	0	7	-	3
F31	Minimum setpoint allowed (stage 4)	-50	200	°C	21	-58	392	°F	70	-200	300	°C	21	-328	572	°F	70
F32	Maximum setpoint allowed (stage 4)	-50	200	°C	27	-58	392	°F	81	-200	300	°C	27	-328	572	°F	81
F33	Stage 4 control differential (hysteresis)	0.1	20	°C	1	1	36	°F	2	1	50	°C	2	2	90	°F	4
F34	Minimum delay to switch on stage 4 output again	0	999	sec.	0	0	999	sec.	0	0	999	sec.	0	0	999	sec.	0
F35	Alarm inhibition time upon power up	0	999	Min.	0	0	999	Min.	0	0	999	Min.	0	0	999	Min.	0
F36	Time to reactivate the alarm when manually inhibited	Auto	999	Min.	Auto	Auto	999	Min.	Auto	Auto	999	Min.	Auto	Auto	999	Min.	Auto
F37	Alarm on time	0	999	sec.	1	0	999	sec.	1	0	999	sec.	1	0	999	sec.	1
F38	Alarm off time	0	999	sec.	1	0	999	sec.	1	0	999	sec.	1	0	999	sec.	1
F39	Alarm inhibition time (delay)	0(NO)	999	Min.	0(NO)	0(NO)	999	Min.	0(NO)	0(NO)	999	Min.	0(NO)	0(NO)	999	Min.	0(NO)
F40	Digital filter operating mode	0	1	-	0	0	1	-	0	0	1	-	0	0	1	-	0
F41	Digital filter intensity applied to the sensor	0	20	sec.	0	0	20	sec.	0	0	20	sec.	0	0	20	sec.	0
F42	Functions Lock	0	2	-	0	0	2	-	0	0	2	-	0	0	2	-	0
F43	Time for functions lock	15	60	sec.	15	15	60	sec.	15	15	60	sec.	15	15	60	sec.	15
F44	Control Functions Shutdown	0(NO)	2	-	0(NO)	0(NO)	2	-	0(NO)	0(NO)	2	-	0(NO)	0(NO)	2	-	0(NO)
F45	RS-485 network address	1	247	-	1	1	247	-	1	1	247	-	1	1	247	-	1

### Advanced function menu (displayed if F01=1)

Fun	Description	NTC								PT100/PT1000*							
		CELSIUS				FAHRENHEIT				CELSIUS				FAHRENHEIT			
		Min	Max	Unit	Standard	Min	Max	Unit	Standard	Min	Max	Unit	Standard	Min	Max	Unit	Standard
F46	Stage control mode	0	3	-	0	0	3	-	0	0	3	-	0	0	3	-	0
F47	Time for rotation operation	1	999	h	1	1	999	h	1	1	999	h	1	1	999	h	1
F48	Maximum time to activate a new output	1	999	Min.	12	1	999	Min.	12	1	999	Min.	12	1	999	Min.	12
F49	Minimum time between activations of relays	0	999	sec.	1	0	999	sec.	1	0	999	sec.	1	0	999	sec.	1
F50	Time base for door open alarm	0	1	-	0	0	1	-	0	0	1	-	0	0	1	-	0
F51	Time to alarm for door open	OFF	999	s/m	5	OFF	999	s/m	5	OFF	999	s/m	5	OFF	999	s/m	5
F52	Digital input operating mode	0	3	-	0	0	3	-	0	0	3	-	0	0	3	-	0
F53	Setpoint 1	-50	200	°C	23	-58	392	°F	73	-200	300	°C	23	-328	572	°F	73
F54	Setpoint 2	-50	200	°C	24	-58	392	°F	75	-200	300	°C	24	-328	572	°F	75
F55	Setpoint 3	-50	200	°C	25	-58	392	°F	77	-200	300	°C	25	-328	572	°F	77
F56	Setpoint 4	-50	200	°C	26	-58	392	°F	79	-200	300	°C	26	-328	572	°F	79
F57	Maximum operating time of the output for maintenance	0(NO)	999	x10h	500	0(NO)	999	x10h	500	0(NO)	999	x10h	500	0(NO)	999	x10h	500
F58	Enable HACCP alarm records	0	1	-	0	0	1	-	0	0	1	-	0	0	1	-	0
F59	HACCP - Low temperature alarm	-50	200	°C	-50	-58	392	°F	-58	-200	300	°C	-99	-328	572	°F	-146
F60	HACCP - High temperature alarm	-50	200	°C	105	-58	392	°F	221	-200	300	°C	300	-328	572	°F	572
F61	HACCP - Alarm inhibition time	0(NO)	999	Min.	0(NO)	0(NO)	999	Min.	0(NO)	0(NO)	999	Min.	0(NO)	0(NO)	999	Min.	0(NO)

Caption: [n 0] = no [H u E 0] = automatic

\* This sensor is sold separately.

## 6.5.1 Description of the parameters

### F01 - Controller's operating mode:

Configures if the controller operates in the basic mode (45 functions) or in the advanced mode (61 functions):

- 0 - Basic mode
- 1 - Advanced mode

**NOTE:** The features of the advanced mode will be disabled when the controller is in the basic mode.

### F02 - Indication offset:

Allows for the compensation of possible deviations in the temperature reading caused by the replacement of the sensor or changes in the cable length.

### F03 - Stage 1 operating mode:

- 0 - Refrigeration
- 1 - Heating

### F04 - Minimum setpoint allowed to the end user (1st stage):

Electronic backstop aimed to prevent an exceedingly low temperature being inadvertently adjusted in the setpoint.

### F05 - Maximum setpoint allowed to the end user (1st stage):

Electronic backstop aimed to prevent an exceedingly high temperature being inadvertently adjusted in the setpoint.

### F06 - Stage 1 control differential (hysteresis):

It is the temperature difference (hysteresis) between switching output OUT1 ON and OFF.

### F07 - Minimum delay to switch on stage 1 output again:

It is the minimum time the OUT1 output will remain off, i.e. the length of time between the last stop and the next start up.

### F08 - Stage 2 operating mode:

- 0 - Refrigeration (controlled by SP2)
- 1 - Heating (controlled by SP2)
- 2 - Refrigeration (controlled by SP1)
- 3 - Heating (controlled by SP1)
- 4 - 2nd stage of the refrigeration in rotation (controlled by SP1)

### F09 - Minimum setpoint allowed for the end user (2nd stage):

### F10 - Maximum setpoint allowed for the end user (2nd stage):

Electronic backstop aimed to prevent exceedingly low or high temperatures being inadvertently adjusted in the setpoint.

### F11 - Stage 2 control differential (hysteresis):

It is the temperature difference (hysteresis) between switching output OUT2 ON and OFF.

### F12 - Minimum delay to switch on stage 2 output again:

It is the minimum time the OUT2 output will remain off, i.e. the length of time between the last stop and the next start up.

### F13 - Stage 3 operating mode:

- 0 - Refrigeration (controlled by SP3)
- 1 - Heating (controlled by SP3)
- 2 - Cyclical Timer
- 3 - Minimum ventilation
- 4 - Refrigeration (controlled by SP1)
- 5 - Heating (controlled by SP1)
- 6 - 3rd stage of the refrigeration in rotation (controlled by SP1)

**NOTE:** The operation of the minimum ventilation is described on item 6.3.15.

### F14 - Minimum setpoint allowed to the end user (3rd stage):

### F15 - Maximum setpoint allowed to the end user (3rd stage):

Electronic backstop to prevent exceedingly low or high temperatures being inadvertently adjusted in the setpoint.

### F16 - Stage 3 control differential (hysteresis):

It is the temperature difference (hysteresis) between switching output OUT3 ON and OFF.

### F17 - Minimum delay to switch on stage 3 output again:

It is the minimum time the OUT3 output will remain off, i.e. the length of time between the last stop and the next start up. Programmed only if F13=0, 1, 4, or 5.

### F18 - Stage 3 cyclical timer time base:

- 0 - Seconds
- 1 - Minutes

### F19 - Time to activate stage 3 cyclical timer:

This function depends on F22. Whenever the temperature reaches the value configured in  the time configured in this function is observed before activating the cyclical timer. To activate the timer at the moment  is reached, configure this function with 0.

### F20 - Time of cyclical timer of stage 3 on ():

Time for which the cyclical timer will remain active.

### F21 - Time of cyclical timer of stage 3 off ():

Time for which the cyclical timer will remain inactive.

### F22 - Cyclical timer operating mode:

- 0 - Independent cyclical timer
- 1 - Cyclical timer triggered by the stage 1 setpoint (SP1)
- 2 - Stage 1 linked to the cyclical timer (timer on upon power up)
- 3 - Stage 1 linked to the cyclical timer (timer off upon power up)
- 4 - Cyclical timer output is on whenever stage 1 output is on
- 5 - Cyclical timer output cycles whenever stage 1 output is on

### F23 - Audible alarm (buzzer) operating mode:

- 0 - In-range alarm (F24 e F25)
- 1 - Out-range alarm (F24 e F25)
- 2 - Out-of-range alarm related to the stage 1 setpoint ( - F24 and  +F25), the absolute values of F24 and F25 are considered.
- 3 - Rotation mode alarm (goes off when more than one output is activated).

### F24 - Buzzer operating point (lower threshold):

It is the lower temperature value for the buzzer alarm to activate according to F23.

### F25 - Buzzer operating point (upper threshold):

It is the higher temperature value for the buzzer alarm to activate according to F23.

### F26 - Buzzer on time:

It is the time the buzzer will remain on (active cycle). To disable the audible alarm (buzzer), configure this function with 0.

### F27 - Buzzer off time:

It is the time the buzzer will remain off (inactive cycle). To disable the audible alarm (buzzer), configure this function with 0.

### F28 - Buzzer Alarm inhibition time upon power up:

It is the time for which the buzzer will remain off, even in alarm conditions, for a certain period after initialization, since the system has not yet reached the working temperature.

### F29 - Time to reactivate the buzzer when manually inhibited:

This function allows for three different configurations:

0 - The buzzer will be inhibited until the temperature reaches the normal working condition and returns to the alarm condition again.

1 - Buzzer cannot be inhibited by the easy access keys.

2 to  9999 - Buzzer will be inhibited during this period (in minutes), switching on again if the alarm condition persists.

### F30 - Stage 4 operating mode:

- 0 - Refrigeration (controlled by SP4)
- 1 - Heating (controlled by SP4)
- 2 - In-range alarm (F31 and F32)
- 3 - Out-of-range alarm (F31 and F32)
- 4 - Out-of-range alarm related to the stage 1 setpoint ( - F31 and  + F32), the absolute values of F24 and F25 are considered.
- 5 - Refrigeration (controlled by SP1)
- 6 - Heating (controlled by SP1)
- 7 - 4th stage of the refrigeration in rotation (controlled by SP1)

### F31 - Minimum setpoint allowed to the end user (4th stage):

### F32 - Maximum setpoint allowed to the end user (4th stage):

Electronic backstop to prevent exceedingly low or high temperatures being inadvertently adjusted in the setpoint.

**NOTE:** When stage 4 is defined as alarm (F30=2, 3, or 4), the activation points are defined in F31 and F32.

### F33 - Stage 4 control differential (hysteresis):

It is the temperature difference (hysteresis) between switching output OUT4 ON and OFF.

### F34 - Minimum delay to switch on stage 4 output again:

It is the minimum time the OUT4 output will remain off, i.e. the length of time between the last stop and the next start up. Programmed only if F30=0, 1, 5, or 6.

### F35 - Alarm inhibition time upon power up:

This function serves to inhibit the alarm for a certain period after the start up, because the system has not yet reached the working temperature (only if F30=2, 3 or 4).

### F36 - Time to reactivate the alarm when manually inhibited:

This function allows for three different configurations (only if F30=2, 3, or 4):

0 - The alarm will be inhibited until the temperature reaches the normal working condition and returns to the alarm condition again.

1 - Alarm cannot be inhibited by the easy access keys.

2 to  9999 - Alarm will be inhibited during this period (in minutes), switching on again if the alarm condition persists.

### F37 - Alarm on time ():

To adjust the time output OUT4 will remain active (only if F30=2, 3, or 4).

### F38 - Alarm off time ():

To adjust the time output OUT4 will remain inactive (only if F30=2, 3, or 4). To always keep the alarm active configure this function with 0.

### F39 - Time to inhibit the alarms (delay):

When this configuration is active, the temperature must remain in the alarm condition for the defined inhibit time before the alarm is indicated. This allows avoiding warnings originating from punctual temperature variations. This configuration is used in the alarm output and in the audible alarm (buzzer).

### F40 - Digital filter operating mode:

- 0 - The filter operates both on the ascending and descending slope of the temperature.
- 1 - The filter operates only on the ascending slope of the temperature. When the temperature falls the response is immediate.

### F41 - Digital filter intensity:

The value adjusted in this function represents the time (in seconds) for the temperature to change by 0.1° C. This function can be switched off by setting it at the minimum value 0.

### F42 - Functions lock:

It allows and configures the functions lock (see item 6.3.6).

0 - Do not allow the functions lock.

1 - Allow a partial lock where the control functions will be locked but the adjustment of the setpoint is allowed.

2 - Allow full locking.

**NOTE:** The view of the minimum and maximum temperature records will always be allowed.

**F43 - Time for functions lock:**

It configures the time in seconds for the command to activate the functions lock:  
 to  - Time in seconds for the command to activate the lock.

**F44 - Control functions shutdown:**

Authorizes switching off the control functions (see item 6.3.7).  
 - Disables the control functions shutdown.  
 - Enables activation/deactivation of the control functions only if the functions are unlocked.  
 - Enables activation/deactivation of the control functions even if the functions are locked.

**F45 - Network address of the instrument RS-485:**

Equipment's network address for communicating with Sitrad software.  
**NOTE:** One network must not have different equipment with the same address.

**F46 - Stage control mode:**

It allows configuration for the operating mode of the stages, which can be normal or independent mode (F46=0) or rotation mode (F46=1, 2, or 3). The rotation mode switches the output used for refrigeration, making each machine work during a certain time and therefore makes all of them accumulate the same working time (SEE item 6.3.16).  
 - Disables refrigeration in rotation mode.  
 - Enables rotation for OUT1 and OUT2.  
 - Enables rotation for OUT1, OUT2 and OUT3.  
 - Enables rotation for OUT1, OUT2, OUT3 and OUT4.

**F47 - Time for rotation operation:**

to  - Time in hours for the rotation. When the current output accumulates this activated time, it is switched off and the next output with less accumulated time is switched on.  
**NOTE:** This function is only used if F46=1, 2, or 3.

**F48 - Maximum time to activate a new output:**

to  - Time in minutes to activate a new output. When the output of the first stage cannot reach the setpoint during this time another output is activated. If the rotation is enabled for the three or four outputs the time counting is restarted too. If the established limit is exceeded again, without the temperature reaching the setpoint, the next output is activated.

**F49 - Minimum time between activations of relays:**

- The relays will activate at the same time when required.  
 to  - Time in seconds between the activation of relays.  
 This configuration is disregarded when the output works as an alarm or cyclical timer.

**F50 - Time base for door open alarm:**

- Seconds  
 - Minutes

**F51 - Time for door open alarm:**

When the door open alarm is enabled, the buzzer will be activated after the door is left open for the programmed time. The time the buzzer will remain on and off for is configured in F26 and F27.  
 - Disabled.  
 to  - Time to activate the door open alarm.  
**NOTE:** It is also possible to link the door open alarm to the alarm output. For this, stage 4 must be configured as alarm (F30=2, 3, or 4) and F52=2 or 3.

**F52 - Digital input operating mode:**

Configure which state of the digital input indicates the door is open:  
 - Closed contact indicates that the door is open  
 - Open contact indicates that the door is open..  
 - Contact closed indicates that the door is open and links the door open alarm to the alarm output.  
 - Contact open indicates that the door is open and links the door open alarm to the alarm output.

**F53 - Stage 1 setpoint (SP1):**

Configures the desired temperature for stage 1.

**F54 - Stage 2 setpoint (SP2):**

Configures the desired temperature for stage 2.

**F55 - Stage 3 setpoint (SP3):**

Configures the desired temperature for stage 3.

**F56 - Stage 4 setpoint (SP4):**

Configures the desired temperature for stage 4.

**F57 - Maximum operating time of the outputs for maintenance:**

Whenever the outputs are active (except the output configured as alarm), the instrument will record the corresponding operating time. When this recorded time is equal to or higher than the time adjusted in this function, the message  will be displayed for output 1,  for output 2,  for output 3 or  for output 4, and the audible warning will also be activated, signaling that maintenance is due in the corresponding output.

**F58 - Enable HACCP alarm records:**

Enable HACCP alarm recording as described in item 6.3.17.  
 - Disable  
 - Enable

**F59 - HACCP - Low temperature alarm:**

It is the temperature below which the instrument will create a HACCP record type , as described in item 6.3.17. This configuration is used only for HACCP records; it does not generate an alarm in the alarm output and in the buzzer, because the values related to these specific alarms are configured in the respective functions.

**F60 - HACCP - High temperature alarm:**

It is the temperature over which the instrument will create a HACCP record type , as described in item 6.3.17. This configuration is used only for HACCP records, it does not generate an alarm in the alarm output and in the buzzer, because the values related to these specific alarms are configured in the respective functions.

**F61 - HACCP - Alarm validation time (delay):**

When this configuration is active, the temperature must remain in the HACCP alarm condition for the defined inhibition time before the alarm is indicated. This allows avoiding warnings originating from punctual temperature variations.  
 This configuration is only used for HACCP records.

**6.6 Log Menu**

The menu  contains the configuration functions of the internal datalogger.

Fun	Description	CELSIUS (°C)				FAHRENHEIT (°F)			
		Min	Max	Unit	Standard	Min	Max	Unit	Standard
<input type="text" value="F62"/>	Datalogger operating mode	0	2	-	2	0	2	-	2
<input type="text" value="F63"/>	Sampling time (time between records in the memory)	10	999	sec.	30	10	999	sec.	30
<input type="text" value="F64"/>	Minimum room temperature variation to force writing data to the memory	0(NO)	10	°C	0(NO)	18	°F	0(NO)	
<input type="text" value="F65"/>	Variation of the digital input or the outputs to force data writing	NO	YES	-	NO	NO	YES	-	NO
<input type="text" value="F66"/>	Overwrite old records when the memory is full?	NO	YES	-	YES	NO	YES	-	YES

**F62 - Datalogger operating mode:**

It allows choosing one of the following datalogger operating modes:  
 - Always off  
 - Always on  
 - Manual operation

**F63 - Sampling time (time between records in the memory):**

It is the time in seconds for which the controller records samples of the temperature information, state of the outputs, door status, and alarm status.

**F64 - Minimum temperature variation to force writing data to the memory:**

The temperature difference in relation to the last piece of data written in the datalogger for the data to be recorded in the memory regardless of the sampling time set in F63. To deactivate this function, just decrement the value until the message  is displayed.

**F65 - Variation of the digital input or the outputs to force data writing:**

It indicates whether changes in the digital input or in the control outputs (configured as refrigeration or heating) will force data to be written in the memory regardless of the sampling time set in F63. The data recording will also occur when the apparatus enters or leaves the alarm condition for OUT4 and buzzer, and upon power failure and power restoration.  
 - Off  
 - On

**F66 - Overwrite old records when the memory is full?:**

It indicates whether the controller should start writing new data at the beginning of the datalogger memory when the memory is full. This function prevents the last data calculated by the equipment from being lost. If set to zero, when the datalogger memory is full the instrument and Sitrad will signal full memory.

**7. SIGNALS**

<input type="text" value="Err"/>	Sensor disconnected or temperature outside specified range.
<input type="text" value="ECLD"/>	Invalid date and/or time (adjust the clock).
<input type="text" value="OPEN"/>	Open Door.
<input type="text" value="ADPN"/>	Open door alarm.
<input type="text" value="ADFL"/>	Datalogger memory full.
<input type="text" value="ENEN"/>	Contact Full Gauge.
<input type="text" value="OFF"/>	Control functions off.
<input type="text" value="ECLL"/>	Contact Full Gauge.
<input type="text" value="PPPP"/>	Reconfigure the functions values.

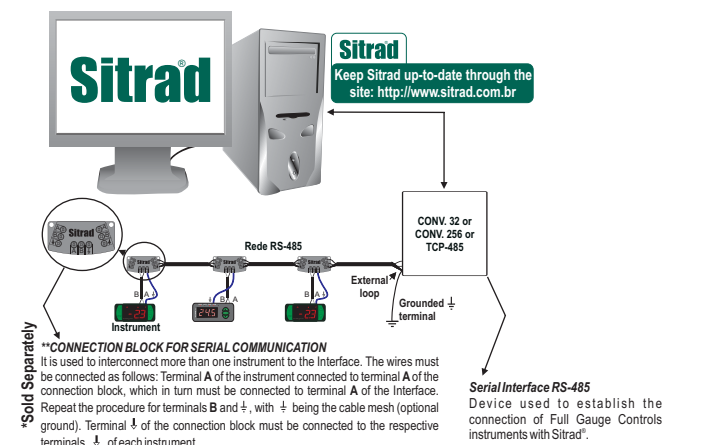
**8. INTERCONNECTING CONTROLLERS, RS-485 SERIAL INTERFACE, AND COMPUTER**

## 9. OPTIONAL ITEMS – Sold Separately

### EasyProg - version 2 or later

It is an accessory which has the main function of storing the of controller parameters. At any time you can load new controller parameters and unload them on a production line (of the same controller), for example. It is provided with three types of connections for loading or unloading the parameters:

- **Serial RS-485:** It is connected via RS-485 network to the controller (only for those controllers provided with RS-485).
- **USB:** It is connected to the computer via USB port, using the Sitrad Preset Editor.
- **Serial TTL:** The controller may be connected directly to

**EasyProg** via Serial TTL connection

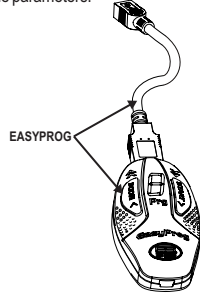

### IMPORTANT



**IN ORDER TO BE ABLE TO COMMUNICATE WITH EASYPROG THIS CONTROLLER MUST NOT COMMUNICATE WITH SITRAD.**

### E-case

Recommended for the Evolution line, it prevents water from entering the back part of the instrument. It protects the product when the installation site thereof is washed.

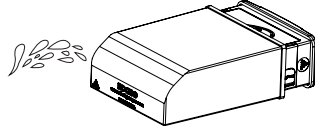

### Extension Frame

To install controllers with maximum dimensions of 76 x 34 x 77 mm (opening dimensions of 71 x 29 mm for installation in the extended frame) in several situations, because it does not require precision of the opening to embed the instrument. It allows customization through a sticker with the brand and company contact, in addition to being accompanied by two 10 A (250 V AC) switches that can trigger internal light, air curtain, on/off system or fan.

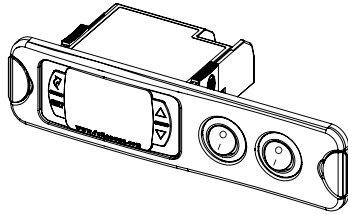

### Electrical noise suppression filter

Wiring diagram of suppressors in contactors

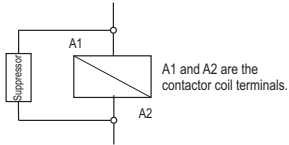

Wiring diagram of suppressors in direct drive loads

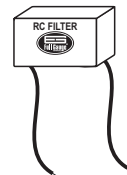
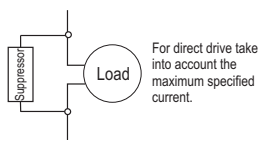

## ENVIRONMENTAL INFORMATION

### Packaging:

The materials used in the packaging of Full Gauge products are 100% recyclable. Try to perform disposal through specialized recyclers.

### Product:

The components used in Full Gauge controllers can be recycled and reused if disassembled by specialized companies.

### Disposal:

Do not incinerate or dispose the controllers that have reached the end of their service as household garbage. Observe the laws in your area regarding disposal of electronic waste. If in doubt, please contact Full Gauge Controls.

## WARRANTY - FULL GAUGE CONTROLS

Products manufactured by Full Gauge Controls, as of May 2005, have a two (02) year warranty, as of the date of the consigned sale, as stated on the invoice. They are guaranteed against manufacturing defects that make them unsuitable or inadequate for their intended use.

### EXCEPTIONS TO WARRANTY

The Warranty does not cover expenses incurred for freight and/or insurance when sending products with signs of defect or faulty functioning to an authorized provider of technical support services. The following events are not covered either: natural wear and tear of parts; external damage caused by falls or inadequate packaging of products.

### LOSS OF WARRANTY

Products will automatically lose its warranty in the following cases:

- The instructions for assembly and use found in the technical description and installation procedures in Standard IEC60364 are not obeyed;
- The product is submitted to conditions beyond the limits specified in its technical description;
- The product is violated or repaired by any person not a member of the technical team of Full Gauge Controls;
- Damage has been caused by a fall, blow and/or impact, infiltration of water, overload and/or atmospheric discharge.

### USE OF WARRANTY

To make use of the warranty, customers must send the properly packaged product to Full Gauge Controls together with the invoice or receipt for the corresponding purchase. As much information as possible in relation to the issue detected must be sent to facilitate analysis, testing and execution of the service.

These procedures and any maintenance of the product may only be provided by Full Gauge Controls Technical Support services in the company's headquarters at Rua Júlio de Castilhos, 250 - CEP 92120-030 - Canoas - Rio Grande do Sul - Brasil

Rev. 03

© Copyright 2023 • Full Gauge Controls ® • All rights reserved.