



MT-514E FASTON Ver.03

DIGITAL CONTROLLER FOR HEATING OR COOLING WITH DEFROST AND CONFIGURABLE ALARM OUTPUT

- Connector for quick coupling
- Audible Alarm
- Defrost
- Function blocking
- Control functions shutdown
- Serial Programming
- Protection level IP 65 FRONT



MT514EFASTONV03-04T-18525 -2604

Have this manual in the palm of your hand by FG Finder application.

WARNING

- BEFORE INSTALLING THE CONTROLLER, WE RECOMMEND READING THROUGH THE ENTIRE INSTRUCTION MANUAL IN ORDER TO AVOID POSSIBLE DAMAGE TO THE PRODUCT**
 - PRECAUTIONS WHEN INSTALLING THE PRODUCT:**
Before performing any procedure on this instrument, disconnect it from the mains; Ensure that the instrument has adequate ventilation and avoid installation in panels containing devices that may cause it to operate outside the specified temperature limits; Install the product away from sources that may generate electromagnetic disturbances such as: motors, contactors, relays, solenoid valves, etc;
 - SERVIÇO AUTORIZADO:**
A instalação ou manutenção do produto deve ser realizado somente por profissionais qualificados;
 - ACESSÓRIOS:**
Utilize apenas acessórios originais Full Gauge Controls. Em caso de dúvidas, entre em contato com o suporte técnico.
- POR ESTAR EM CONSTANTE EVOLUÇÃO, A FULL GAUGE CONTROLS RESERVA-SE O DIREITO DE ALTERAR AS INFORMAÇÕES CONTIDAS NO MANUAL A QUALQUER MOMENTO, SEM PRÉVIO AVISO.**

ATTENTION

FOR INSTALLATIONS WHERE A SEALING IS REQUIRED TO AVOID LIQUID CONTACT, THE CUT FOR THE CONTROLLER MUST BE OF 70,5X29mm MAXIMUM. THE SIDE LATCHES MUST BE FIXED SO IT PRESSES THE RUBBER SEALING AVOIDING INFILTRATION BETWEEN THE CUT AND THE CONTROLLER.

Image I

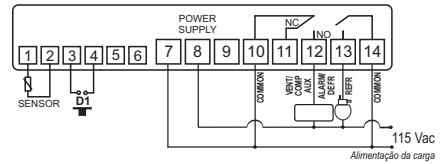

Image II

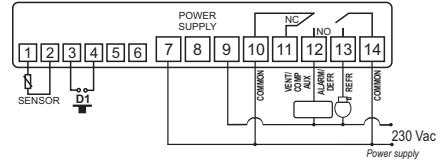

Image III

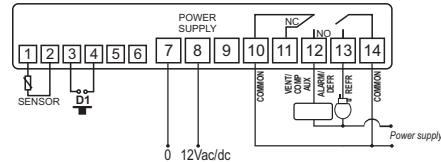
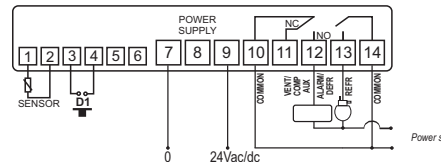
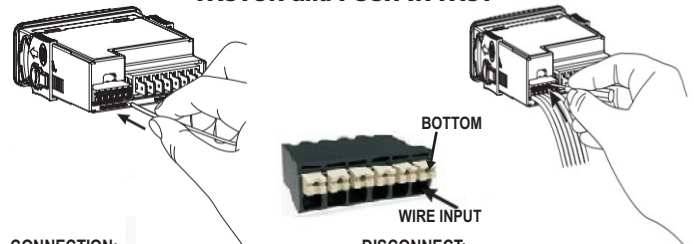

Image IV



NEW CONNECTION SYSTEM (QUICK COUPLING): FASTON and PUSH-IN FAST



CONNECTION:

- Hold the wire near its end and insert it into the desired slot.
- If necessary, press the bottom to assist the connection.

DISCONNECT:

- To disconnect the cord, press the bottom and remove it.

NOTE:

- In the Push-In connectors the maximum wire gauge that can be used is 1.5mm².
- The wires must be tinned or use Rocket Pin terminals with a maximum gauge of 0.75mm².

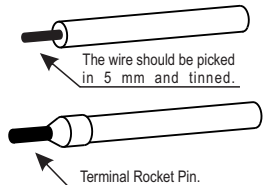

5.2. Temperature sensor connection

- Connect the sensor S1 wires to terminals "1 and 2" spring type connector. The polarity is not relevant.
- Length of the sensor cables can be increased by user himself to up to 200 meters, using a PP2x24 AWG cable.

5.3. Recommendations of IEC60364 standard

- Install overload protectors in the controller supply.
- Install transient suppressors – suppressor filter RC – in the circuit to increase the service life of the controller relay. See connection instructions of the filter on the previous page.
- The sensor cables may be together, but not in the same conduit where the power supply of the controller and/or of the loads passes through.

6. FIXING PROCEDURE

- Cutout the panel plate (Image V - item 13) where the controller will be fixed, with dimensions X = 71±0,5 mm and Y = 29±0,5 mm;
- Remove the side locks (Image VI - item 13): To do this, squeeze the elliptical central part (with the Logo Full Gauge Controls) and move the latches back;
- Pass the wires through the cutout of the plate (image VII - Item 13) and make the electrical installation as described in item 6;
- Insert the controller into the panel cutout, from the outside in;
- Replace the latches and push them until they are pressed against the panel, securing the controller to the housing (see arrow in Figure VI - item 13);
- Adjust the parameters as described in item 9.

WARNING: for installations requiring liquid-tight sealing, the cut-off for the installation of the controller should be at most 70.5x29mm. The side latches must be secured so that they press the rubber sealing to prevent infiltration between the cutout and the controller.

1. DESCRIPTION

The **MT-514E FASTON** is a temperature controller for cooling or heating applications. It has an internal audible alarm (buzzer) and an output for alarm control that can also be configured for electric defrost, hot gas defrost, fan or as a second compressor that will act in parallel with the main one. The minimum and maximum temperature record is displayed at the touch of a single key (Flatec). Another available feature is the shutdown of control functions, making it possible for the **MT-514E FASTON** to operate only as a temperature indicator. And through an intelligent function blocking system, it prevents unauthorized persons from changing the control parameters. Product is compliant with UL Inc. (United States and Canada).

2. APPLICATION

- Vaccine refrigerators
- Refrigerated counters
- Freezers rooms
- Hot counters
- Greenhouses

3. TECHNICAL SPECIFICATIONS

Power supply	MT-514 E Faston: 115 or 230 Vac ±10%(50/60 Hz) MT-514 EL Faston: 12 or 24 Vac/dc +10%
Control temperature	-50 to 105°C (-58 to 221°F)*
Operating temperature	0 to 50 °C / 32 to 122°F
Load current (outputs)	OUT1: 16(12)A 250Vac 2HP OUT2: 10A / 240Vac 1/4HP
Operating humidity	10 to 90%RH (without condensation)
Dimensions (WxHxD)	76 x 34 x 84 mm
Dimensions of the clipping for fixing of the instrument	71 ± 0,5 x 29 ± 0,5 mm (see item 5)

(*) This instrument measures and controls temperatures of up to 200°C/392°F, using the silicone sensor cable SB59 (sold separately).
Note: The sensor cable length can be increased by the user up to 200 meters using PP2x24 AWG cable.

4. INDICATIONS AND KEYS

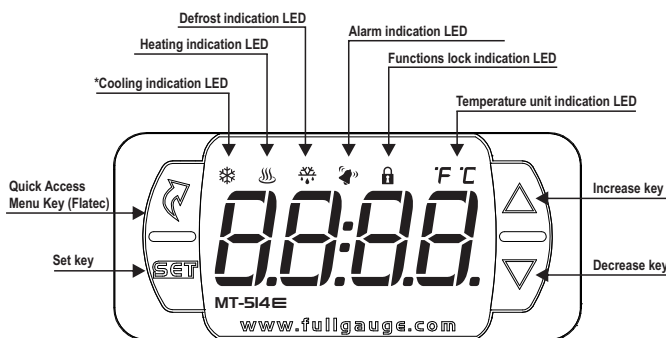

* Blinking led (when $\square F 26$) = 7): Indicates that OUT1 has been activated and the compressor delay is occurring before trigger OUT2

5. WIRING DIAGRAM

5.1. Identifications (see Images I to IV)

- Image I: MT-512E 2HP Faston, supplied at 115 Vac.
- Image II: MT-512E 2HP Faston, supplied at 230 Vac.
- Image III: MT-512EL 2HP Faston, supplied at 12 Vac/dc.
- Image IV: MT-512EL 2HP Faston, supplied at 24 Vac/dc.

Vinyl protector - Image IX (item 13)

Protects the controller should when installed in a place with splashing water, such as in refrigerated counters. This adhesive vinyl accompanies the instrument, on the packaging.

▲ IMPORTANT: Apply only after completing electrical connections.

- Retract the lateral locks (Image VI - item 13);
- Remove the protective film from the adhesive side of the vinyl;
- Apply the vinyl over the whole top, folding the flaps, as indicated by the arrows - Image IX (item 13);
- Reinstall the latches.

Note: The vinyl is transparent, allowing to visualize the electric scheme of the instrument.

7. OPERATIONS

7.1. Quick Access Menu Map

To access or browse in the quick access menu, use the **▲** key (quick touch) while the temperature is being displayed by the controller. Each touch displays the next function of the list; for confirming, use the **▼** key (quick touch). For further details, refer to chapter 6.3.

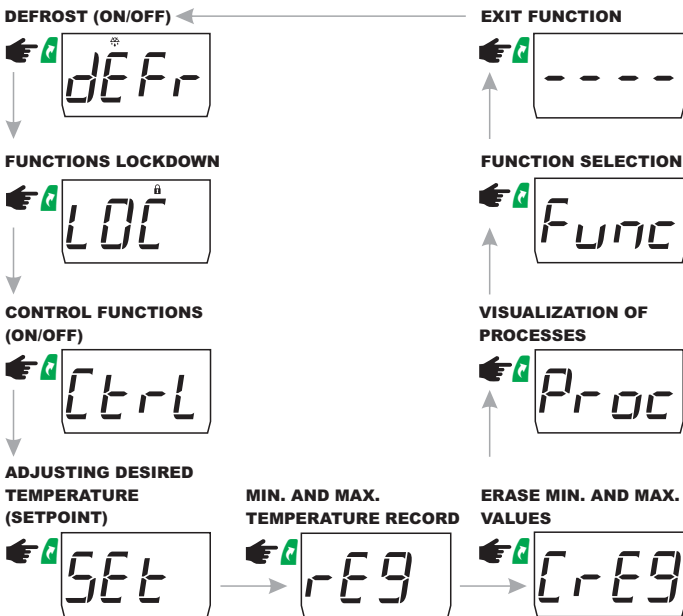

7.2. Quick access keys map

When controller is on temperature display mode, the following keys can be used as a shortcut for the following functions:

	Quick touch: enters quick access menu.
	Pressed for 5 seconds: turn on/turn off the control functions.
	Hold down for 2 seconds: setpoint adjustment.
	Quick touch: maximum and minimum temperature display.
	Hold down for 4 seconds: carries out manual defrost.
	Quick touch: display of current process and sensor temperature when [F41] = 1 or 2.
	Hold down for 2 seconds: inhibit audible alarm (buzzer).
	Hold down simultaneously: enters function selection.

7.3. Basic operations

7.3.1. Adjusting desired temperature (setpoint)

If configured not to use recipes (F03=[n0]):

- Hold down the **▼** key for 2 seconds until the message [SEt] is displayed;
- Then the message [SP] will be displayed and the setpoint may be adjusted;
- Use the **▼** or **▲** keys for changing the value, then press **▼** to confirm.

If configured to use presets (F03=[yE5]):

Each preset may be set up to use different values for the Setpoint, Control differential (hysteresis) and Cooling time (interval between defrosts).

To select the preset:

- Hold down the **▼** key for 2 seconds until the message [SEt] is displayed;
- Then the currently selected preset will appear [rE1] or [rE2].
- Use the **▼** or **▲** keys to select which of the 2 presets will be used.
- To confirm the selection, press **▼**.

Note: The values of functions Setpoint, Control differential (hysteresis) and Cooling time (interval between defrosts) for each preset are set up in the parameters menu.

7.3.2. Manual Defrost

Manual defrost can be carried out through the easy menu, decrement key or digital input.

Defrost using the easy menu: Press the key **▲** (short touch) until the message [DEFr] (flashing led) appears, then press the **▼** key (short touch) to select. Then the following message will be displayed [DEFr] [On] (led access). To switch off the defrost manually, press the button **▲** (short touch) until the message [DEFr] (flashing led) appears. Press the **▼** key (short press) to select. Then the message [DEFr] [OFF] (led off).

Defrost using the **▲ key (increments):** To activate / deactivate the defrost manually, just press the **▲** key for 4 seconds.

Defrost via digital input: If function [F35] - Digital input operation mode is set to [] - Digital input: Manual defrost, just touch the button (not supplied) connected to the digital input.



7.3.3. Functions lockdown

The use of the functions lockdown brings greater security to the operation of the instrument. When it is active, the setpoint and other parameters can be visible to the user, but are protected against undue changes ([F42]=2) or you can block changes of control functions and leave the adjustment of the setpoint enabled ([F42]=1).

Using the key **▲** (short touch), access the function [LOC] in the easy menu, confirm by pressing **▼** (short touch), then the message [n0] will be displayed. After that keep the key **▼** pressed for the time configured for the functions lockdown [F43], until [LOC] is displayed. The message [On] will be displayed indicating the lockdown function is activated upon releasing the key.



To unlock, turn the controller off and then turn it on again with the key **▼** pressed. Keep the key pressed until [LOC] is displayed. Keep the key pressed for ten seconds and the message [OFF] will be shown on the display indicating the deactivation of the lockdown function when the key is released.

7.3.4. Shutdown of Control Functions

Turning off control functions allows the controller to operate only as a temperature indicator, keeping the control outputs and alarms off. The use of this feature is enabled or not by the Shutdown of Control Functions feature [F44]. When enabled, the control and alarm functions are turned off ([Ctrl] [OFF]) or turned on ([Ctrl] [On]) through the menu provided in the option [Ctrl]. When the control functions are switched off, the message [OFF] will be displayed alternately with the temperature and other messages. Control functions can be switched off / on by pressing the key **▲** for 5 seconds or by setting the [F35] function - Digital input operation mode to [] - Digital input: To switch off the manual control, just touch the button (not supplied) connected to the digital input to activate or deactivate this functionality.

Note: When restarting the control functions, the times defined in the functions are counted, and these delay the powering up of the instrument and the alarm inhibition time when switching on the controller..



7.3.5. Visualization of Processes

To view the process and the time elapsed, press **▼** (quick touch) or by the **▲** (Flatec) key pressing it until the message [Proc] appears. This way, the controller will display the current process status, and the following messages may appear on the display:

- [DEL] - Initial delay (delay in the instrument start-up)
- [DEFr] - Cooling
- [HEt] - Heating
- [DEFr] - Defrost
- [DrA] - Drainage
- [---] - Control functions off

Note: If the function [F41] - Display indication has been set to [EOL] or [USE], the message of the process in progress will be displayed, the time elapsed from this process and then the message [EOP] followed by the display of the measured temperature by the sensor, for a few seconds on the display.

7.3.6. Minimum and Maximum Temperature Record

Pressing down the **▲** key or also via the quick access menu (see chapter 6), will cause the message [REg] to be displayed, then the minimum and maximum temperatures recorded.

For erasing the current minimum and maximum values, hold down the **▲** key (quick touch) until the message [CrEg] is displayed, then the message [EOD] will appear; enter the value [123], then confirm with the **▼** key. If the code is correctly entered, the message [SEt] will be displayed. [SEt]. This procedure keeps unauthorized users from erasing the minimum and maximum temperature records.

Note 1: The minimum and maximum temperature records shall only be performed after the elapsing of the alarm inhibition time when energizing the controller and after the delay in the instrument energizing [F32]+[F19].

Note 2: The minimum and maximum temperature records shall only be performed after the compressor reaches the active preset setpoint; before that, the [---] messages will be displayed for the records of minimum and [---] for the records of maximum temperature.

7.3.7. Unit Selection

To select the temperature unit in which the instrument will operate enter the function [F01] using the access code [231] then press the **▼** key. Then, select the unit desired [oC] or [oF] using the **▼** or **▲** keys; to confirm press **▼**. Every time the unit is changed, the functions settings return to the default value, thus, they must be set up again.

7.3.8. Buzzer inhibition

When activated, the buzzer can be inhibited by pressing the **▼** key for two seconds. The Buzzer will remain inhibited until a new alarm event takes place.

7.4. Advanced operations

The functions menu can be accessed through the quick access menu (according to chapter 6), option [Func] or by pressing simultaneously **▼** and **▲** during the temperature display. To allow change of parameters, enter [F01] by pressing **▼** (quick touch) and using the **▼** or **▲** keys enter code 123 (one hundred and twenty-three), and then confirm with **▼**. For changing the other functions, browse the menu through the **▼** or **▲** keys and proceed the same way in order to adjust them. To exit the menu and return to the normal operation, press **▼** (long touch) until [---] is displayed.

OBS: If the functions lockdown is enabled, when pressing the **▼** or **▲** keys, the controller will display the message [LOC] and will not allow parameter adjustment.

7.5. Parameter table

Fun	Description	CELSIUS				FAHRENHEIT			
		Min	Max	Unit	Default	Min	Max	Unit	Default
F01	Access code: 123 (one hundred and twenty three)	-	-	-	-	-	-	-	-
F02	Sensor indication offset	-20,0	20,0	°C	0,0	-36	36	°F	0
F03	Using Presets	no	yes	-	no	no	yes	-	no
F04	Output operation mode (OUT1)	0-cool.	1-heat.	-	0-cool.	0-cool.	1-heat.	-	0-cool.
F05	Output setpoint (rc1)	-50,0	200,0	°C	4,0	-58	392	°F	39
F06	Output control differential (Hysteresis) (rc1)	0,1	20,0	°C	1,0	1	36	°F	1
F07	Cooling time (interval between defrosts) (rc1)	1	9999	min.	240	1	9999	min.	240
F08	Defrost duration time (rc1)	0(no)	999	min.	30	0(no)	999	min.	30
F09	Output setpoint (rc2)	-50,0	200,0	°C	0,0	-58	392	°F	32
F10	Output control differential (Hysteresis) (rc2)	0,1	20	°C	1	1	36	°F	1
F11	Cooling time (interval between defrosts) (rc2)	1	9999	min.	240	1	9999	min.	240
F12	Defrost duration time (rc2)	0(no)	999	min.	30	0(no)	999	min.	30
F13	Minimum setpoint allowed for end user	-50,0	200,0	°C	-50,0	-58	392	°F	-58
F14	Maximum setpoint allowed for end user	-50,0	200,0	°C	75,0	-58	392	°F	167
F15	Minimum OUT1 output time on	0(no)	999	sec.	20	0(no)	999	sec.	20
F16	Minimum OUT1 output time OFF	0(no)	999	sec.	20	0(no)	999	sec.	20
F17	Initial state when powering up the instrument	0-cool.	1-defr.	-	0-cool.	0-cool.	1-defr.	-	0-cool.
F18	Temperature indication locked during defrost	no	yes	-	no	no	yes	-	no
F19	Delay in powering up the instrument (delay)	0(no)	240	min.	0(no)	0(no)	240	min.	0(no)
F20	Compressor status with sensor disconnected	0	2	-	0	0	2	-	0
F21	Compressor on time with sensor disconnected	1	999	min.	15	1	999	min.	15
F22	Compressor off time with sensor disconnected	1	999	min.	15	1	999	min.	15
F23	Maximum compressor on without reaching setpoint	0(no)	9999	min.	0(no)	0(no)	9999	min.	0(no)
F24	Low temperature alarm	-50(no)	200,0	°C	-50(no)	-58	392	°F	-58
F25	High temperature alarm	-50(no)	200,0	°C	200(no)	-58	392	°F	392
F26	Output OUT2 operation mode	1	7	-	1	1	7	-	1
F27	Fan Operation Mode during cooling	0	2	-	0	0	2	-	0
F28	Fan On Time	1	99	min.	2	1	99	min.	2
F29	Fan Off Time	1	99	min.	2	1	99	min.	2
F30	Fan delay	0(no)	999	min.	2	0(no)	999	min.	2
F31	Time delay between compressors activations	0(no)	99	seg.	15	0(no)	99	sec.	15
F32	Alarm inhibition time when powering up the controller	0(no)	999	min.	0(no)	0(no)	999	min.	0(no)
F33	Alarm inhibition time by room temperature	0(no)	999	min.	0(no)	0(no)	999	min.	0(no)
F34	Enable Buzzer (0-Disabled / 1-Enabled)	0(off)	1(on)	-	0(off)	0(off)	1(on)	-	0(off)
F35	Digital input operation mode	0(no)	8	-	0(no)	0(no)	8	-	0(no)
F36	Output on time in OUT2 alarm status	0	999	sec.	1	0	999	sec.	1
F37	Output off time in OUT2 alarm status	0	999	sec.	1	0	999	sec.	1
F38	Door open time to trigger alarm	0(no)	999	min.	0(no)	0(no)	999	min.	0(no)
F39	Sensor digital filter intensity	0	1	-	0	0	1	-	0
F40	Intensity of the digital filter applied to the sensors	0(no)	20	sec.	0(no)	0(no)	20	sec.	0(no)
F41	Display indication	0	2	-	0	0	2	-	0
F42	Functions lockdown	0	2	-	0	0	2	-	0
F43	Time for functions lockdown	15	60	sec.	15	15	60	sec.	15
F44	Control functions shutdown	0(no)	2	-	0(no)	0(no)	2	-	0(no)

7.5.1. Description of parameters

F01 - Access code 123 (one hundred and twenty-three):

This is required when intending to change the configuration parameters. Entering of this code is not required if the intention is just visualizing the parameters adjusted.

It allows entering of the expected access codes:

- Allows access for changing the table parameters.

- Allows configuring of the unit of measurement or .

- To select the unit in which the instrument will operate enter the function using the access code then press the key. Then, select the unit desired or using the or keys; to confirm press .

Note: Every time the unit is changed, the parameters should be reset, since they assume the 'standard' values of the parameter's table.

F02 - Sensor indication offset:

Allows compensation for any temperature deviations from sensor replacement or change in the cable length.

F03 - Using Presets:

Allows configuration of the controller so as whether or not to use the presets:

- No: If configured this way, the instrument will not use the preset values in the control routines.

For this purpose, the setpoint will be used, adjusted via the quick access menu. The control differential to be used shall be the same as in preset , "OUT1 output control differential ()". The cooling time to be used shall be the same as in preset , "OUT1 output cooling time ()". Defrost time to be used will be the same as in preset 1, "OUT1 output defrost time ()".

The value configured in may be adjusted between "Minimum setpoint allowed to the end user" and "Maximum setpoint allowed to the end user".

In this configuration, the controller will not indicate which preset is enabled.

- Yes: Selection of presets will be made through the quick access menu, in the same way as for adjusting the setpoint. In this configuration, the controller will indicate in the display which preset is enabled, or . If configured this way, in the control routines the instrument will use the values of setpoint, control differential, cooling time and defrost time configured in the parameters table.

F04 - Output operating mode OUT1:

Selects the out1 output operating mode:

- Cooling

- Heating

F05 - Operation setpoint ():

It is the reference value for temperature control, that is, the temperature to be maintained in a controlled environment when preset () is used.

F06 - Output control differential (Hysteresis) ():

It is the difference in temperature (hysteresis) between TURNING ON and OFF the cooling (or heating) when recipe () is used.

Example: One wants to control the temperature at 4.0 °C with a differential of 1.0 °C. Therefore, the cooling is switched off at 4.0 °C and switched back on at 5.0 °C (4.0 + 1.0).

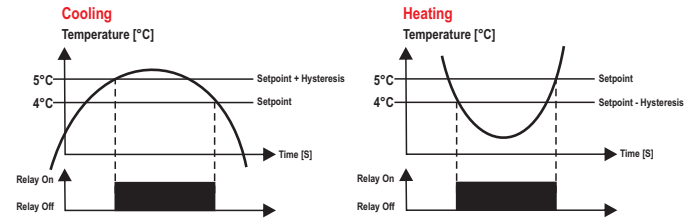

F07 - Cooling time (interval between defrosts) ():

Corresponds to the time the controller will act on cooling when preset () is used; following this period, the controller enters the natural defrost process.

F08 - Defrost duration time ():

It is the defrost duration time when preset () is used. Within this period, the relay will remain off; following this period, the controller will then return to the cooling state.

F09 - Output setpoint ():

It is the reference value for temperature control, that is, the temperature to be maintained in a controlled environment when preset () is used.

F10 - Output control differential (Hysteresis) ():

It is the difference in temperature (hysteresis) between TURNING ON and OFF the cooling (or heating) when preset () is used.

Example: One wants to control the temperature at 4.0 °C with a differential of 1.0 °C. Therefore, the cooling is switched off at 4.0 °C and switched back on at 5.0 °C (4.0 + 1.0).

F11 - Cooling time (interval between defrosts) ():

Corresponds to the time the controller will act on cooling when recipe () is used; following this period, the controller enters the natural defrost process.

F12 - Defrost duration time ():

It is the defrost duration time when preset () is used. Within this period, the relay will remain off; at the end of this period, the controller will return to the cooling state.

F13 - Minimum setpoint allowed for end user:

Avoids regulation of excessively low setpoint temperatures by mistake.

F14 - Maximum setpoint allowed for end user:

Avoids regulation of excessively high setpoint temperatures by mistake.

F15 - Minimum OUT1 output time on:

It is the minimum time the compressor will remain on, i.e. the time interval between the last start-up and the next stop.

F16 - Minimum OUT1 output time off:

It is the minimum time the compressor will remain off, i.e. the time interval between the last stop and the next start-up. It is used to relieve the discharge pressure and increase the service life of compressor.

F17 - Initial status when powering up the instrument:

It allows defrosting when controller is energized such as, for example, upon resuming of electric power (in the event of power outage).

- Cooling

- Defrost

F18 - Temperature indication locked during defrost:

If is enabled, the indication will only be released at the next cooling cycle after the temperature reaches the "locked" value again, or after 15 minutes in cooling (as a safety measure).

F19 - Delay in powering up the instrument (delay):

This function being enabled, when the instrument is energized it only works as temperature indicator remaining with the output off during the defined time. In installations with several units of equipment, configuring different values for the delay time in the start-up of each instrument, it is possible to avoid peaks of demand by activating the loads at different times.

This delay may be of the compressor or of defrost (when defrost is configured at the start).

Note: At its end, the count of minimum time of output off is started, if there is any.

F20 - Compressor status with sensor disconnected:

If the sensor is in short-circuited, off or out of the measure range, the compressor assumes the set status in this function.

- Compressor off

- Compressor on

- Cycling according to times defined in and

Note: If in the heating mode, and in error, the output will be switched off.

F21 - Compressor on time with sensor disconnected:

F22 - Compressor off time with sensor disconnected:

These determine the minimum time the compressor will remain on/off, respectively, if the sensor is off or out of the measure range.

F23 - Maximum compressor on without reaching setpoint:

This is the maximum time the compressor may remain on without reaching the setpoint during the cooling process for safety reasons. If this time is surpassed, the output is switched off and also the visual alarm and the audible alarm (buzzer) will be activated. This function can be switched off by setting it at the minimum value 0 .

Note 1: In this situation, the controller should be switched off and switched back on so as to continue with the operation.

Note 2: If the OUT2 output is set up to work differently from the alarm, this will also be switched off for safety reasons.

F24 - Low temperature alarm:

It is the temperature below that which the instrument will visually display the low temperature alarm [H L L] as well as the audible alarm (Buzzer). The differential for switching off the alarm is fixed at 0.1°C / 1°F. This alarm considers the temperature shown on the display, thus being influenced by the temperature indication that was locked during the defrost [F 1 B]. To disable this alarm, simply set this function to the minimum value until [n 0] is displayed.

F25 - High temperature alarm:

It is the temperature above that which the instrument will visually display the high temperature alarm [H H H] as well as the audible alarm (Buzzer). The differential for switching off the alarm is fixed at 0.1°C / 1°F. This alarm considers the temperature shown on the display, thus being influenced by the temperature indication that was locked during the defrost [F 1 B]. To disable this alarm, simply set this function to the maximum value until [n 0] is displayed.

Note: For safety, output OUT1 is switched off if the controller is configured for heating and a high temperature alarm [H H H] occurs, or if it is configured for cooling and a low temperature alarm [H L L] occurs, therefore, you must set the alarm limits above (if heating) or below (if cooling) the desired temperature (setpoint of output OUT1).

F26 - Output OUT2 operation mode:

Select the operating mode of the OUT2 output.

[1] - **Extra alarm-absolute range:** It considers the values defined in [F 2 4] and [F 2 5] as minimum and maximum values to trigger the alarm output.

[2] - **Extra alarm-setpoint range:** It considers the active receipt setpoint [r c 1] or [r c 2] and the absolute values defined in [F 2 4] and [F 2 5], that is, the positive value of these functions as minimum and maximum values to trigger the alarm output.

For example:

Desired temperature [S P]: -5°C

Low temperature alarm [F 2 4]: 2°C

High temperature alarm [F 2 5]: 2°C

City Limits: ([S P] - [F 2 4] and [S P] + [F 2 5]).

The low temperature alarm will go off at -7°C (-5-2) and the high temperature alarm at -3°C (-5+2).

[3] - **Electric defrost (using resistances):** Where only the OUT2 output is activated during the defrost process.

[4] - **Hot gas defrost:** Where the compressor outputs OUT1 and OUT2 are activated during the defrost process.

[5] - **Output OUT2 as NF of output OUT1:** In this option, the OUT2 output is activated when the OUT1 output is deactivated, regardless of the state (cooling / heating or defrost), except when the sensor is in error [F 2 0].

[6] - **OUT2 output as ventilation:** While the controller is cooling, the output remains in operation accordingly to the configuration selected in function [F 2 7] - Fan operation mode during cooling and remains on during the defrost duration time.

[7] - **OUT2 output as an auxiliary compressor:** The output is used to start a second compressor. Output OUT2 is activated immediately after output OUT1 is activated or according to [F 3 7] - Time delay between compressors activations.

Note 1: If the OUT2 output is configured to work different than an alarm, the absolute alarm indications are still visual (messages on the display) and audible (if the buzzer is enabled).

Note 2: If the OUT2 output is configured for defrost (electric or hot gas), after the defrost time has elapsed, a fixed time of 2 minutes is counted for drainage. During this dripping time, outputs OUT1 and OUT2 remain off.

Note 3: If output OUT2 is configured for ventilation, and if a sensor error occurs, output OUT2 will be activated and deactivated together with output OUT1, that is, if OUT1 is activated OUT2 remains activated, and will continue to work together according to the configuration selected in function [F 2 0] - Compressor status with the sensor disconnected.

Note 4: If OUT2 output is configured as ventilation and function [F 3 5] (Digital input operating mode) is configured as 1 or 2 (door open), OUT2 output will be turned off whenever the door is opened and turned back on when closing the door. If the door remains open for the time defined in [F 3 8] (Door open time to issue alarm), the OUT1 and OUT2 outputs will remain off while the door is open and will be turned back.

F27 - Fan operation mode during cooling:

Selects the operating mode of the OUT2 output when [F 2 6] = 6.

[1] - OUT2 output remains activated as long as OUT1 output (compressor) is activated. When the compressor is off by setpoint, the OUT2 output cycles according to the values configured in the functions [F 2 8] - Fan Time On and [F 2 9] - Fan Time Off;

[2] - OUT2 output remains on regardless of output OUT1;

[3] - OUT2 output remains on as long as OUT1 output is on and off when OUT1 output is turned off.

F28 - Fan On Time:

F29 - Fan Off Time:

Define fan on time [F 2 8] and fan off time [F 2 9] during the off-cycle when [F 0 4] = 0, [F 2 6] = 6 and [F 2 7] = 0

F30 - Fan Delay:

Defines the time (delay) before activating the OUT2 output (if configured as fan [F 2 6] = 6) after the start of a new refrigeration cycle.

F31 - Time delay between compressors activations:

Defines the time (delay) before activating the OUT2 output (if configured as auxiliary compressor [F 2 6] = 7). Every time the OUT1 output is activated, the time configured in this function will elapse before activating the OUT2 output.

F32 - Alarm inhibition time when powering up the controller:

This is the time during which the alarm remains off even under conditions of alarm during the instrument start-up. This time will be counted after elapsing of the time configured in [F 1 9]. This function can be switched off by setting it at the minimum value 0 [n 0].

F33 - Alarm inhibition time by room temperature:

With this configuration active, the temperature will need to remain in the alarm condition during the inhibition time set, for the alarm to be indicated. That way one can prevent alerts resulting from specific temperature variations, and after defrost.

F34 - Enable buzzer (0-Disabled/1-Enabled):

Allows enabling and disabling of the internal buzzer for alarm signaling.

F35 - Digital input operation mode:

Select the operating mode of the digital input.

[n 0] - Disabled

[1] - Digital input: Door open (active when closing contact)

[2] - Digital input: Door open (active when opening contact)

[3] - Digital input: External alarm / power failure (active when closing contact)

[4] - Digital input: External alarm / power failure (active when opening contact)

[5] - Digital input: Door open and power failure (active when closing contact)

[6] - Digital input: Door open and power failure (active when opening contact)

[7] - Digital input: Push-button type switch (button) to manually start/stop defrost

[8] - Digital input: Push-button type switch (button) to switch the control functions off or on

Examples of connection for detecting open door alarm:

This configuration may be used for the **MT-SI4E Faston** to detect whether the door has been left open for a time above the value set up in "[F 3 8] - Time with open door to trigger alarm". In this configuration, the message [H O P n] is displayed when an open door alarm is detected. To that end, the user may use the NO or NC pushbuttons (not supplied) connected to the digital input, as shown in examples below:

F35 = [1]

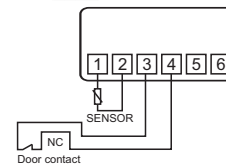

F35 = [2]

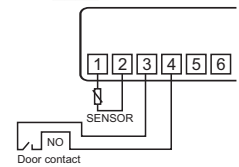

Examples of connection for power outage detection:

This configuration may be used when **MT-SI4E Faston** is being energized by a 12/24 V DC battery (common in vaccine refrigerators) and one wants to detect when a power outage occurred (115/230 V AC). In this configuration, the message [H U O L] is displayed when alarm is detected for power outage. To that end, the user may utilize a contactor or auxiliary contact (not supplied), where NC ([F 3 5] = [3]) or NO ([F 3 5] = [4]) contacts are connected to the digital input and contacts A1 and A2 (contactor coil) are connected to the power system, as shown in examples below:

F35 = [3]

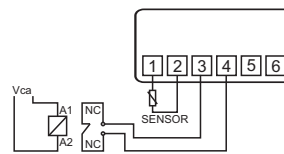

F35 = [4]

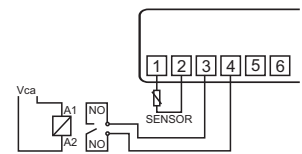

Example of connections for detecting open door and power outage:

This configuration may be used to detect power outage alarm (115/230 V AC) and also to detect that the door has been left open (either one event).

In those configurations, the messages [H U O L] and [H O P n] are displayed alternately when alarm event is detected (power outage or open door alarm).

For this purpose, the user may use the pushbuttons (not supplied) and a contactor or auxiliary contact (not supplied) connected in series or in parallel, as shown in examples below:

F35 = [5]
Parallel connection

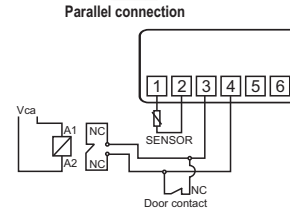

F35 = [6]
Serial connection

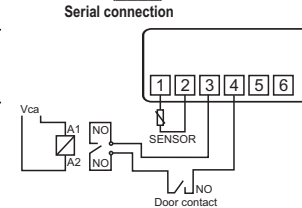

F41 - Display indication:

Defines whether the display will show the sensor temperature in real time or a static message on the display.

[0] - Displays the sensor temperature in real time

[1] - Does not display the temperature, only the message [EOL] on the display

[2] - Does not display the temperature, only the message [USE] on the display

Note: If this function is configured as [EOL] or [USE] it is possible to view the temperature measured by the sensor at any time with a short touch on the [V] key, where, firstly the message of the process in progress will be displayed as well as the elapsed time of this process and then the message [EEP] followed by the display of the temperature measured by the sensor, for a few seconds on the display.

F42 - Functions lockdown:

This allows and configures the functions lockdown.

[0] - Do not allow the functions lockdown.

[1] - Allow a partial lockdown where the control functions will be locked but the adjustment of the setpoint, manual defrost, and maximum and minimum record are allowed.

[2] - Allow the full lockdown, enabling only the manual defrost and maximum and minimum record.

F43 - Time for functions lockdown:

Allow lockdown of control functions (see item 7.3.3).

[15] - [60] Defines the time in seconds for the controller to activate.

F44 - Control functions shutdown:

Allow control functions shutdown (see item 7.3.4).

[no] - Disables the control functions shutdown.

[1] - Enables activation/deactivation of the control functions only if the functions are unlocked.

[2] - Enables activation/deactivation of the control functions even if the functions are locked.

8. SINALIZAÇÕES

[Err1]	Sensor disconnected or damaged.
[dEFr On]	Manual activation of defrost process.
[dEFr OFF]	Manual activation of end of defrost process.
[AtLo]	Low temperature alarm.
[AtHi]	High temperature alarm.
[ALrC]	Compressor reached maximum time on limit without reaching SP.
[AUoL]	Power outage alarm indication.
[ADPn]	Open door alarm indication.
[DPEn]	Open door indication.
[inib]	Buzzer inhibited.
[LOC On]	Functions lockdown.
[LOC OFF]	Unlocking of functions.
[OFF]	Control functions off.
[ECL]	Contact Full Gauge Controls.
[PPPP]	Reconfigure the values of the functions.

9. OPTIONAL ITEMS - Sold Separately

EasyProg - version 2 or higher

It is an accessory that has as its main function to store the parameters of the controllers. At any time, you can load new parameters of a controller and unload them on a production line (of the same controller), for example. It has three types of connections to load or unload the parameters:

- **Serial RS-485:** It connects via RS-485 network to the controller (only for controllers that have RS-485).

- **USB:** It can be connected to the computer via the USB port, using Sitrad's Recipe Editor.

- **Serial TTL:** The controller can be connected directly to EasyProg by the TTL Serial connection.

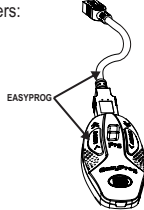

Ecase

It is recommended for the Evolution line, keeps water from entering the back part of the instrument. It also protects the product when the installation site is washed.

Note: Ecase is compatible with the use of small type Faston terminals, usually with silicone protection.

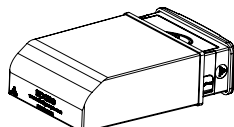

Extension Frame

The Full Gauge Controls extension frame allows the installation of Evolution / Ri line with measures 76x34x77 mm (dimensions of the clipping for fixing in the extension frame is 71x29mm) in varied situations, since it eliminates precision cut to embed the instrument. Allows customization via a sticker with the brand and the company contact, and accompany two 10A (250 Vac) switches that can trigger internal light, air curtain, on / off system or fan.

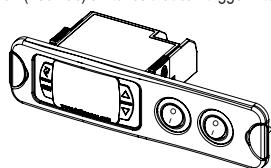

Electrical noise suppressing filter

Contact suppressor connection diagram

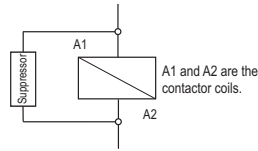
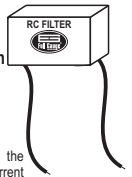
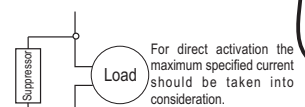

Diagram for suppressor installation for direct drive load inputs



10. ANNEXES - Reference Images

Image V

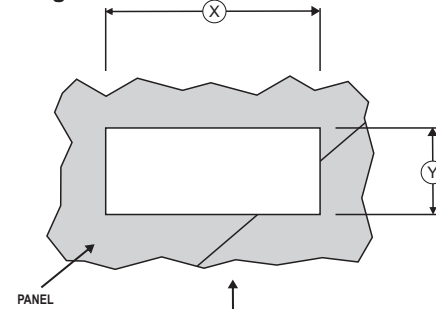

Image X

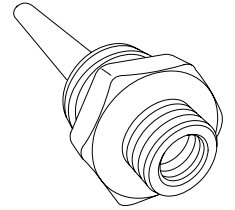

Image VI

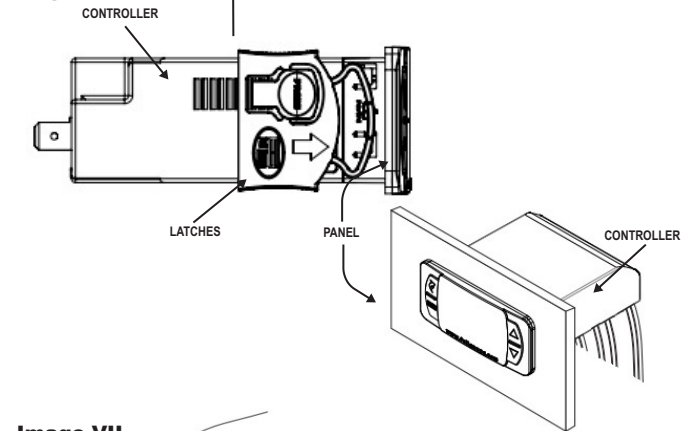

Image VII

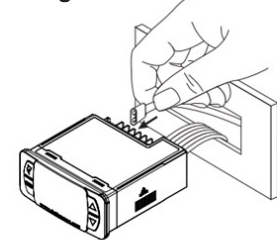
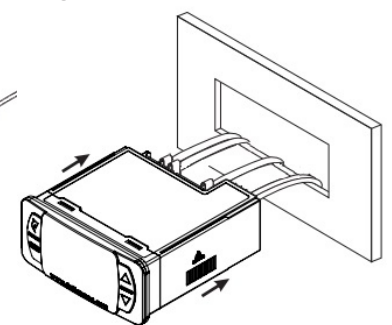

Image VII



IMPORTANT:

Faston connectors should be protected with covers, preferably silicone.

Para uma instalação correta e segura, realize todas as conexões antes de fixar o controlador.

Image IX

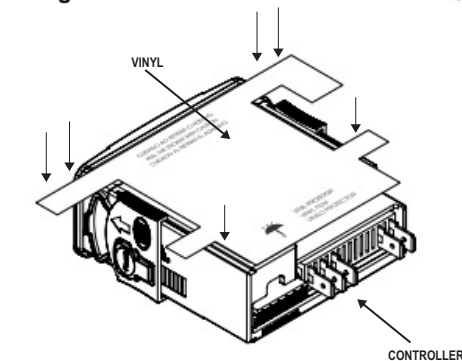



ENVIRONMENTAL INFORMATION

Packaging:

The materials used in the packaging of Full Gauge products are 100% recyclable. Try to perform disposal through specialized recyclers.

Product:

The components used in Full Gauge controllers can be recycled and reused if disassembled by specialized companies.

Disposal:

Do not incinerate or dispose the controllers that have reached the end of their service as household garbage. Observe the laws in your area regarding disposal of electronic waste. If in doubt, please contact Full Gauge Controls.

WARRANTY - FULL GAUGE CONTROLS

Products manufactured by Full Gauge Controls, as of May 2005, have a two (02) year warranty, as of the date of the consigned sale, as stated on the invoice. They are guaranteed against manufacturing defects that make them unsuitable or inadequate for their intended use.

EXCEPTIONS TO WARRANTY

The Warranty does not cover expenses incurred for freight and/or insurance when sending products with signs of defect or faulty functioning to an authorized provider of technical support services. The following events are not covered either: natural wear and tear of parts; external damage caused by falls or inadequate packaging of products.

LOSS OF WARRANTY

Products will automatically lose its warranty in the following cases:

- The instructions for assembly and use found in the technical description and installation procedures in Standard IEC60364 are not obeyed;
- The product is submitted to conditions beyond the limits specified in its technical description;
- The product is violated or repaired by any person not a member of the technical team of Full Gauge Controls;
- Damage has been caused by a fall, blow and/or impact, infiltration of water, overload and/or atmospheric discharge.

USE OF WARRANTY

To make use of the warranty, customers must send the properly packaged product to Full Gauge Controls together with the invoice or receipt for the corresponding purchase. As much information as possible in relation to the issue detected must be sent to facilitate analysis, testing and execution of the service.

These procedures and any maintenance of the product may only be provided by Full Gauge Controls Technical Support services in the company's headquarters at Rua Júlio de Castilhos, 250 - CEP 92120-030 - Canoas - Rio Grande do Sul - Brasil

Rev. 03