



# PCT-122E plus Ver.01

DIGITAL PRESSURE CONTROLLER AND INDICATOR



Have this manual in the palm of your hand through the FG Finder app.

- Suction Control
- Discharge Control
- Function Lock
- Switch off Control Functions
- Modbus Protocol
- Programming in Series
- Monitoring System
- Degree of Protection IP 65 FRONT
- Quick Coupling Connection

PCT-122PLUSV01-04T-19707 -2604

## 1. DESCRIPTION

The PCT-122E plus is a dedicated pressure switch for condensing units with features that contribute to the energy efficiency of the refrigeration system. It has two analog outputs that allow precise control of the suction and discharge processes, allowing the activation of frequency inverters, electronic fans, control module for compressor capacity variable solenoid (varistep). It also has three relay outputs for ON-OFF compressor or fan control.

It has two inputs for pressure sensors and temperature sensors, allowing monitoring of low and high pressures, in addition to superheating and subcooling measurements.

Using its integrated clock, it automatically activates the economical setpoint and night mode. The digital inputs enable remote commands for various purposes, such as: turning off the control, alarms, economical mode, night mode, among others. The PCT-122E plus allows you to configure the RS-485 communication port for the MODBUS-RTU protocol. For more information about the implemented commands and the registration table, contact Full Gauge Controls.

## 2. SAFETY RECOMMENDATIONS

- Make sure you know the correct way to install the controller;
- Make sure that the power supply is turned off and that it is not going to turn on during the installation of the controller;
- Read this manual before installing and using the controller;
- Use appropriate Personal Protective Equipment (PPE);
- Where it will be used in areas subject to splashing water, such as refrigerated counters, install the protective film that comes with the controller;
- The installation procedures must be carried out by a competent engineer, respecting current regulations.

## 3. APPLICATIONS

- Condenser units, Suction/discharge control in refrigeration systems, Superheating and subcooling monitoring.

## 4. TECHNICAL SPECIFICATIONS

Power Source	24Vdc ± 10%
Average consumption	450 mA
Pressure control range	-14,5 a 3191 PSI / -1 a 220,0 BAR (operating range of the configurable sensor)
Pressure sensor input	(*) P1 and P2: 4 - 20mA
Pressure resolution	0,1 PSI / 0,1 BAR
Temperature sensor / Digital Input	(*) T1, T2, T3 and T4: Temperature Sensor (SB19, SB41 and SB70) These inputs can be configured individually as digital inputs
Temperature control range	-50 to 105°C / -58 to 221°F
Temperature resolution	0,1°C / 0,1°F
Operating temperature	-20 to 60°C / -4 to 140°F
Working humidity	10 to 90% RH (without condensation)
Clock (RTC)	Energy backup: CR1220 battery Time keeping of up to 10 years Accuracy: ±6 minutes/year
Analog outputs	AN1 and AN2: 10Vcc (± 1%)10mA máx.
Capacity of outputs	240 Vac, 1/8 HP 120 Vac, 1/10 HP 120-240Vac, 5A Resistive 120-240Vac 5W General Use
Degree of protection	IP 65 (front)
Maximum dimensions	76 x 34 x 94mm / 2,99" x 1,33" x 3,70" (WxHxD)
Bay size	X = 71±0,5mm(2,79±0,02") Y= 29±0,5(1,14±0,02") (see Image 5)

(\*) Sensors sold separately

## 5. DISPLAY AND KEYS

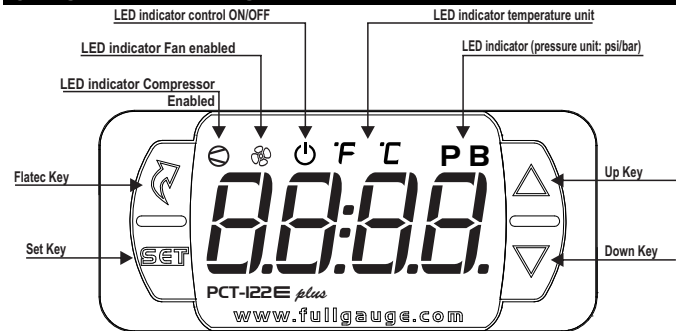

## 6. INSTALLATION - PANEL AND ELECTRICAL CONNECTION

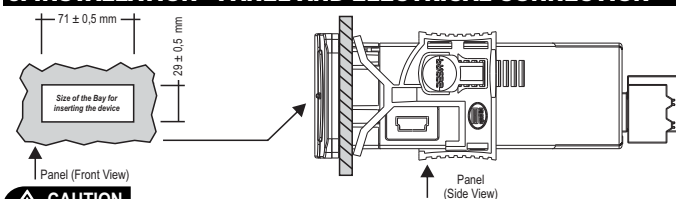

**CAUTION**  
WHERE THE INSTALLATION LOCATION NEEDS TO BE SEALED AGAINST LIQUIDS, THE OPENING IN WHICH THE CONTROLLER IS TO BE INSTALLED MUST BE NO MORE THAN 70.5x29mm. THE SIDE CLASPS MUST BE SECURED IN SUCH A WAY AS TO CREATE A TIGHT RUBBER SEAL THAT PREVENTS ANY LIQUIDS ENTERING THE OPENING AND THE CONTROLLER.

## 7. CONNECTION DIAGRAM

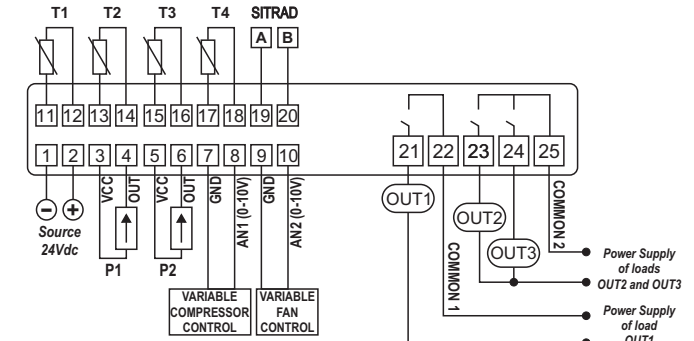

T1, T2, T3 and T4 - Configurable between Temperature sensor and digital input;  
P1 - Suction pressure transducer  
P2 - Discharge pressure transducer

AN1 - VARIABLE COMPRESSOR CONTROL  
AN2 - VARIABLE FAN CONTROL  
OUT1, OUT2 e OUT3 - Relay Outputs, Control defined according to parameterization

### 7.1. Condenser unit configuration

The configuration of parameter **F03** "Condenser unit configuration" allows you to choose how the control outputs will act depending on the type of condenser used.

SUCTION		
StSc		Start command (Control Module)*
AnSc		Analog output 0-10V
R1Sc		Relay 1 - On/Off
R2Sc		Relay 2 - On/Off
DISCHARGE		
StDs		Start command (Control Module)*
AnDs		Analog output 0-10V
R1Ds		Relay 1 - On/Off
R2Ds		Relay 2 - On/Off

\* The Control Module can be a frequency inverter or a motor module with analog input for speed control.

INDEX	SUCTION	DISCHARGE	AN1	AN2	OUT1	OUT2	OUT3
1	Variable	1x On/Off	AnSc	-	StSc	R1Ds	-
2	Variable	2x On/Off	AnSc	-	StSc	R1Ds	R2Ds
3	Variable	Variable	AnSc	AnDs	StSc	StDs	-
4	Variable	Variable + 1x On/Off	AnSc	AnDs	StSc	StDs	R1Ds
5	Variable + 1x On/Off	1x On/Off	AnSc	-	StSc	R1Sc	R1Ds
6	Variable + 1x On/Off	Variable	AnSc	AnDs	StSc	R1Sc	StDs
7	Variable + 1x On/Off	Variable + 1x On/Off	AnSc	AnDs	StSc	R1Sc	R1Ds
8	1x On/Off	1x On/Off	-	-	R1Sc	R1Ds	-
9	1x On/Off	2x On/Off	-	-	R1Sc	R1Ds	R2Ds
10	2x On/Off	1x On/Off	-	-	R1Ds	R1Sc	R2Sc
11	1x On/Off	Variable	-	AnDs	StDs	R1Sc	-
12	2x On/Off	Variable	-	AnDs	StDs	R1Sc	R2Sc

### NEW CONNECTION SYSTEM (QUICK CONNECTION): PUSH-IN WIRE CONNECTORS - QUICKLY

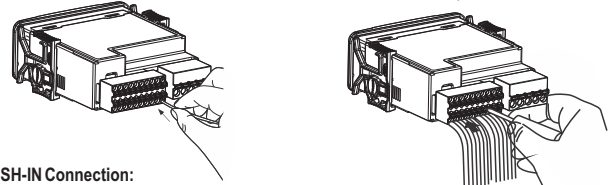

#### PUSH-IN Connection:

- Hold the wire close to its end and insert it into the required opening.

- If necessary, press the button to help make the connection.

- Ferrule type terminals can be used.

- For the signal connections, the ferrule must be at least 12mm.

In the power connectors the pin must be at least 7mm.

#### TO DISCONNECT THE PUSH-IN:

- To disconnect the wire, press the button and remove it

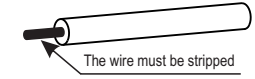

The wire must be stripped

#### NOTES 1 - Signal Connectors:

- Connections 1 to 20 must use wire of a gauge between 0.2 and 1,5mm<sup>2</sup> (26 and 16AWG).

#### NOTES 2 - Power Connectors:

- Connections 21 to 25 must use wire of a gauge between 0.2 and 2.5mm<sup>2</sup> (26 and 12AWG).



Ferrule Terminal

### 7.2. Connecting the temperature sensors

- Connect the wires of the T1 Sensor to terminals "11 and 12", the wires of the T2 sensor to terminals "13 and 14", the wires of the T3 sensor to terminals "15 and 16" and the wires of the T4 sensor to terminals "17 and 18": the polarity is indifferent.

- The length of the sensor cables can be increased by the user themselves up to 200 meters (650 ft.), using a 2x24 AWG PP cable.

### 7.3. Recommendations from NBR5410 and IEC60364 standards

a) Install surge protectors to the controller's power supply.

b) Install transient suppressors - suppressor filter (type RC) - in the circuit to increase the working life of the controller's relay.

c) The sensor cables can be together, but not in the same conduit as the power supply for the controller or the loads.



### 9.3.8 View measurements

The temporary display mode can be activated through the access menu using option **[PERS]** or by pressing the **[F]** key for 4 seconds until the message **[PERS]** is displayed.

In this visualization mode, pressing the **[F]** key or the **[A]** key (short press) it is possible to visualize the following measures (if available):

- [P-1]** - Transducer pressure P1;
- [P-2]** - Transducer pressure P2;
- [E5P1]** - P1 transducer saturation temperature;
- [E5P2]** - P2 transducer saturation temperature;
- [E-1]** - Temperature of sensor T1;
- [E-2]** - Temperature of sensor T2;
- [E-3]** - Temperature of sensor T3;
- [E-4]** - Temperature of sensor T4;
- [E1E2]** - Differential temperature between T1 and T2;
- [E3E4]** - Differential temperature between T3 and T4;
- [SH]** - Superheating temperature;
- [SC]** - Subcooling temperature;
- [dPS]** - Capacity required by suction;
- [PSC]** - Power provided by suction;
- [dDS]** - Capacity required for discharge;
- [PCD]** - Power supplied by discharge;

The message relative to the chosen measurement will alternate with the value of the measurement.

**Note:** This view will remain on the display for 15 minutes or until the **[F]** key or the **[A]** key is pressed (short press).

### 9.3.9 Function Lock

The function lock provides more security when using this device. When it is enabled the normal and economic setpoints and other parameters can be viewed, but are not able to be changed (**[F115]** = 2) or you can just lock the device against changes to the control functions but allow the normal and economic setpoints to be amendable (**[F115]** = 1). To lock the functions, access the **[LOC]** option from the access menu using the **[F]** (Flatec) key and confirm it by pressing the **[F]** key.

The message **[LO]** will be displayed if the lock is disabled. Now press and hold the **[>** key for the time configured for this function **[F116]**.

When enabled, the message **[LOC]** **[ON]** will be displayed. It can only be enabled if the function **[F115]** is set to 1 or 2.

To disable the lock, turn the controller off and on again with the **[F]** key pressed.

Keep the key pressed until the message **[LOC]** **[OFF]** indicates that it has been unlocked (10 seconds).

**Note:** Regardless of the values of **[F115]** and **[F116]** you are always able to adjust the time and hour.

### 9.3.10 Turn Off Control Functions

Turning off the control functions allows the controller to be used as a temperature / pressure indicator only, with the control outputs and alarms off. This feature can be enabled or disabled using the function, Shutdown of control functions **[F117]**. When enabled, the control and alarm functions are turned off (**[OFF]** **[OFF]**) or turned on (**[OFF]** **[ON]**) using the menu provided by the option **[OFF]**. When the control functions are turned off, the message **[OFF]** will be displayed, alternating with the temperature and other messages. It is also possible to switch off and on the control functions by pressing the **[F]** key for 5 seconds.

### 9.3.11 Record of maximum and minimum temperatures/pressures

Pressing the **[A]** key (brief press) during the temperature / pressure display, the message **[RE]** will appear and then the minimum and maximum temperatures and pressure recorded.

**Note:** If the **[A]** key is pressed during the display of the records, the values will be reset and the message **[RE]** will be displayed.

### 9.3.12 Selecting the temperature or pressure units

To select the units that the device will use, use function **[FD]** with access code **[23]** and press the **[F]** key. Next, select the required pressure unit **[PSI]** or **[BAR]** using the **[A]** **[F]** keys and confirm by pressing **[F]**. Next, select the required temperature unit **[°C]** or **[°F]** using the **[A]** **[F]** keys and confirm by pressing **[F]**.

**Note:** Whenever the units are changed, the function settings revert to the factory value and will therefore need to be reset.

## 9.4 Advanced Operations

### 9.4.1 Access to the main menu

The main menu can be accessed through the quick access menu, option **[FUNC]** or by simultaneously pressing **[A]** and **[F]** (short touch) during the pressure/temperature display.

The following options will be displayed:

- [ODE]** - Enter the access code;
- [FUNC]** - Changing the parameters;
- [LTD]** - Date and time adjustment;

### 9.4.2 Access code

To allow changing the parameters or adjust the clock, enter the **[ODE]** option by pressing **[F]** (short press) and using the **[A]** or **[F]** keys, enter the access code **[123]** (one hundred and twenty three), confirm with **[F]**.

### 9.4.3 Change the Parameters of the Controller

Within the main menu select the **[FUNC]** option and select the desired function, using the **[A]** or **[F]** keys. After selecting the function, press the **[F]** key (short touch) to view its value. Use the **[A]** or **[F]** keys to change the value and, when ready, press **[F]** to memorize the configured value and return to the function menu.

To exit the menu and return to the normal operation (temperature indication) press the **[F]** key (long press) until **[---** appears.

**Obs:** If the function lock is on, the controller will display the message **[LOC]** on the display, when the **[A]** or **[F]** keys are pressed, and will not allow any adjustment to the parameters.

## 9.5 Table of Parameters

	Fun	Description	CELSIUS (°C) / PSI				FAHRENHEIT (°F) / BAR				
			Min	Max	Unit	Standard	Min	Max	Unit	Standard	
GENERAL	<b>[ODE]</b>	Access code	0	999	-	0	0	999	-	0	
	<b>[FD1]</b>	Control delay when energizing the product	0 (Off)	9999	seconds	0 (Off)	0 (Off)	9999	seconds	0 (Off)	
	<b>[FD2]</b>	Liquid Refrigerant	1	23	-	5	1	23	-	5	
	<b>[FD3]</b>	Condensing unit configuration	1	12	-	1	1	12	-	1	
SUCTION	<b>[FD4]</b>	Type of system	1	4	-	1	1	4	-	1	
	<b>[FD5]</b>	Suction control type	0	6	-	0	0	6	-	0	
	<b>[FD6]</b>	Suction pressure setpoint	-14,5	3191	PSI	20,0	-1,0	220,0	BAR	1,3	
	<b>[FD7]</b>	Economic suction pressure setpoint	-14,5	3191	PSI	30,0	-1,0	220,0	BAR	2,0	
	<b>[FD8]</b>	Suction pressure compressor hysteresis ON/OFF (digital output)	0,1	1600	PSI	6,0	0,1	110,3	BAR	0,4	
	<b>[FD9]</b>	Variable suction pressure compressor hysteresis (analog output)	0,1	1600	PSI	10,0	0,1	110,3	BAR	0,6	
	<b>[F10]</b>	Minimum suction pressure setpoint	-14,5	3191	PSI	-14,5	-1,0	220,0	BAR	-1,0	
	<b>[F11]</b>	Maximum suction pressure setpoint	-14,5	3191	PSI	3191	-1,0	220,0	BAR	220,0	
	<b>[F12]</b>	Suction temperature setpoint	-50,0	105,0	°C	-25,0	-58,0	221,0	°F	-13,0	
	<b>[F13]</b>	Economic suction temperature setpoint	-50,0	105,0	°C	-20,0	-58,0	221,0	°F	-4,0	
	<b>[F14]</b>	Suction temperature compressor hysteresis ON/OFF (digital output)	0,1	20,0	°C	10,0	0,1	36,0	°F	18,0	
	<b>[F15]</b>	Variable suction temperature compressor hysteresis (analog output)	0,1	20,0	°C	10,0	0,1	36,0	°F	18,0	
	<b>[F16]</b>	Minimum suction temperature setpoint	-50,0	105,0	°C	-50,0	-58,0	221,0	°F	-58,0	
	<b>[F17]</b>	Maximum suction temperature setpoint	-50,0	105,0	°C	105,0	-58,0	221,0	°F	221,0	
	<b>[F18]</b>	Integral time (reserved)	0	0	-	0	0	0	-	0	
	<b>[F19]</b>	Critical pressure for shutdown - temperature control	-14,5 (Off)	3191	PSI	5,0	-1,0 (Off)	220,0	BAR	0,3	
	<b>[F20]</b>	Maximum critical pressure tolerance time - temperature control	0 (Off)	999	seconds	15	0 (Off)	999	seconds	15	
	<b>[F21]</b>	Time between compressor activation	0 (Off)	9999	seconds	5	0 (Off)	9999	seconds	5	
	<b>[F22]</b>	Time between compressor shutdowns	0 (Off)	9999	seconds	5	0 (Off)	9999	seconds	5	
	<b>[F23]</b>	Minimum compressor on time	0 (Off)	9999	seconds	60	0 (Off)	9999	seconds	60	
	<b>[F24]</b>	Minimum compressor off time	0 (Off)	9999	seconds	120	0 (Off)	9999	seconds	120	
	<b>[F25]</b>	VCC: Start time	0 (Off)	999	seconds	60	0 (Off)	999	seconds	60	
	<b>[F26]</b>	VCC: Lower validation time	0 (Off)	999	seconds	120	0 (Off)	999	seconds	120	
	<b>[F27]</b>	VCC: Upper validation time	0 (Off)	999	seconds	120	0 (Off)	999	seconds	120	
	<b>[F28]</b>	Modulation (reserved)	0	0	-	0	0	0	-	0	
	<b>[F29]</b>	Drive mode (reserved)	0	0	-	0	0	0	-	0	
	<b>[F30]</b>	Time to start Economic Setpoint	00:00	23:59	hh:mm	00:00	00:00	23:59	hh:mm	00:00	
	<b>[F31]</b>	Time to end Economic Setpoint	00:00	24:00 (Off)	hh:mm	24:00 (Off)	00:00	24:00 (Off)	hh:mm	24:00 (Off)	
	<b>[F32]</b>	Suction activation in case of sensor failure	0 (Off)	1 (Man)	-	0 (Off)	0 (Off)	1 (Man)	-	0 (Off)	
	<b>[F33]</b>	Suction output capacity in manual mode	0	100	%	50	0	100	%	50	
	<b>[F34]</b>	Suction output cycle time in manual mode	10	60	minutes	20	10	60	minutes	20	
	DISCHARGE	<b>[F35]</b>	Discharge Control Type	0	6	-	0	0	6	-	0
		<b>[F36]</b>	Discharge pressure setpoint	-14,5	3191	PSI	250	-1,0	220,0	BAR	17,2
		<b>[F37]</b>	Discharge pressure fan hysteresis ON/OFF (digital outputs)	0,1	425,0	PSI	10,0	0,1	29,3	BAR	0,6
<b>[F38]</b>		Discharge pressure variable fan hysteresis (analog output)	0,1	425,0	PSI	10,0	0,1	29,3	BAR	0,6	
<b>[F39]</b>		Minimum discharge pressure setpoint	-14,5	3191	PSI	0,0	-1,0	220,0	BAR	0,0	
<b>[F40]</b>		Maximum discharge pressure setpoint	-14,5	3191	PSI	3191,0	-1,0	220,0	BAR	220,0	
<b>[F41]</b>	Discharge temperature setpoint	-50,0	105,0	°C	60,0	-58,0	221,0	°F	140,0		

	Fun	Description	CELSIUS (°C) / PSI				FAHRENHEIT (°F) / BAR				
			Min	Max	Unit	Standard	Min	Max	Unit	Standard	
DISCHARGE	F42	Discharge temperature fan hysteresis ON/OFF (digital outputs)	0,1	20,0	°C	10,0	0,1	36,0	°F	18,0	
	F43	Discharge temperature variable fan hysteresis (analog output)	0,1	20,0	°C	10,0	0,1	36,0	°F	18,0	
	F44	Minimum discharge temperature setpoint	-50,0	105,0	°C	-50,0	-58,0	221,0	°F	-58,0	
	F45	Maximum discharge temperature setpoint	-50,0	105,0	°C	105,0	-58,0	221,0	°F	221,0	
	F46	Integral time (reserved)	0	0	-	0	0	0	-	0	
	F47	Minimum time between activations	0 (Off)	9999	seconds	5	0 (Off)	9999	seconds	5	
	F48	Minimum time between shutdowns	0 (Off)	9999	seconds	5	0 (Off)	9999	seconds	5	
	F49	Minimum fan on time	0 (Off)	9999	seconds	30	0 (Off)	9999	seconds	30	
	F50	Minimum fan off time	0 (Off)	9999	seconds	30	0 (Off)	9999	seconds	30	
	F51	Analog output start time	0 (Off)	999	seconds	10	0 (Off)	999	seconds	10	
	F52	Analog output lower validation time	0 (Off)	999	seconds	30	0 (Off)	999	seconds	30	
	F53	Analog output upper validation time	0 (Off)	999	seconds	15	0 (Off)	999	seconds	15	
	F54	Time to start Night Mode	00:00	23:59	hh:mm	00:00	00:00	23:59	hh:mm	00:00	
	F55	Time to end Night Mode	00:00	24:00 (Off)	hh:mm	24:00 (Off)	00:00	24:00 (Off)	hh:mm	24:00 (Off)	
	F56	Maximum fan limit Night Mode	30	100	%	80	30	100	%	80	
	F57	Discharge activation in case of sensor failure	0 (Off)	1 (Man)	-	0 (Off)	0 (Off)	1 (Man)	-	0 (Off)	
	F58	Discharge output capacity in manual mode	0	100	%	50	0	100	%	50	
	F59	Discharge output cycle time in manual mode	10	60	minutes	20	10	60	minutes	20	
ANALOG OUTPUTS	F60	Actuation range of analog output 1	0	2	-	0	0	2	-	0	
	F61	Minimum value of analog output 1	0	F62	%	10	0	F62	%	10	
	F62	Maximum value of analog output 1	F61	100	%	100	F61	100	%	100	
	F63	Analog output 1 starting value	F61	F62	%	10	F61	F62	%	10	
	F64	Actuation range of analog output 2	0	2	-	0	0	2	-	0	
	F65	Minimum value of analog output 2	0	F66	%	10	0	F66	%	10	
	F66	Maximum value of analog output 2	F65	100	%	100	F65	100	%	100	
SUPER HEATING	F67	Analog output 2 starting value	F65	F66	%	10	F66	F67	%	10	
	F68	Superheat calculation	0(Off)	8	-	0(Off)	0(Off)	8	-	0(Off)	
	F69	Low superheat alarm	0,0 (Off)	105,0	°C	5,0	0,0 (Off)	189,0(Off)	°F	9,0	
	F70	High superheat alarm	0,0	105,0 (Off)	°C	30,0	0,0 (Off)	189,0(Off)	°F	54,0	
SUB COOLING	F71	Time to validate the superheat alarm	0 (Off)	9999	seconds	300	0 (Off)	9999	seconds	300	
	F72	Subcooling calculation	0(Off)	4	-	0(Off)	0(Off)	4	-	0(Off)	
	F73	Low subcooling alarm	0,0 (Off)	105,0	°C	5,0	0,0 (Off)	189,0(Off)	°F	9,0	
	F74	High subcooling alarm	0,0	105,0 (Off)	°C	30,0	0,0 (Off)	189,0(Off)	°F	54,0	
PRESSURE ALARM	F75	Time to validate the subcooling alarm	0 (Off)	9999	seconds	300	0 (Off)	9999	seconds	300	
	F76	Low pressure alarm on P1 transducer	-14,5 (Off)	3191	PSI	-14,5 (Off)	-1,0 (Off)	220,0	BAR	-1,0 (Off)	
	F77	High pressure alarm on P1 transducer	-14,5	3191 (Off)	PSI	3191 (Off)	-1,0	220,0 (Off)	BAR	220,0 (Off)	
	F78	Low pressure alarm on P2 transducer	-14,5 (Off)	3191	PSI	-14,5 (Off)	-1,0 (Off)	220,0	BAR	-1,0 (Off)	
	F79	High pressure alarm on P2 transducer	-14,5	3191 (Off)	PSI	3191 (Off)	-1,0	220,0 (Off)	BAR	220,0 (Off)	
	F80	Pressure alarm hysteresis	0,1	245,0	PSI	1,0	0,1	16,9	BAR	0,1	
	F81	Pressure alarm validation time	0(Off)	9999	seconds	5	0(Off)	9999	seconds	5	
	F82	Inhibition time when pressure alarms are energized	0(Off)	9999	seconds	30	0(Off)	9999	seconds	30	
	F83	Low temperature alarm on T1 sensor	-50,0 (Off)	105,0	°C	-50,0 (Off)	-58,0 (Off)	221,0	°F	-58,0 (Off)	
	F84	High temperature alarm on T1 sensor	-50,0	105,0 (Off)	°C	105,0 (Off)	-58,0	221,0 (Off)	°F	221,0 (Off)	
TEMPERATURE ALARMS	F85	Low temperature alarm on T2 sensor	-50,0 (Off)	105,0	°C	-50,0 (Off)	-58,0 (Off)	221,0	°F	-58,0 (Off)	
	F86	High temperature alarm on T2 sensor	-50,0	105,0 (Off)	°C	105,0 (Off)	-58,0	221,0 (Off)	°F	221,0 (Off)	
	F87	Low temperature alarm on T3 sensor	-50,0 (Off)	105,0	°C	-50,0 (Off)	-58,0 (Off)	221,0	°F	-58,0 (Off)	
	F88	High temperature alarm on T3 sensor	-50,0	105,0 (Off)	°C	105,0 (Off)	-58,0	221,0 (Off)	°F	221,0 (Off)	
	F89	Low temperature alarm on T4 sensor	-50,0 (Off)	105,0	°C	-50,0 (Off)	-58,0 (Off)	221,0	°F	-58,0 (Off)	
	F90	High temperature alarm on T4 sensor	-50,0	105,0 (Off)	°C	105,0 (Off)	-58,0	221,0 (Off)	°F	221,0 (Off)	
	F91	Low saturation temperature alarm (P1 pressure transducer)	-50,0 (Off)	105,0	°C	-50,0 (Off)	-58,0 (Off)	221,0	°F	-58,0 (Off)	
	F92	High saturation temperature alarm (P1 pressure transducer)	-50,0	105,0 (Off)	°C	105,0 (Off)	-58,0	221,0 (Off)	°F	221,0 (Off)	
	F93	Temperature alarm hysteresis	0,1	50,0	°C	1,0	0,1	90,0	°F	1,8	
	F94	Time to validate the temperature alarms	0 (Off)	9999	seconds	5	0 (Off)	9999	seconds	5	
	F95	Inhibition time when temperature alarms are energized	0 (Off)	9999	seconds	30	0 (Off)	9999	seconds	30	
	REARME AUTOM.	F96	Number of automatic reset attempts	0 (Man)	11 (Aut)	-	3	0 (Man)	11 (Aut)	-	3
		F97	Interval between automatic reset attempts	1	60	minutes	15	1	60	minutes	15
		F98	Automatic reset period	1	24	hours	1	1	24	hours	1
	DIGITAL INPUTS	F99	Operating mode of the digital input 1	0	37	-	0	0	37	-	0
F100		Operating mode of the digital input 2	0	37	-	0	0	37	-	0	
F101		Operating mode of the digital input 3	0	37	-	0	0	37	-	0	
F102		Operating mode of the digital input 4	0	37	-	0	0	37	-	0	
SENSORS	F103	Displacement of the temperature indication of the T1 sensor (Offset)	-20,0	20,0	°C	0,0	-36,0	36,0	°F	0,0	
	F104	Displacement of the temperature indication of the T2 sensor (Offset)	-20,0	20,0	°C	0,0	-36,0	36,0	°F	0,0	
	F105	Displacement of the temperature indication of the T3 sensor (Offset)	-20,0	20,0	°C	0,0	-36,0	36,0	°F	0,0	
	F106	Displacement of the temperature indication of the T4 sensor (Offset)	-20,0	20,0	°C	0,0	-36,0	36,0	°F	0,0	
	F107	Lower pressure limit of the P1 transducer (Pressure at 4mA)	-14,5	3191	PSI	0,0	-1,0	220,0	BAR	0,0	
	F108	Upper pressure limit of the P1 transducer (Pressure at 20mA)	-14,5	3191	PSI	232,0	-1,0	220,0	BAR	16,0	
	F109	P1 transducer pressure indication displacement (Offset)	-50,1 (Off)	50,0	PSI	0,0	-3,4 (Off)	3,4	BAR	0,0	
	F110	Lower pressure limit of the P2 transducer (Pressure at 4mA)	-14,5	3191	PSI	0,0	-1,0	220,0	BAR	0,0	
	F111	Upper pressure limit of the P2 transducer (Pressure at 20mA)	-14,5	3191	PSI	635,0	-1,0	220,0	BAR	43,7	
	F112	P2 transducer pressure indication displacement (Offset)	-50,1 (Off)	50,0	PSI	0,0	-3,4 (Off)	3,4	BAR	0,0	
INTERFACE	F113	Enable buzzer	0 (Off)	1(On)	-	0 (Off)	0 (Off)	1(On)	-	0 (Off)	
	F114	Preferred Indicator	1	14	-	1	1	14	-	1	
	F115	Function Lock Mode	0	2	-	0	0	2	-	0	
	F116	Function Lock Period	15	60	seconds	15	15	60	seconds	15	
	F117	Shutdown of control functions	0 (Off)	2	-	0 (Off)	0 (Off)	2	-	0 (Off)	
	F118	Address of the instrument on the RS-485 network	1	247	-	1	1	247	-	1	

## 9.5.1 Description of the parameters

### F01 - Control delay when energizing the product:

When the instrument is turned on, it can remain disabled for a while, delaying the start of the process. During this time it only works as a pressure/temperature indicator. It helps to avoid high demands for power, when power returns after a power cut, where several pieces of equipment are all on the same connection. Therefore, you can set different times for each device.

### F02 - Liquid Refrigerant:

Allows you to choose which refrigerant will be used in the superheating calculation:

<input type="checkbox"/> 1 - R22	<input type="checkbox"/> 13 - R441A
<input type="checkbox"/> 2 - R32	<input type="checkbox"/> 14 - R448A
<input type="checkbox"/> 3 - R134A	<input type="checkbox"/> 15 - R449A
<input type="checkbox"/> 4 - R290	<input type="checkbox"/> 16 - R450A
<input type="checkbox"/> 5 - R404A	<input type="checkbox"/> 17 - R452A
<input type="checkbox"/> 6 - R407A	<input type="checkbox"/> 18 - R507A
<input type="checkbox"/> 7 - R407C	<input type="checkbox"/> 19 - R513A
<input type="checkbox"/> 8 - R407F	<input type="checkbox"/> 20 - R600A
<input type="checkbox"/> 9 - R410A	<input type="checkbox"/> 21 - R744
<input type="checkbox"/> 10 - R422A	<input type="checkbox"/> 22 - R1234YF
<input type="checkbox"/> 11 - R422D	<input type="checkbox"/> 23 - R1234ZE (E)
<input type="checkbox"/> 12 - R427A	

### F03 - Condensing unit configuration:

It allows you to choose how the control outputs will act depending on the type of capacitor used:

	Suction	Discharge
<input type="checkbox"/> 1	Variable	1x On/Off
<input type="checkbox"/> 2	Variable	2x On/Off
<input type="checkbox"/> 3	Variable	Variable
<input type="checkbox"/> 4	Variable	Variable+ 1xOn/Off
<input type="checkbox"/> 5	Variable+ 1xOn/Off	1x On/Off
<input type="checkbox"/> 6	Variable+ 1xOn/Off	Variable
<input type="checkbox"/> 7	Variable+ 1xOn/Off	Variable+ 1xOn/Off
<input type="checkbox"/> 8	1x On/Off	1x On/Off
<input type="checkbox"/> 9	1x On/Off	2x On/Off
<input type="checkbox"/> 10	2x On/Off	1x On/Off
<input type="checkbox"/> 11	1x On/Off	Variable
<input type="checkbox"/> 12	2x On/Off	Variable

 **Note:** For more details see item 7.1 Condensing Unit Configuration.

### F04 - Type of system:

Allows you to choose the dynamic characteristics of the system in which the controller is installed. .

- 1 - Stable system  
 2 - Oscillatory system  
 3 - Turbulent system  
 4 - Unstable system

 **Note:** The options in this parameter apply to suction control; the oscillatory system option is used to control discharge.

### F05 - Suction control type:

- FFF - Off  
 1 - Pressure (P1 pressure transducer)  
 2 - Saturation temperature (P1 pressure transducer)  
 3 - T1 temperature sensor  
 4 - T2 temperature sensor  
 5 - T3 temperature sensor  
 6 - T4 temperature sensor

### F06 - Suction pressure setpoint:

It is the control pressure of the normal operating mode, that is, it is the pressure that you want to maintain in the suction.

### F07 - Economic suction pressure setpoint:

It is the suction control pressure when the economic operating mode is active.

### F08 - Suction pressure compressor hysteresis ON/OFF (digital output):

It is the pressure difference between turning the suction control digital output on and off.

### F09 - Variable suction pressure compressor hysteresis (analog output):

It is the pressure difference between turning the suction control analog output on and off.

### F10 - Minimum suction pressure setpoint:

### F11 - Maximum suction pressure setpoint:

Limits whose purpose is to prevent excessively high or low suction pressure setpoint pressures from being set by mistake.

### F12 - Suction temperature setpoint:

It is the control temperature of the normal operating mode, that is, it is the temperature that you want to maintain in the suction.

### F13 - Economic suction temperature setpoint:

It is the suction control temperature when the economic operating mode is active.

### F14 - Suction temperature compressor hysteresis ON/OFF (digital output):

It is the temperature difference between turning the suction control digital output on and off.

### F15 - Variable suction temperature compressor hysteresis (analog output):

It is the temperature difference between turning the suction control analog output on and off.

### F16 - Minimum suction temperature setpoint:

### F17 - Maximum suction temperature setpoint:

Limits whose purpose is to prevent excessively high or low suction temperature setpoint pressures from being set by mistake.

### F18 - Integral time (Reserved):

Parameter not available in this model.

### F19 - Critical pressure for shutdown - temperature control:

Limit pressure value for compressor operation. Below this value, the compressors are turned off (it is recommended to use this function as a safety measure when control is done by temperature).

### F20 - Maximum critical pressure tolerance time – temperature control:

Time that the suction pressure must remain below the value configured in  for the compressors to turn off.

### F21 - Time between compressor activation:

Minimum time between two activations of digital suction outputs.

This time guarantees that there will be no simultaneous compressor activations, avoiding surges in the supply network and excessive fluctuations in control pressure.

### F22 - Time between compressor shutdowns:

Minimum time between two digital suction output shutdowns.

This time guarantees that simultaneous compressor shutdowns will not occur, avoiding electrical variations in the supply network and excessive fluctuations in control pressure.

### F23 - Minimum compressor on time:

It is the minimum time that the compressors will remain on, that is, the time between the last start and the next stop.

### F24 - Minimum compressor off time:

It is the minimum time that the compressors will remain off, that is, the time between the last stop and the next start.

### F25 - VCC: Start time:

This is the time that the Variable Capacity Compressor remains in the starting condition. For the VCC - Analog compressor, the analog output assumes the value configured in , but if the control calculates a demand greater than the starting value, the required value will be applied.

The VCC - Digital compressor operates without load during the starting time, that is, with a capacity equal to zero.

### F26 - VCC: Lower validation time:

This time is a validation of the need to deactivate a next compression stage and avoid unnecessary shutdowns. When the VCC compressor reaches the minimum value, where the control would immediately turn off the next compression stage (compressor On/Off), the control starts to wait this time to validate the transition and take the next action.

### F27 - VCC: Upper validation time:

This time is a validation of the need to activate a next compression stage and avoid unnecessary activations. When the VCC compressor reaches the maximum value, where the control would immediately activate the next compression stage (compressor On/Off), the control starts to wait this time to validate the transition and take the next action.

### F28 - Modulation (Reserved):

Parameter not available in this model.

### F29 - Drive mode (Reserved):

Parameter not available in this model.

### F30 - Time to start Economic Setpoint:

### F31 - Time to end Economic Setpoint:

Times to turn on/off the economic setpoint. To disable this functionality, simply set the shutdown time to the maximum value .

### F32 - Suction activation in case of sensor failure:

In case of failure in the suction control sensor, control of the open loop outputs can be maintained, applying power to the output defined in parameter .

FFF - Turns off the compressors in case of sensor failure.

RRn - Compressors in manual mode in case of sensor failure.

### F33 - Suction output capacity in Manual Mode:

Sets the suction output capacity when operating in manual mode. When using an ON-OFF compressor, the compressors cycle according to the time defined in parameter .

### F34 - Suction output cycle time in Manual Mode:

Sets the suction output cycle time in manual mode. Determines the time between one compressor activation and another.

### F35 - Discharge Control Type:

- FFF - Off  
 1 - Pressure (P2 pressure transducer)  
 2 - Saturation temperature (P2 pressure transducer)  
 3 - T1 temperature sensor  
 4 - T2 temperature sensor  
 5 - T3 temperature sensor  
 6 - T4 temperature sensor

### F36 - Discharge pressure setpoint:

It is the discharge control pressure, that is, it is the pressure that you want to maintain in the discharge.

### F37 - Discharge pressure fan hysteresis ON/OFF (digital outputs):

It is the pressure difference between turning the discharge control digital output on and off.

### F38 - Discharge pressure variable fan hysteresis (analog output):

It is the pressure difference between turning the discharge control analog output on and off.

### F39 - Minimum discharge pressure setpoint:

### F40 - Maximum discharge pressure setpoint:

Limits whose purpose is to prevent excessively high or low discharge pressure setpoint pressures from being set by mistake.

### F41 - Discharge temperature setpoint:

It is the discharge control temperature, that is, it is the temperature that you want to maintain in the discharge.

### F42 - Discharge temperature fan hysteresis ON/OFF (digital outputs):

It is the temperature difference between turning the discharge control digital output on and off.

### F43 - Discharge temperature variable fan hysteresis (analog output):

It is the temperature difference between turning on and off the discharge control analog output.

### F44 - Minimum discharge temperature setpoint:

### F45 - Maximum discharge temperature setpoint:

Limits whose purpose is to prevent excessively high or low discharge temperature setpoint pressures from being set by mistake.

**F46 - Integral time (Reserved):**

Parameter not available in this model.

**F47 - Minimum time between activations:**

Minimum time between two activations of digital outputs during discharge.

This time guarantees that there will be no simultaneous fan activations, avoiding surges in the supply network and excessive fluctuations in control variable.

**F48 - Minimum time between shutdowns:**

Minimum time between two digital output shutdowns.

This time guarantees that there will be no simultaneous fan activations, avoiding surges in the supply network and excessive fluctuations in control pressure.

**F49 - Minimum fan on time:**

It is the minimum time that the fans will remain on, that is, the time between the last start and the next stop.

**F50 - Minimum fan off time:**

It is the minimum time that the fans will remain off, that is, the time between the last stop and the next start.

**F51 - Analog output start time:**

It is the time in which the analog output remains at the starting value ( $\boxed{F57}$ ). If the control calculates a demand greater than the starting value, the required value will be applied.

**F52 - Analog output lower validation time:**

This time is a validation of the need to deactivate a next ventilation stage and avoid unnecessary shutdowns. When reaching the minimum value, where the control would immediately turn off the next fan, the control starts to wait this time to validate the transition and take the next action.

**F53 - Analog output upper validation time:**

This time is a validation of the need to activate the next ventilation stage and avoid unnecessary activations. When reaching the maximum value, where the control would immediately turn on the next fan, the control starts to wait this time to validate the transition and take the next action.

**F54 - Time to start Night Mode:****F55 - Time to end Night Mode:**

Times to turn on/off night mode. To disable this functionality, simply set the shutdown time to the maximum value  $\boxed{0FF}$ .

**F56 - Maximum fan limit Night Mode:**

Limit for controlling fan speed (EC Fan) with the aim of reducing noise during the night.

**F57 - Discharge activation in case of sensor failure:**

In case of failure in the discharge control sensor, control of the open loop outputs can be maintained by applying the output power defined in parameter  $\boxed{F58}$ .

$\boxed{0FF}$  - Turns off the fans in case of sensor failure.

$\boxed{111}$  - Fans in manual mode in case of sensor failure.

**F58 - Discharge output capacity in Manual Mode:**

Sets the discharge output capacity when operating in manual mode. When using ON-OFF fans, the fans cycle according to the time defined in parameter  $\boxed{F59}$ .

**F59 - Discharge output cycle time in manual mode:**

Sets the discharge output cycle time in manual mode. Determines the time between one fan activation and another.

**F60 - Analog output 1 actuation range:**

$\boxed{0}$  - From 0 to 10 Vdc

$\boxed{1}$  - From 0 to 5 Vdc

$\boxed{2}$  - From 1 to 5 Vdc

**F61 - Minimum value of analog output 1:****F62 - Maximum value of analog output 1:**

Minimum and maximum percentages applied to the analog suction output considering its operating range.

**F63 - Analog output 1 starting value:**

Percentage applied to the analog suction output considering its operating range during the start-up time.

**F64 - Actuating range of analog output 2:**

$\boxed{0}$  - From 0 to 10 Vdc

$\boxed{1}$  - From 0 to 5 Vdc

$\boxed{2}$  - From 1 to 5 Vdc

**F65 - Minimum value of analog output 2:****F66 - Maximum value of analog output 2:**

Minimum and maximum percentages applied to the analog discharge output considering its operating range.

**F67 - Analog output 2 starting value:**

Percentage applied to the discharge analog output considering its operating range during the starting time.

**F68 - Superheat calculation:**

$\boxed{0FF}$  - Disabled

$\boxed{1}$  - P1 and T1

$\boxed{2}$  - P1 and T2

$\boxed{3}$  - P1 and T3

$\boxed{4}$  - P1 and T4

$\boxed{5}$  - P1 and T1 (Alarm acts on the control, see item 12.2 Alarms)

$\boxed{6}$  - P1 and T2 (Alarm acts on the control, see item 12.2 Alarms)

$\boxed{7}$  - P1 and T3 (Alarm acts on the control, see item 12.2 Alarms)

$\boxed{8}$  - P1 and T4 (Alarm acts on the control, see item 12.2 Alarms)

Superheat control indicates how much steam is above saturation temperature (boiling point) at a given pressure.

A pressure transducer in the suction line and a temperature sensor are required at the evaporator outlet (useful) or at the compressor inlet (total).

Superheating = suction temperature - saturation temperature (fluid curve).

A low superheat indicates a high dosage of coolant fluid in the evaporator, which could damage the compressor due to the suction of liquid.

A high superheat indicates a low dosage of refrigerant fluid in the evaporator, which may cause high temperatures in the compressor due to the suction of superheated vapor, in addition to reducing the evaporator capacity and reducing the compressor's useful life.

**F69 - Low superheat alarm:****F70 - High superheat alarm:**

Minimum and maximum limits for superheat alarms.



**Note:** Superheat alarms only validate with a compressor running. Fixed hysteresis of 1°C/1°F.

**F71 - Time to validate the superheat alarm:**

This function is used to inhibit superheat alarms for a period of time due to a possible variation in temperature.

**F72 - Subcooling calculation:**

$\boxed{0FF}$  - Disabled

$\boxed{1}$  - P2 and T1

$\boxed{2}$  - P2 and T2

$\boxed{3}$  - P2 and T3

$\boxed{4}$  - P2 and T4

The subcooling control indicates how much colder the coolant fluid is than the condensing temperature necessary to avoid loss of performance due to the evaporation of the coolant liquid before the expansion valve.

A pressure transducer is required in the liquid line and a temperature sensor at the condenser outlet.

Subcooling = saturated liquid temperature - liquid line temperature.

Low subcooling indicates low heat exchange in the evaporator and risk of flash gas before the expansion valve.

High Subcooling may indicate high pressures in the system.

**F73 - Low subcooling alarm:****F74 - High subcooling alarm:**

Minimum and maximum limits for subcooling alarms.



**Note:** Subcooling alarms only validate with a fan running. Fixed hysteresis of 1°C/1°F

**F75 - Time to validate the subcooling alarm:**

This function is used to inhibit subcooling alarms for a period of time due to a possible variation in temperature.

**F76 - Low pressure alarm on P1 transducer:****F77 - High pressure alarm on P1 transducer:****F78 - Low pressure alarm on P2 transducer:****F79 - High pressure alarm on P2 transducer:**

Minimum and maximum limits for pressure alarms.

**F80 - Pressure alarm hysteresis:**

It is the difference in pressure between turning a pressure alarm on and off.

**F81 - Pressure alarm validation time:**

This function is used to inhibit pressure alarms for a period of time due to a possible variation in pressure.

**F82 - Inhibition time when pressure alarms are energized:**

During this time, the pressure alarms remain off, waiting for the system to enter working mode.

**F83 - Low temperature alarm on T1 sensor:****F84 - High temperature alarm on T1 sensor:****F85 - Low temperature alarm on T2 sensor:****F86 - High temperature alarm on T2 sensor:****F87 - Low temperature alarm on T3 sensor:****F88 - High temperature alarm on T3 sensor:****F89 - Low temperature alarm on T4 sensor:****F90 - High temperature alarm on T4 sensor:****F91 - Low saturation temperature alarm (P1 pressure transducer):****F92 - High saturation temperature alarm (P1 pressure transducer):**

Minimum and maximum limits for temperature alarms.

**F93 - Temperature alarm hysteresis:**

It is the temperature difference between turning a temperature alarm on and off.

**F94 - Time to validate the temperature alarms:**

This function is used to inhibit temperature alarms for a period of time due to a possible variation in temperature.

**F95 - Inhibit time when temperature alarms are energized:**

During this time, the temperature alarms remain off, waiting for the system to enter working mode.

**F96 - Number of automatic reset attempts:**

$\boxed{111}$  - Manual reset only

$\boxed{1}$  -  $\boxed{10}$  - Number of automatic reset attempts

$\boxed{1}$  - Always tries automatic reset

Number of automatic resets allowed within the range defined in  $\boxed{F98}$ .

The reset system allows the user to configure how many times the controller will attempt to start the system automatically (automatic reset) if the alarm condition persists, system control is turned off.

**F97 - Interval between automatic reset attempts:**

Time interval that the control will be turned off to attempt to reset the system.

**F98 - Automatic reset period:**

When exceeding the number of automatic resets allowed within the range defined in this parameter, the system displays the message  $\boxed{F91}$ , indicating that the system must be manually reset.

To do this, go to the access menu, via the  $\boxed{F}$  key, according to item 9.3.5 Manual system reset, select  $\boxed{F5E}$  and briefly press the  $\boxed{E}$  key to confirm.

**F99 - Operating mode of the digital input 1:****F100 - Operating mode of the digital input 2:****F101 - Operating mode of the digital input 3:****F102 - Operating mode of the digital input 4:** **FFF** - Digital input disabled. **1** - Temperature sensor (digital input 1=T1), (digital input 2=T2), (digital input 3=T3), (digital input 4=T4) **2** - NO contact - Control shutdown **3** - NC contact - Control shutdown **4** - NO contact - Eco mode **5** - NC contact - Eco mode **6** - NO contact - Night mode **7** - NC contact - Night mode **8** - NO contact - Manual suction mode **9** - NC contact - Manual suction mode **10** - NO contact - Manual discharge mode **11** - NC contact - Manual discharge mode **12** - NO contact - General manual mode **13** - NC contact - General manual mode **14** - NO contact - External low pressure alarm **15** - NC contact - External low pressure alarm **16** - NO contact - External high pressure alarm **17** - NC contact - External high pressure alarm **18** - NO contact - External suction alarm **19** - NC contact - External suction alarm **20** - NO contact - External discharge alarm **21** - NC contact - External discharge alarm **22** - NO contact - IQ module external alarm **23** - NC contact - IQ module external alarm **24** - NO contact - External alarm **25** - NC contact - External alarm **26** - NO contact - External low pressure failure **27** - NC contact - External low pressure failure **28** - NO contact - External high pressure failure **29** - NC contact - External high pressure failure **30** - NO contact - External suction failure **31** - NC contact - External suction failure **32** - NO contact - External discharge failure **33** - NC contact - External discharge failure **34** - NO contact - IQ module external failure **35** - NC contact - IQ module external failure **36** - NO contact - External failure **37** - NC contact - External failure**F103 - Displacement of the temperature indication of the T1 sensor (Offset):****F104 - Displacement of the temperature indication of the T2 sensor (Offset):****F105 - Displacement of the temperature indication of the T3 sensor (Offset):****F106 - Displacement of the temperature indication of the T4 sensor (Offset):**

Allows you to compensate for any deviations in the sensor reading, resulting from changing the sensor or changing the cable length.

**F107 - Lower Pressure Limit of P1 transducer (Pressure at 4mA):**

Pressure applied to P1 pressure transducer when it presents a current of 4mA at its output.

**F108 - Upper pressure limit of P1 transducer (Pressure at 20mA):**

Pressure applied to P1 pressure transducer when it presents a current of 20mA at its output.

**F109 - P1 transducer pressure indication displacement (Offset):**

Allows you to compensate for any deviations in the transducer reading, resulting from changing the transducer or changing the cable length.

 **Note:** The P1 pressure transducer can be turned off by adjusting the indication offset to the minimum value until the message **FFF** appears. In this condition, all functions dependent on P1 transducer reading cease to operate.

**F110 - Lower Pressure Limit of P2 transducer (Pressure at 4mA):**

Pressure applied to P2 pressure transducer when it presents a current of 4mA at its output.

**F111 - Upper pressure limit of P2 transducer (Pressure at 20mA):**

Pressure applied to P2 pressure transducer when it presents a current of 20mA at its output.

**F112 - P2 transducer pressure indication displacement (Offset):**

Allows you to compensate for any deviations in the transducer reading, resulting from changing the transducer or changing the cable length.

 **Note:** The P2 pressure transducer can be turned off by adjusting the indication offset to the minimum value until the message **FFF** appears. In this condition, all functions dependent on P2 transducer reading cease to operate.

**F113 - Enable buzzer:**

Enables or disables the internal buzzer to sound alarms.

**F114 - Preferred Indicator:** **1** - P1 transducer pressure **2** - P2 transducer pressure **3** - P1 transducer saturation temperature **4** - P2 transducer saturation temperature **5** - T1 sensor temperature **6** - T2 sensor temperature **7** - T3 sensor temperature **8** - T4 sensor temperature **9** - Temperature differential between T1 and T2 **10** - Temperature differential between T3 and T4 **11** - Superheat temperature (SH) **12** - Subcooling temperature (SC) **13** - Alternating display of sensors referenced to the control **14** - Alternating display of sensors referenced to control, superheating and subcooling**F115 - Function Lock Mode:**

Allows and configures function lock (see item 9.3.9).

 **0** - Does not allow function locking. **1** - Allows partial locking, where the control functions are locked but the setpoint adjustment remains enabled. **2** - Allows total locking.**F116 - Function Lock Period:**

Sets the time in seconds after the command that the functions will be locked.

 **15** -  **60** Time in seconds for the command to activate locking.**F117 - Shutdown of control functions:**

Authorizes the shutdown of control functions (see item 9.3.10).

 **FFF** - Does not allow control functions to be turned off. **1** - Allows you to turn control functions on and off only if the functions are unlocked. **2** - Allows you to turn control functions on and off even if the functions are locked.**F118 - Address of the Instrument on the RS-485 network:**

Address of the instrument on the RS-485 network that enables it to communicate with the Sitrad software.

 **Note:** You may not have any device on the network with the same address.

## 10. SUCTION CONTROL

### 10.1 Suction control associated with a VCC-analog compressor

With **[F03]** set to 1,2,3 or 4, suction is controlled only by a VCC-Analog compressor. In these options, the digital output OUT1 is used to control the Start of the VCC compressor. The analog output AN1 is used to drive frequency inverters or modules for controlling compressors that receive a signal between 0-10V. The control uses the VCC compressor setpoint value and hysteresis parameters.

Example:

- [F05]** Suction operating mode: 1 - Pressure (P1 pressure transducer)
- [F06]** Suction pressure setpoint: 25 psi
- [F09]** Variable suction pressure compressor hysteresis (analog output): 6 psi
- [F25]** VCC: Start time: 60s
- [F61]** Minimum value of analog output 1: 10%
- [F62]** Maximum value of analog output 1: 100%
- [F63]** Starting value of analog output 1: 15%

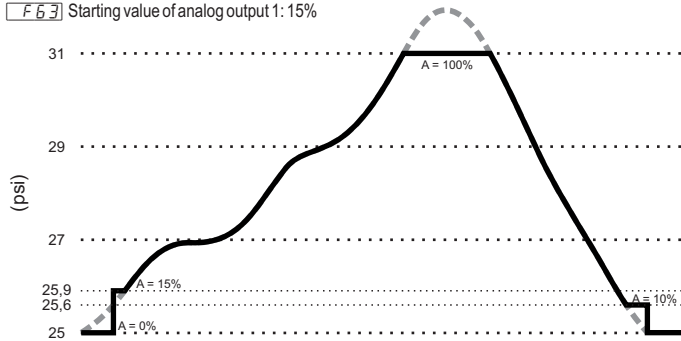

### 10.2 Suction control associated with a VCC-analog compressor in conjunction with an On/Off compressor

With **[F03]** set to 5,6 or 7, suction is controlled by a VCC-Analog compressor in conjunction with an On/Off compressor. In these options, the OUT1 digital output is intended for controlling the VCC compressor Start and the OUT2 output is intended for controlling the compressor On/Off. When the VCC-Analog compressor operates in conjunction with On/Off compressors, control is done through a setpoint value and two hysteresis.

The variable compressor hysteresis **[F09]** corresponds to the pressure range for controlling the VCC compressor output and the On/Off compressor hysteresis **[F08]** corresponds to the On/Off compressor control range.

The VCC-Analog compressor is the first to be activated and the last to be deactivated. There are validation times **[F26]** and **[F27]** for activating or deactivating the compressor when its upper or lower actuation limit is reached. When the On/Off compressor is turned on or off, the VCC compressor capacity is recalculated to compensate for the added or removed portion.

Example:

- [F05]** Suction operating mode: 1 - Pressure (P1 pressure transducer)
- [F06]** Suction pressure setpoint: 25 psi
- [F08]** Suction pressure compressor hysteresis ON/OFF (digital output): 4 psi
- [F09]** Variable suction pressure compressor hysteresis (analog output): 2 psi

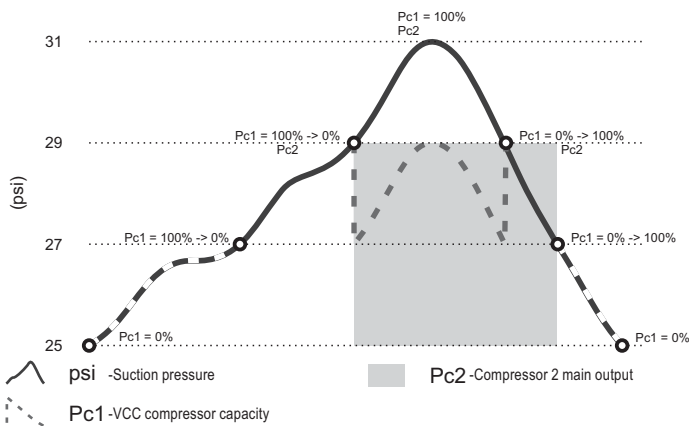

### 10.3 Suction control associated with On/Off compressor only

With **[F03]** set to 8,9,10,11 or 12, suction is controlled by On/Off compressors only. When using on-off compressors (ON/OFF), each compressor is associated with just one output, therefore, the step is equal to hysteresis by dividing the number of compressors.

Example:

- [F03]** Condensing unit configuration: 10 (suction controlled by 2 On/Off compressors)
- [F05]** Suction operating mode: 1 - Pressure (P1 pressure transducer)
- [F06]** Suction pressure setpoint: 25 psi
- [F08]** Suction pressure compressor hysteresis ON/OFF (digital output): 6 psi

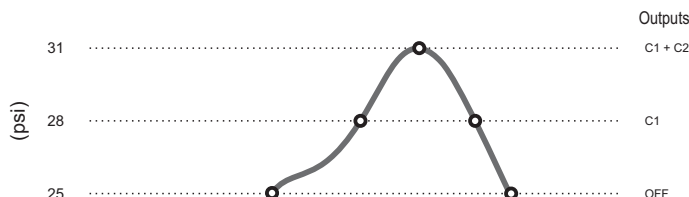

## 11. DISCHARGE CONTROLS

### 11.1 Discharge control associated with a fan with inverter modulation

With **[F07]** set to 3,6,11 or 12, the discharge is controlled only by a fan with inverter modulation. For each option, a digital output is used to control the Start of this fan.

Analog output AN2 is used to drive EC (Electronically Commutated) fans or frequency inverters to control fans that receive a signal between 0-10V.

The control uses the setpoint value and analog discharge hysteresis parameters.

Example:

- [F35]** Discharge operating mode: 1 - Pressure (P2 pressure transducer)
- [F36]** Discharge pressure setpoint: 250 psi
- [F38]** Discharge pressure variable fan hysteresis (analog output): 60 psi
- [F57]** Analog output starting time: 60s
- [F65]** Minimum value of analog output 2: 10%
- [F66]** Maximum value of analog output 2: 100%
- [F67]** Starting value of analog output 2: 15%

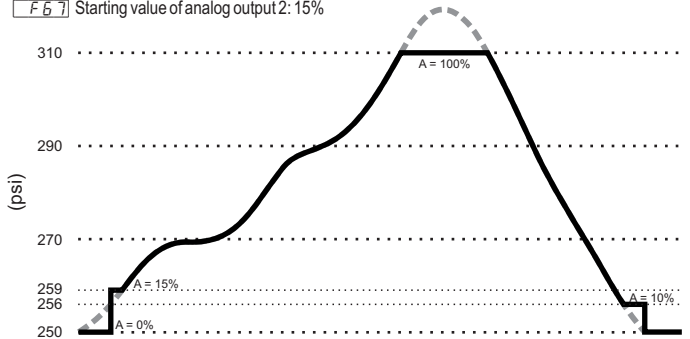

### 11.2 Discharge control associated with a fan (inverter) together with an On/Off fan

With **[F07]** set to 4 or 7, the discharge is controlled by an inverter fan in conjunction with an On/Off fan. When the fan (inverter) operates in conjunction with On/Off fans, control is done through a setpoint value and two hysteresis.

The inverter fan hysteresis **[F38]** corresponds to the pressure range for controlling the inverter fan output and the On/Off fan hysteresis **[F37]** corresponds to the On/Off fan control range.

The inverter fan is the first to be activated and the last to be deactivated. There are validation times **[F52]** and **[F53]** for activating or deactivating the fan when its upper or lower actuation limit is reached. When the On/Off fan is turned on or off, the inverter fan output is recalculated to compensate for the added or removed portion.

Example:

- [F35]** Discharge operating mode: 1 - Pressure (P2 pressure transducer)
- [F36]** Discharge pressure setpoint: 250 psi
- [F37]** Discharge pressure fan hysteresis ON/OFF (digital outputs): 40 psi
- [F38]** Discharge pressure variable fan hysteresis (analog output): 20 psi

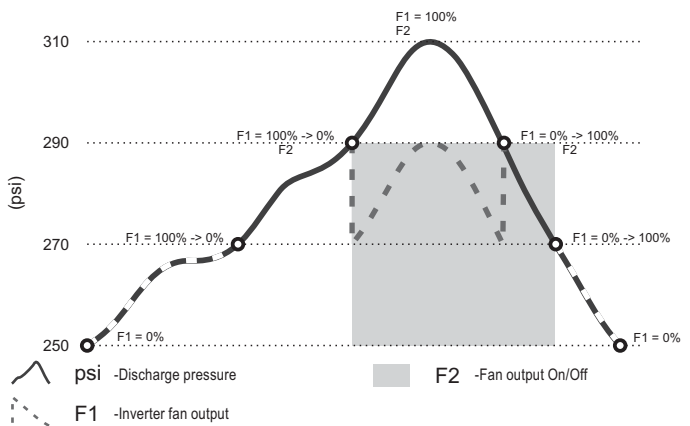

### 11.3 Discharge control associated with On/Off fans only

With **[F07]** set to 1,2,5,8,9 or 10, discharge is controlled by On/Off fans only. When using on-off fans (ON/OFF), each fan is associated with only one output, therefore, the step is equal to hysteresis divided by the number of fans.

Example:

- [F03]** Condensing unit configuration: 2 (discharge controlled by 2 On/Off fans)
- [F35]** Discharge operating mode: 1 - Pressure (P2 pressure transducer)
- [F36]** Discharge pressure setpoint: 250 psi
- [F37]** Discharge pressure fan hysteresis ON/OFF (digital outputs): 60 psi

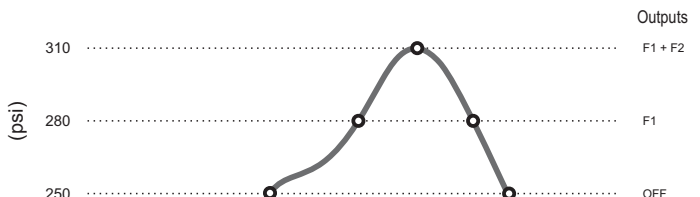

## 12. WARNINGS / ALARMS / ERRORS

### 12.1 Warnings

P-1	Pressure in P1 transducer (suction)
P-2	Pressure in P2 transducer (discharge)
ESA1	Saturation temperature referring to P1 pressure transducer (Suction)
ESA2	Saturation temperature related to P2 pressure transducer (Discharge)
T-1	Temperature in T1 sensor
T-2	Temperature in T2 sensor
T-3	Temperature in T3 sensor
T-4	Temperature in T4 sensor
TEE2	Temperature differential between T1 and T2
TEE4	Temperature differential between T3 and T4
DN5C	Capacity required by suction
PC5C	Power provided by suction
DN5S	Capacity required for discharge
PC5S	Power supplied by discharge
SH	Superheat indication
SC	Subcooling indication
ECO	Economic setpoint activated
 Led flashing	Night mode activated
MANSC	Manual suction mode activated
MANDS	Manual discharge mode activated
MAN	Manual mode
INHIB	Buzzer inhibited (sound alarm)
LOC	Function lock
UN	
LOC	Function unlock
OFF	
OFF	Control functions turned off
INF0	Error in preferential indication
RESET	Automatic reset time is elapsed

### 12.2 Alarms

ASHL	<b>Description:</b> Low superheat alarm. <b>Effect:</b> If [F5B] configured between 5 and 8, turns off all suction pressure switch compressors. Ignores the time between shutdowns. <b>Otherwise:</b> Indicative alarm.
ASHH	<b>Description:</b> High superheat alarm. <b>Effect:</b> Indicative alarm.
ASCL	<b>Description:</b> Low subcooling alarm. <b>Effect:</b> Indicative alarm.
ASCH	<b>Description:</b> High subcooling alarm. <b>Effect:</b> Indicative alarm.
ALP1	<b>Description:</b> Low pressure alarm on P1 pressure sensor. <b>Effect:</b> Turns off suction line compressors and discharge line fans, disregarding the time between activations.
ALP2	<b>Description:</b> Low pressure alarm on P2 pressure sensor. <b>Effect:</b> Indicative alarm.
CEP1	<b>Description:</b> Critical pressure alarm on P1 pressure sensor (temperature control). <b>Effect:</b> Case [F05] - Suction operating mode = Temperature sensor T1, Temperature sensor T2, Temperature sensor T3 or Temperature T4, turns off suction line compressors and discharge line fans, disregarding the time between activations. <b>Note:</b> this alarm only occurs if control is via a temperature sensor.
AHP1	<b>Description:</b> High pressure alarm in P1 pressure sensor. <b>Effect:</b> Indicative alarm.
AHP2	<b>Description:</b> High pressure alarm in P2 pressure sensor. <b>Effect:</b> Turns off suction compressors, disregarding the time between deactivations.
ALTE1	<b>Description:</b> T1 sensor low temperature alarm. <b>Effect:</b> Case [F05] - Suction operating mode = Temperature sensor T1: turns off suction compressors, disregarding the time between deactivations. <b>Otherwise:</b> indicative alarm.
ALTE2	<b>Description:</b> T2 sensor low temperature alarm. <b>Effect:</b> Case [F05] - Suction operating mode = Temperature sensor T2: turns off suction compressors, disregarding the time between deactivations. <b>Otherwise:</b> indicative alarm.

ALTE3	<b>Description:</b> T3 sensor low temperature alarm. <b>Effect:</b> Case [F05] - Suction operating mode = Temperature sensor T3: turns off suction compressors, disregarding the time between deactivations. <b>Otherwise:</b> indicative alarm.
ALTE4	<b>Description:</b> T4 sensor low temperature alarm. <b>Effect:</b> Case [F05] - Suction operating mode = Temperature sensor T4: turns off suction compressors, disregarding the time between deactivations. <b>Otherwise:</b> indicative alarm.
ALTE5	<b>Description:</b> Low saturation temperature alarm. <b>Effect:</b> Case [F05] - Suction operating mode = Saturation temperature (P1 pressure transducer): turns off suction compressors, disregarding the time between deactivations. <b>Otherwise:</b> indicative alarm.
AHE1	<b>Description:</b> T1 sensor high temperature alarm. <b>Effect:</b> Indicative alarm.
AHE2	<b>Description:</b> T2 sensor high temperature alarm. <b>Effect:</b> Indicative alarm.
AHE3	<b>Description:</b> T3 sensor high temperature alarm. <b>Effect:</b> Indicative alarm.
AHE4	<b>Description:</b> T4 sensor high temperature alarm. <b>Effect:</b> Indicative alarm.
AHE5	<b>Description:</b> High saturation temperature alarm. <b>Effect:</b> Indicative alarm.
EALP	<b>Description:</b> External low pressure alarm. <b>Effect:</b> Indicative alarm.
EALP	<b>Description:</b> External high pressure alarm. <b>Effect:</b> Indicative alarm.
EASC	<b>Description:</b> External suction alarm. <b>Effect:</b> Indicative alarm.
EADS	<b>Description:</b> External discharge alarm. <b>Effect:</b> Indicative alarm.
ECPN	<b>Description:</b> External alarm compressor control module. <b>Effect:</b> Indicative alarm.
EA	<b>Description:</b> External alarm. <b>Effect:</b> Indicative alarm.
EFLP	<b>Description:</b> External low pressure failure. <b>Effect:</b> Turns off suction and discharge control without respecting the times between turns off.
EFHP	<b>Description:</b> External high pressure failure. <b>Effect:</b> Turns off suction and discharge control without respecting the times between turns off.
EFSC	<b>Description:</b> External suction failure. <b>Effect:</b> Turns off suction control without respecting the times between turns off.
EFDS	<b>Description:</b> External discharge failure. <b>Effect:</b> Turns off discharge control without respecting the times between turns off.
FCPN	<b>Description:</b> External failure of the compressor control module. <b>Effect:</b> Turns off suction and discharge control without respecting the times between turns off.
EF	<b>Description:</b> External failure. <b>Effect:</b> Turns off suction and discharge control without respecting the times between turns off.
FAIL	<b>Description:</b> Automatic reset failed - number of attempts reached. <b>Effect:</b> Switch Off Control Functions. Wait for manual reset.

### 12.3 Errors

ECAL	<b>Description:</b> Contact Full Gauge. <b>Effect:</b> Locks control functions.
PPPP	<b>Description:</b> Reset function values. <b>Effect:</b> Locks control functions.
ECLD	<b>Description:</b> Clock not set. <b>Effect:</b> Indicative alarm.
ERP1	<b>Description:</b> Error in P1 pressure transducer (suction). <b>Effect:</b> Case [F05] - Suction operating mode = Pressure (P1 pressure transducer) or Saturation temperature (P1 pressure transducer): acts according to the configuration of parameter [F32] - Suction activation in case of failure of the sensor. <b>Otherwise:</b> indicative alarm.
ERP2	<b>Description:</b> Error in P2 pressure transducer (discharge). <b>Effect:</b> Case [F36] - Discharge operating mode = Pressure (P2 pressure transducer) or Saturation Temperature (P2 pressure transducer): acts according to the configuration of parameter [F5B] - Discharge activation in case of failure of the sensor. <b>Otherwise:</b> indicative alarm.
ERT1	<b>Description:</b> Error in T1 temperature sensor. <b>Effect:</b> Case [F05] - Suction operating mode = Temperature sensor T1 acts according to the configuration of parameter [F32] - Suction activation in case of sensor failure. Case [F36] - Discharge operating mode = Temperature sensor T1 acts in accordance with the parameter setting [F5B] - Discharge activation in case of sensor failure. <b>Otherwise:</b> indicative alarm.
ERT2	<b>Description:</b> Error in T2 temperature sensor. <b>Effect:</b> Case [F05] - Suction operating mode = Temperature sensor T2 acts according to the configuration of parameter [F32] - Suction activation in case of sensor failure. Case [F36] - Discharge operating mode = Temperature sensor T2 acts in accordance with the parameter setting [F5B] - Discharge activation in case of sensor failure. <b>Otherwise:</b> indicative alarm.

**Description:** Error in T3 temperature sensor.  
**Effect:** Case [ F 0 5 ] - Suction operating mode = Temperature sensor T3 acts according to the configuration of parameter [ F 3 2 ] - Suction activation in case of sensor failure. Case [ F 3 6 ] - Discharge operating mode = Temperature sensor T3 acts in accordance with the parameter setting [ F 5 8 ] - Discharge activation in case of sensor failure.  
**Otherwise:** indicative alarm.

**Description:** Error in T4 temperature sensor.  
**Effect:** Case [ F 0 5 ] - Suction operating mode = Temperature sensor T4 acts according to the configuration of parameter [ F 3 2 ] - Suction activation in case of sensor failure. Case [ F 3 6 ] - Discharge operating mode = Temperature sensor T4 acts in accordance with the parameter setting [ F 5 8 ] - Discharge activation in case of sensor failure.  
**Otherwise:** indicative alarm.

**13. GLOSSARY**

- °C: Temperature in degrees Celsius.
- °F: Temperature in degrees Fahrenheit
- LOC: Locked.
- No: No.
- OFF: Turned Off / Deactivated.
- ON: Turned On / Activated.
- SET: Setting.

**14. CONNECTING CONTROLLERS, RS-485 SERIAL INTERFACE AND COMPUTER**

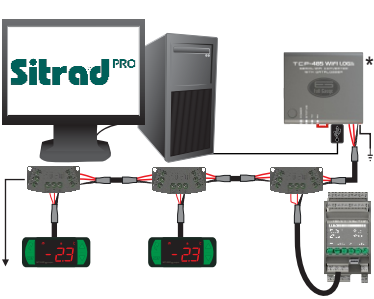

**\*INTERFACE SERIAL RS-485**  
 Device used to establish the connection of Full Gauge Controls instruments with Sitrad®.  
 Full Gauge offers different interface options, including technologies such as USB, Ethernet, Wifi, among others.  
 For more information, consult Full Gauge Controls. Sold separately.  
**MODBUS PROTOCOL**  
 The controller allows you to configure the RS-485 communication port for the MODBUS-RTU protocol. For more information about the implemented commands and the registration table, contact Full Gauge Controls.



**CONNECTION BLOCK**

It is used to connect more than one controller to the Interface. The wire connections must be made as follows: Terminal A of the controller connect to terminal A of the connection block, which in turn, must be connected to terminal A of the Interface. Repeat the procedure for terminals B and ½, being ½ the cable screen.

**15. OPTIONAL ITEMS - SOLD SEPARATELY**

**EasyProg - version 6 or higher**

This is an accessory, whose main function is to store the parameters of the controllers. You can load new parameters from a controller at any time, and download them to a production line (from the same controller), for example.

It has three types of connection for loading or clearing parameters:

- **Serial RS-485:** Connect it to the controller using the RS-485 network (only controllers that can access RS-485).

- **USB:** If connected to the computer by a USB port, it can use Sitrad's Program Editor.

- **Serial TTL:** The controller can connect directly to EasyProg by a Serial TTL connection.



**IMPORTANT**  
 IN ORDER TO COMMUNICATE WITH EASYPROG, THE EQUIPMENT MUST NOT BE LINKED TO SITRAD SOFTWARE.

**Extended Panel**

Full Gauge Controls extended panel allows controllers to be installed in Evolution and Ri lines, whose maximum size is 76x34x77mm (the opening must measure 71x29mm for the extended panel to be installed), as the opening does not need to be precise for the device to be properly installed. The panel has space to be branded with the company logo and contact information, and it has 10A switches (250 V ac) that can be used for switching on internal lighting, ventilation or fan systems.

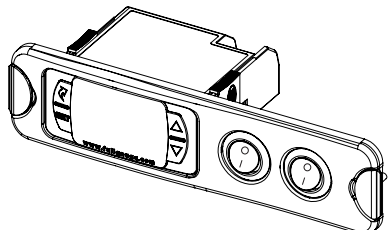

**16. ANNEXES - Reference Diagrams**

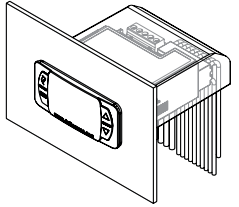
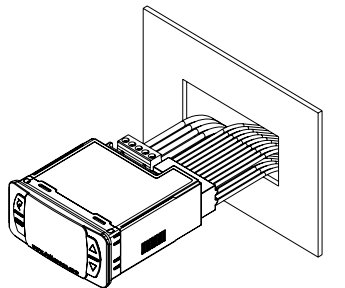
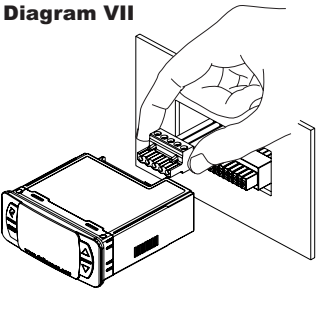
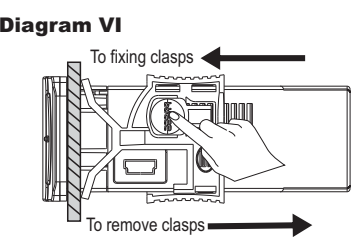
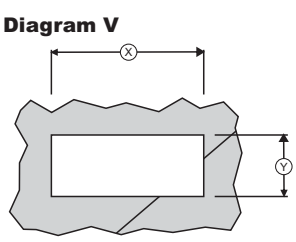

To ensure it is properly and safely installed, connect all leads before putting the controller in position.

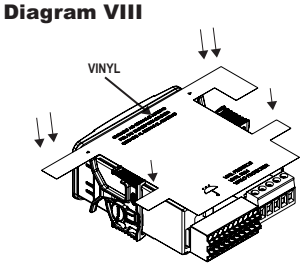

**17. WARRANTY**

**ENVIRONMENTAL INFORMATION**  
**Packaging:** Full Gauge products use packaging made from entirely recycled materials. Please dispose of it through specialized recyclers.  
**Product:** The components used in Full Gauge controllers can be recycled and reused if they are dismantled by specialists.  
**Disposal:** Do not burn or throw controllers in the domestic waste, once they have reached the end of their working life. Follow the current legislation applicable to your area in relation to disposing of electronic waste. If you have any questions, contact Full Gauge Controls.

Products manufactured by Full Gauge Controls, from May 2005, have a warranty period of 10 (ten) years direct from the factory and 01 (one) year from accredited retailers, starting from the consignment date on the sales invoice. After this year, the warranty will continue to be honored for purchases from retailers if the device is sent directly to Full Gauge Controls. This period is valid in Brazil. Other countries provide a guarantee for 2 years. The products are guaranteed in the event of a manufacturing fault that makes them unsuitable or inappropriate for the uses to which they were intended. The warranty is limited to the maintenance of devices manufactured by Full Gauge Controls, regardless of any other form of costs, such as any indemnity due to damage caused to other equipment.

**WARRANTY EXCEPTIONS**  
 The Warranty does not cover transport and / or insurance costs for sending products believed to have defects or to have malfunctioned to Technical Support. The following events are also not covered: natural wear of parts, external damage caused by falls or improper packing of products.

**LOSS OF WARRANTY**  
 The product will automatically no longer be covered if:  
 -The instructions for use and assembly contained in the technical description and installation procedures listed in the NBR5410 standard are not observed;  
 -It is subjected to conditions beyond the limits specified in its technical description;  
 -If it is opened up or repaired by a person who is not part of Full Gauge's technical team;  
 -The damage which has taken place was the result of a fall, blow or impact, water damage, electrical surge or atmospheric discharge.

**USING THE WARRANTY**  
 To take advantage of the warranty, the customer must send the product properly packed, together with the corresponding purchase invoice, to Full Gauge Controls. The delivery cost for the product is borne by the client. You will also need to send as much information as possible regarding the defect that has been detected, thus making it possible to streamline the analysis, testing and servicing.  
 These processes and any eventual maintenance of the product will only be carried out by Full Gauge Controls' Technical Support, at the Company's head office - Rua Júlio de Castilhos, 250 - Zip Code 92120-030 - Canoas - Rio Grande do Sul - Brazil.

Rev. 03