



VX-1005E Ver.01

DIGITAL REFRIGERATION CONTROLLER WITH INTEGRATED MODULE FOR AN ELECTRONIC EXPANSION VALVE



VX1005EPLV01-04T-19717

Have this manual in the palm of your hand through the FG Finder app.

- Fast Freezing
- Function Lock
- Switch off Control Functions
- Electronic Expansion Valve
- Modbus Protocol
- Programming in Series
- Monitoring System
- IP 65 FRONT
- Degree of protection
- Quick coupling connection
- Variable compressor

1. DESCRIPTION

The VX-1005E is a digital temperature controller for refrigeration that has a digital output for actuating an electronic expansion valve (EEV). In this way, it acts in superheating control in order to optimize the energy efficiency of the controlled refrigeration system. It's a compact and integrated controller that offers a complete solution for controlling electronic expansion valves. It has a dedicated control algorithm to run the cooling process more efficiently without using the pressure transducer.

In addition to estimated superheat control, the instrument controls room temperature, defrosts, ventilation, lighting and alarms. Room temperature control has an economical setpoint, in addition to fast-freezing functionality. It adds the control of variable capacity compressors (VCC - Variable Capacity Compressor), providing a series of benefits to the refrigeration system, such as: reduction of energy consumption, less temperature oscillation, greater speed in reaching the desired temperature. By configuring its parameters, it's possible to make the controller compatible with the main brands of variable compressors on the market. For better use of energy, ventilation can be controlled during the off-cycle of the compressor and use Smooth Defrost, a defrosting technique that reduces the final temperature of the electrical resistance and the amount of heat emitted.

It has a serial communication output for integration with Sitrad, an internal real-time clock that allows programming of defrost events, an intelligent function blocking system, a way to turn off control functions. In addition, it has a digital filter functionality on the temperature sensor, which aims to simulate a mass increase in the environment sensor (S1), thus increasing its response time (thermal inertia) and preventing unnecessary compressor start-ups. The VX-1005E allows you to configure the RS-485 communication port for the MODBUS-RTU protocol. For more information about the implemented commands and the registration table, contact Full Gauge Controls.

2. SAFETY RECOMMENDATIONS

- Make sure that the controller assembling is done properly;
- Make sure that the power supply is turned off and not turned on during controller installation;
- Read this manual before installing and using the controller;
- Use appropriate Personal Protective Equipment (PPE);
- Install the vinyl adhesive protector (included) in installations prone to water splashes, such as refrigerated counters, etc.;
- Installation procedures must be performed only by licensed technicians, subject to codes and regulations.

3. APPLICATIONS

- Beverage displays and Display Cases.

4. TECHNICAL SPECIFICATIONS

Power supply	90 ~ 240Vca (50/60Hz)
Average consumption	6 VA
Temperature control range	-50 a 105°C / -58 a 221°F
Temperature resolution	0,1°C / 0,1°F
Working temperature	-20 a 60°C / -4 a 140°F
Working Humidity	10 a 90% RH (without condensation)
Digital input	Configurable dry contact type
Clock (RTC)	Energy backup: CR1220 battery Time keeping for up to 10 years Accuracy: ±6 minutes/year
Frequency output	10Vcc (± 10%)50mA max. 0...300Hz (duty-cycle = 50%)
Degree of protection	IP 65 (front)
Maximum Sizes	76 x 34 x 94mm / 2,99" x 1,33" x 3,70" (WxHxD)
Bay Size	X = 71±0,5mm(2,79"±0,02") Y = 29±0,5(1,14"±0,02") (See Diagram 5)
Output capacity	
COMP	120-240 Vac, 12 A Resistive, 100k cycles 120-240 Vac, 8 A General Use, 100k cycles 240 Vac, 1 HP, 100k cycles 120 Vac, 1/2 HP, 100k cycles
DEFR	120-240 Vac, 5 A Resistive
FAN	240 Vac, 1/8 HP 120 Vac, 1/10 HP
AUX / LIGHT	240 Vac, 1/8 HP 120 Vac, 1/10 HP 120-240Vac 5W General Use

5. DISPLAY AND KEYS

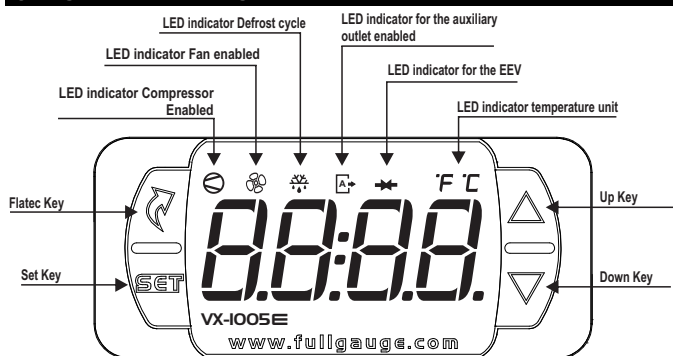

6. INSTALLATION - PANEL AND ELECTRICAL CONNECTIONS

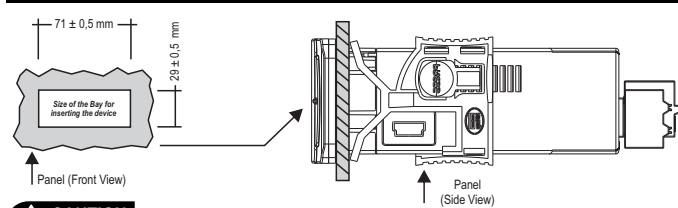

CAUTION

WHERE THE INSTALLATION LOCATION NEEDS TO BE SEALED AGAINST LIQUIDS, THE OPENING IN WHICH THE CONTROLLER IS TO BE INSTALLED MUST BE NO MORE THAN 70.5x29mm. THE SIDE CLASPS MUST BE SECURED IN SUCH A WAY AS TO CREATE A TIGHT RUBBER SEAL THAT PREVENTS ANY LIQUIDS ENTERING THE OPENING AND THE CONTROLLER.

7. CONNECTION DIAGRAM

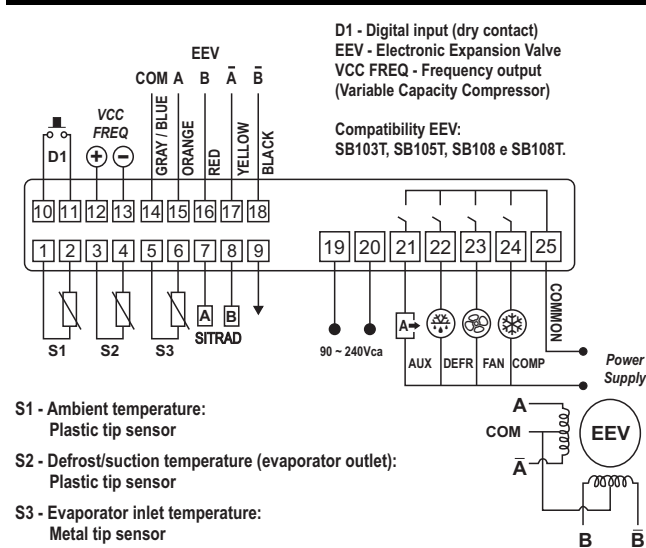

7.1. Considerations for installing temperature sensors

- Position sensor S2 - Defrost/suction sensor close to the evaporator output (5cm).
- Due to the position of the defrost sensor at the evaporator output, set the defrost end temperature (Parameter [F4]) lower than the setting normally performed.
- Position sensor S3 - Evaporator input sensor, after the electronic expansion valve (10cm).
- Fix the temperature sensors firmly and thermally insulate them so that the room temperature doesn't interfere with the measurement of the liquid refrigerant temperature.

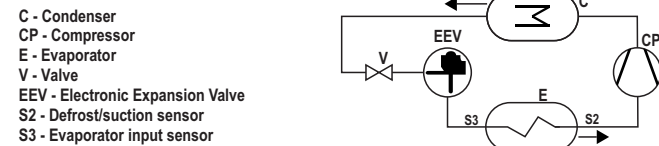

NEW CONNECTION SYSTEM (QUICK CONNECTOR): PUSH-IN WIRE CONNECTORS - QUICKLY

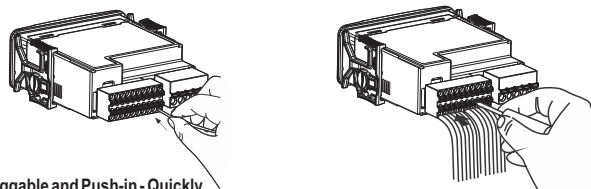

Pluggable and Push-in - Quickly

- Push-in Connection:
 - Hold the wire close to its end and insert it into the required opening.
 - If necessary, press the button to help make the connection.
 - Ferrule type terminals can be used.
 - For the signal connections, the ferrule must be at least 12mm.
- In the power connectors the pin must be at least 7mm.

NOTES 1 - Signal Connectors:

- Connections 1 to 18 must use wire of a gauge between 0.2 and 1,5mm² (26 and 16AWG).

NOTES 2 - Power Connectors:

- Connections 19 to 25 must use wire of a gauge between 0.2 and 2.5mm² (26 and 12AWG).

TO DISCONNECT THE PUSH-IN CONNECTION:

- To disconnect the wire, press the button and remove it.

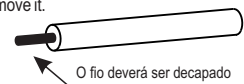

O fio deverá ser decapado



Terminal Rocket Pin.

7.2. Connecting the temperature sensors

- Connect the wires of the **S1 Sensor** to terminals "1 and 2", the wires of the **S2 sensor** to terminals and "3 and 4" and the wires of the **S3 sensor** to terminals "5 and 6"; the polarity is indifferent.
- The length of the sensor cables can be increased by the user themselves up to 200 meters (650 ft.), using a 2x24 AWG PP cable.

7.3. Recommendations from NBR5410 and IEC60364 standards

- Install surge protectors to the controller's power supply.
- Install transient suppressors - suppressor filter (type RC) - in the circuit to increase the working life of the controller's relay.
- The sensor cables can be together, but not in the same conduit as the power supply for the controller or the loads.

8. INSTALLATION PROCEDURE

- Cut out the panel plate (Diagram 5 - Item 15) where the controller is going to be installed, to a size where $X = 71 \pm 0,5$ mm and $Y = 29 \pm 0,5$ mm;
- Remove the side clasps (Diagram 6 - Item 15); to do this, press on the elliptical central part (with the Full Gauge Controls Logo) and slide the clasps back;
- Pass the wires through the opening (Diagram 7 - Item 15) and install the electrics as described in item 6;
- Insert the controller into the opening made in the panel, from the outside;
- Replace the clasps and move them until they are pressed against the panel, securing the controller to the housing (see arrow in Diagram 6 - Item 15);
- Adjust the parameters as described in item 9.

⚠ WARNING: Where the installation needs to be sealed tight against liquids, the opening for the controller must be no more than 70.5x29mm.

The side clasps must be secured in such a way as to create a tight rubber seal that prevents any liquids entering the opening and the controller.

Protective Film - Diagram 8 (item 15)

This protects the controller when it is installed somewhere subject to splashing water, such as refrigerated counters.

⚠ IMPORTANT: Only apply it after you have finished making the electrical connections:

- Pull the side clasps back (Diagram 6 - item 15);
 - Remove the protective film from the adhesive vinyl strip;
 - Apply the film to the entire upper part, folding the flaps, as indicated by the arrows - Diagram 9 (item 14);
 - Replace the clasps.
- Note: The film is transparent, so that the electrical layout of the device can be seen.

9. OPERATIONS

9.1 Access Menu Map

Press the Access key **A** (short touch) to navigate through the menu functions. Each press will display the next function in the series. To confirm press the **OK** key (short touch). The menu function map is below:

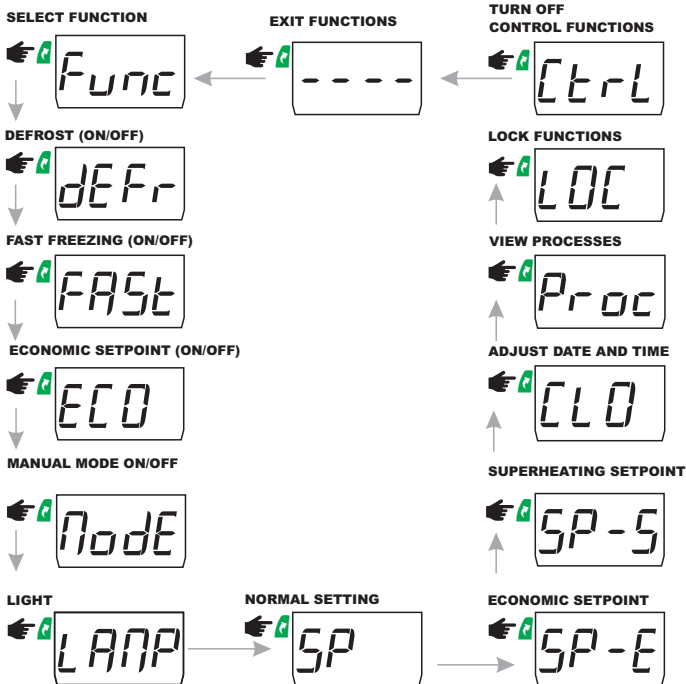

9.2 List of key functions

The keys listed act as shortcuts for the following functions:

	Brief press: The current day, month, year, day of the week, hour and minutes will be shown in sequence on the display.
	Press for 2 seconds: Adjust the Setpoints
	Brief press: Displays maximum and minimum temperatures / pressures.
	Press for 2 seconds: When displaying saved information, wipes the entry.
	Press for 4 seconds: Starts Manual Defrost.
	Press for 2 seconds: Stops warning alarms.
	Press for 4 seconds: Switches to displaying the measurements / processes briefly.
	Enter the Access Menu
	Press for 5 seconds: Turns off control functions.
	Enters select function.

9.3 Basic Operation

9.3.1 Operation mode

To enter the setpoint adjustment menu, press **OK** for 2 seconds. The message **[5P]** will appear on the display, followed by the value for adjusting the normal setpoint. Use the **▲** or **▼** keys to change the value and confirm by pressing **OK**. Next the message **[SP-E]** will be displayed showing that the economic setpoint to be changed. Again, use the **▲** or **▼** keys to change the value and confirm by pressing. Finally, the display will read **[---]** to show that configuration is complete. Setpoints can also be changed individually in the access menu.

9.3.2 Economic Setpoint (SPE)

The **[SP-E]** uses more flexible parameters for controlling the temperature which results in better energy savings (**[TDB]** - Desired temperature - Economic setpoint and **[T2]** - Switching differential - Economic setpoint (hysteresis)).

When it is active the message **[EED]** is displayed, alternating with the temperature and other messages.

Economy mode can be activated or deactivated using the commands:

Function	Command	Ação
[F15] [F16] [F17]	Time to come on	Activate
[F18]	Maximum temperature in economic mode	Desactive
[F18]	Maximum temperature in economic mode = 0 (Off)	Not dependent on time, only deactivated when door is opened
[F55] = [1] or [2]	Indicates door is open (digital input)	Keep turned off
[F55] = [1] or [0]	External key (digital input)	Activate / Deactivate
[F58]	Time to activate after door is closed	Activate
-	Determined by the Access Menu ([EED])	Activate / Deactivate
-	Error measuring ambient temperature (S1)	Keep turned off
-	On switching on the instrument	Deactivate
-	Fast Freezing	Deactive

9.3.3 Manual defrost

The defrosting process can be activated / deactivated manually through the access menu, using the **[DEFr]** option or by pressing the **▲** key for 4 seconds or by using an external switch connected to digital input (**[F55]** = 11 or 12). Activation or deactivation is indicated by the message **[DEFr]** **[On]** or **[DEFr]** **[Off]** respectively.

9.3.4 How to determine when defrosting is complete using the temperature

- Set the condition for starting defrosting as based on time, **[F29]** = 1;
- Reset the functions related to the end of defrosting to their maximum value:
 - Refrigeration time (Interval between defrosting periods) **[F29]** = 9999min.
 - Temperature of the Evaporator to finish the defrost **[F44]** = 105°C / 221°F
 - Maximum time on defrost (for safety) **[F46]** = 999min.
- Wait a while until a layer of ice has formed on the evaporator.
- Defrost manually (using the **A** key, go to **[DEFr]** and press **OK** or press the **▲** key for 4 seconds).
 - Monitor it melting.
 - Wait until all the ice on the evaporator has melted to determine when the defrosting is over.
 - When the defrosting has finished, check the temperature in the evaporator (S2) using the **▼** key (see item 9.3.9).
 - Using the reading for S2, adjust the temperature to end the defrosting:
 - Temperature of the evaporator to finish the defrost **[F44]** = Temp. S2
 - As a safety measure, reset the maximum defrost duration, according to the type of defrosting set.
 - Electric defrost (by resistance) **[F46]** = 45min.
 - Hot gas defrost **[F46]** = 20min.
 - Finally, adjust the refrigeration time (Interval between defrosts) **[F29]** to the desired value.

9.3.5 Fast Freezing

In fast freezing mode, the refrigeration output is permanently on and therefore the refrigeration or freezing process is accelerated. This operating mode can be activated or deactivated in the access menu, using option **[F5E]** or an external switch connected to the digital input (**[F55]** = 9 or 10). It can also be switched off automatically according to temperature **[F19]** or time **[F20]**. While fast freezing is on, the connected compressor display will flash rapidly and defrosting will continue. If, on activating the fast freezing mode, the controller identifies that there is a defrost cycle programmed to start during this period of time, the defrost will be run first and then it will go into fast freezing mode.

9.3.6 Turn Light On/Off

Using option **[LAMP]**, in the access menu, it is possible to turn the lamp on/off manually if the AUX output is configured as a lamp (**[F60]** = 1) and the defrosting of the tray is not configured to use the AUX output (**[F36]** = 2).

Note: When switching on the lamp manually, the time for when the lamp will be switched off after the door is closed **[F59]** will be reset.

9.3.7 Adjust date and time

The date and time can be adjusted using option **[CLO]**, from the access menu. This option is accessed with the **A** (Flatec) and confirmed with the **OK** key.

In the date and time setting mode, use the **▲** or **▼** keys to change the value and, when ready, press **OK** to store the value set. If the date entered is invalid, the message **[EED]** will appear on the display.

9.3.8 View date and time

By briefly pressing the **OK** key (brief press), the date and time set on the controller will be displayed. The current date (**[--d]**), month (**[--M]**), year (**[--y]**), day of the week (**[dRy-]**), hour and minutes (**[00:00]**) will be shown in sequence on the display.

9.3.9 View the stage of the process, the time elapsed and other measurements

The temporary display mode can be activated through the access menu using option [P r o c] or by pressing the [] key for 4 seconds until the message [P r o c] is displayed. The message on the current process will alternate with the length of time ([h:h:mm]) that has elapsed for this stage.

Stages of the process:

- [i n i t] - Initializing the Electronic Expansion Valve;
- [d e l] - Initial Delay (delay in starting up the instrument);
- [F a n] - Fan-delay (delay caused by the fan);
- [r e f r] - Refrigeration;
- [P r e] - Pre-Defrost;
- [d e f r] - Defrost;
- [d r a i] - Draining;
- [C o n t] - Control Functions are turned off;

In this viewing mode, it is also possible to view other measurements (if available) by pressing the [] key or the [] (short touch), depending on the list:

- [P r o c] - Process stage and time taken;
- [t - 1] - Temperature from the ambient sensor S1;
- [t - 2] - Temperature from the Evaporator sensor S2;
- [t - 3] - Temperature from the Suction Line sensor S3;
- [F r] - Variable compressor frequency;
- [S H] - Superheating Temperature;
- [U E E] - Percentage that the Electronic Expansion Valve has been opened.

The message related to the chosen measure will alternate with the measurement value.
Note: This display will remain on the display for 15 minutes or until the [] key or the [] (short touch).
Note: In this mode, alarm messages and the preferred display ([F 7 5]) will be ignored.

9.3.10 Function Lock

The function lock provides some extra safety when using this device. When it is enabled the normal and economic setpoints and other parameters can be viewed, but are not able to be changed ([F 7 8]=2) or you can just lock the device against changes to the control functions but allow the normal and economic setpoints to be amendable ([F 7 8]=1). To block the functions, access the [L o c k] option from the access menu using the [] (Flatec) key and confirm it by pressing the [] key. The message [L o c k] will be displayed if the lock is disabled. Now press and hold the [] key for the time configured for this function [F 7 9]. When enabled, the message [L o c k] [O n] will displayed. It can only be enabled if the function [F 7 8] is set to 1 or 2.

To disable the lock, turn the controller off and on again with the [] key pressed. Keep the key pressed until the message [L o c k] [O f f] indicates that it has been unlocked (10 seconds).
Note: Regardless of the values of [F 7 8] and [F 7 9] you are always able to adjust the time and hour.

9.3.11 Turn off control Functions

Turning off the control functions allows the controller to be used as a temperature / pressure indicator only, with the control outputs and alarms off. This feature can be enabled or disabled using the function. Shutdown of control functions [F 8 0]. When enabled, the control and alarm functions are turned off ([L o c k] [O f f]) or turned on ([L o c k] [O n]) using the menu provided by the option [L o c k]. When the control functions are turned off, the message [O f f] will be displayed, alternating with the temperature and other messages. It is also possible to switch off and on the control functions by pressing the [] for 5 seconds.
Note: When restarting the control functions, the instrument will go to the initial stage [i n i t].

9.5 Table of Parameters

	Fun	Description	CELSIUS (°C)				FAHRENHEIT (°F)			
			Min	Max	Unit	Standard	Min	Max	Unit	Standard
SUPERHEATING	[F 0 1]	Access code	0	999	-	0	0	999	-	0
	[F 0 2]	Type of Application (Reserved)	0	0	-	0	0	0	-	0
	[F 0 3]	Estimated Superheating Setpoint	0,0	50,0	°C	8,0	0,0	90,0	°F	14,4
	[F 0 4]	Liquid Refrigerant (Reserved)	0	0	-	0	0	0	-	0
	[F 0 5]	Lower Pressure Limit of the P1 transducer (Pressure at 4mA) (Reserved)	0	0	-	0	0	0	-	0
	[F 0 6]	Upper Pressure Limit of the P1 transducer (Pressure at 20mA) (Reserved)	0	0	-	0	0	0	-	0
REFRIGERATION	[F 0 7]	Desired Temperature - Normal Setpoint	F09	F10	°C	-23,0	F09	F10	°F	-9,4
	[F 0 8]	Desired Temperature - Economic Setpoint	F09	F10	°C	-18,0	F09	F10	°F	-0,4
	[F 0 9]	Minimum Setpoint allowed by the end user	-50,0	F10	°C	-50,0	-58,0	F10	°F	-58,0
	[F 1 0]	Maximum Setpoint allowed by the end user	F09	105,0	°C	105,0	F09	221,0	°F	221,0
	[F 1 1]	Control differential - Normal setpoint (hysteresis)	0,1	20,0	°C	2,0	0,1	36,0	°F	3,6
	[F 1 2]	Control differential - Economic setpoint (hysteresis)	0,1	20,0	°C	2,0	0,1	36,0	°F	3,6
	[F 1 3]	Pump Down Pressure or evaporator pressure setpoint (Reserved)	0	0	-	0	0	0	-	0
	[F 1 4]	Maximum Time for Pump Down (Reserved)	0	0	-	0	0	0	-	0
	[F 1 5]	Time for Economic Mode to begin (Monday to Friday)	00:00	24:00(Off)	hh:mm	24:00(Off)	00:00	24:00(Off)	hh:mm	24:00(Off)
	[F 1 6]	Time for Economic Mode to begin (Saturday)	00:00	24:00(Off)	hh:mm	24:00(Off)	00:00	24:00(Off)	hh:mm	24:00(Off)
	[F 1 7]	Time for Economic Mode to begin (Sunday)	00:00	24:00(Off)	hh:mm	24:00(Off)	00:00	24:00(Off)	hh:mm	24:00(Off)
	[F 1 8]	Maximum time in economic mode	0(Off)	999	minutes	120	0(Off)	999	minutes	120
	[F 1 9]	Fast Freezing Temperature Limit	-50,0	60,0	°C	-25,0	-58,0	140,0	°F	-13,0
	[F 2 0]	Maximum Fast Freezing time	0(Off)	999	minutes	300	0(Off)	999	minutes	300
	[F 2 1]	Minimum time for compressor to be on	0(Off)	9999	seconds	0(Off)	0(Off)	9999	seconds	0(Off)
	[F 2 2]	Minimum time for the compressor to be off	0(Off)	9999	seconds	0(Off)	0(Off)	9999	seconds	0(Off)
	[F 2 3]	Length of time the compressor is on, if there is an error from the S1 sensor	0(Off)	999	minutes	20	0(Off)	999	minutes	20
	[F 2 4]	Length of time the compressor is off, if there is an error from the S1 sensor	0(Off)	999	minutes	10	0(Off)	999	minutes	10
	[F 2 5]	Control Action if there is an error in the superheating sensors pressure transducer	0(Off)	1(Man)	-	1(Man)	0(Off)	1(Man)	-	1(Man)
	[F 2 6]	Delay time when powering up the controller	0(Off)	999	minutes	1	0(Off)	999	minutes	1

9.3.12 Record of maximum and minimum temperatures

Pressing the [] key (short touch) during the temperature / pressure display, the message [r e g] will appear and then the minimum and maximum temperatures and pressure recorded.
Note: If the [] key is pressed during the display of the records, the values will be reset and the message [r e g] will be displayed.

9.3.13 Selecting the temperature units

To select the units that the device will use, use function [F 0 1] with access code [2 3 1] and press the [] key. Next, select the required temperature unit [°C] or [°F] using the [] keys and confirm by pressing []. Whenever the units are changed, the function settings revert to the factory value and will therefore need to be reset.

9.4 Advanced Operations

9.4.1 Schedule Defrosting

You can configure the defrosting schedule to be equally distributed across the day by programming the number of defrost cycles per day. To do this, you need to set the start of the defrosting as part of a defrosting schedule, setting [F 2 8] to 5, and configuring functions [F 3 7] to [F 4 2] to determine the number of defrost cycles per day and their starting times. With this, the defrost schedule makes it possible to create a program from Monday to Friday, another program for Saturday and another for Sunday.
Example: If the program for Monday to Friday consists of a preferred time of 1 pm (and the number of defrosting cycles is 4, with an interval of 6 hours), the defrost schedule will operate at 1:00 am, at 7:00 am, at 1:00 pm and at 7:00 pm on each day.

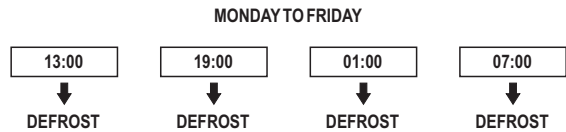

Note: If the condition for the start of the defrost cycle is set by the defrosting schedule and the clock is not set or disabled, the start of the defrost cycle will be based on time.

9.4.2 Electronic Expansion Valve in Manual Mode

You can switch the mode of the electronic expansion valve between manual and automatic, using the menu provided by the [M o d e] option. In manual mode, the message [M a n] is displayed, alternating with the temperature and other messages, and the electronic expansion valve remains fixed in the position configured in ([C 1 9] - Initial Valve Opening). In automatic mode, the controller checks the reading of the temperature and pressure sensors and calculates the value of the valve opening to ensure that the refrigeration system is as energy efficient as possible. In manual mode, the controller keeps the position of the VEE fixed according to the adjustment made.

9.4.3 Change the Parameters of the Controller

The function menu can be accessed through the access menu, option [F u n c] or by simultaneously pressing [] and [] while the pressure is being displayed. To allow these parameters to be changed, enter [F 0 1] by pressing [] (short touch) and by using the [] or [] keys to enter the code 123 (one hundred and twenty-three) and confirm with the [] key. To change the other functions, navigate the menu using the [] or [] keys and use the same method to adjust them. To exit the menu and return to normal activity, press [] (long press) until [---] is displayed.
Note: To access the settings for the parameters of the electronic expansion valve [C 0 1] to [C 0 2] enter code 717 and confirm with [].
Note: To access the variable compressor configuration parameters [C P 0 1] to [C P 1 9] enter code 718 and confirm with [].
Note: If the function lock is on, the controller will display the message [L o c k] on the display, when the [] or [] keys are pressed, and will not allow any adjustment to the parameters.

	Fun	Description	CELSIUS (°C)				FAHRENHEIT (°F)			
			Min	Max	Unit	Standard	Min	Max	Unit	Standard
DEFROST	F27	Defrost type (0 = resistance / 1 = hot gas / 2 = natural)	0	2	-	0	0	2	-	0
	F28	Condition for starting	0(Off)	5	-	1	0(Off)	5	-	1
	F29	Interval between defrosting periods if F28=1 or the Maximum time without defrosting if F28= 2, 3 or 4	1	9999	minutes	480	1	9999	minutes	480
	F30	Additional time to the end of the first refrigeration cycle	0(Off)	999	minutes	0(Off)	0(Off)	999	minutes	0(Off)
	F31	Temperature of the evaporator (sensor S2) in order to begin defrost if F28= 2 or 4	-50,0	105,0	°C	-20,0	-58,0	221,0	°F	-4,0
	F32	Temperature Difference in order to start defrosting (S1-S2) if F28= 3 or 4	-50,0	105,0	°C	15,0	-58,0	221,0	°F	59,0
	F33	Time to confirm to start the pre-defrost setting if F28=2, 3 or 4	0(Off)	999	minutes	10	0(Off)	999	minutes	10
	F34	Defrost when the controller is powered on	0(Off)	1(On)	-	1(On)	0(Off)	1(On)	-	1(On)
	F35	Smooth Defrost if F27=0	10	100(Off)	-	100(Off)	10	100(Off)	-	100(Off)
	F36	Enable Tray Defrost	0(Off)	2	-	0(Off)	0(Off)	2	-	0(Off)
	F37	Number of Defrostings per day (Monday to Friday) if F28=5	1	12	-	4	1	12	-	4
	F38	Time to start Defrost (Monday to Friday) if F28=5	00:00	23:59	hh:mm	06:00	00:00	23:59	hh:mm	06:00
	F39	Number of Defrostings per day (Saturday) if F28=5	1	12	-	4	1	12	-	4
	F40	Time to start Defrost (Saturday) if F28=5	00:00	23:59	hh:mm	06:00	00:00	23:59	hh:mm	06:00
	F41	Number of Defrostings per day (Sunday) if F28=5	1	12	-	4	1	12	-	4
	F42	Time to start Defrost (Sunday) if F28=5	00:00	23:59	hh:mm	06:00	00:00	23:59	hh:mm	06:00
	F43	Length of pre-defrost (collecting in gas)	0(Off)	999	minutes	0(Off)	0(Off)	999	minutes	0(Off)
	F44	Temperature of the Evaporator (S2 sensor) to finish the defrost	-50,0	105,0	°C	15,0	-58,0	221,0	°F	59,0
	F45	Ambient temperature (S1 sensor) required to end the defrost	-50,0	105,0	°C	5,0	-58,0	221,0	°F	41,0
	F46	Maximum time on defrost (for safety)	1	999	minutes	30	1	999	minutes	30
F47	Draining time (from water collected from defrosting)	0(Off)	999	minutes	3	0(Off)	999	minutes	3	
FAN	F48	Fan operation mode	0	4	-	3	0	4	-	3
	F49	Time fan is on if F48=0 or 4	1	999	minutes	2	1	999	minutes	2
	F50	Time fan is turned off if F48=0 (automatic timed mode)	1	999	minutes	8	1	999	minutes	8
	F51	Length of time door is open until fan is turned off F55=1 or 2	-1(Off)	9999	seconds	0	-1(Off)	9999	seconds	0
	F52	Fan cut off due to high temperature in the evaporator (S2 sensor)	-50,0	105,0	°C	10,0	-58,0	221,0	°F	50,0
	F53	Temperature in the evaporator to switch the fan back on after draining	-50,0	105,0	°C	-5,0	-58,0	221,0	°F	23,0
F54	Maximum length of time until the fan is switched back on after drainage (fan-delay)	0(Off)	999	minutes	1	0(Off)	999	minutes	1	
DOOR	F55	Function mode of the digital input	0(Off)	12	-	2	0(Off)	2	-	2
	F56	Length of time door is open for instant defrost if F55=1 or 2	0(Off)	999	minutes	30	0(Off)	999	minutes	30
	F57	Length of time door is open until fan and compressor are turned off F55=1 or 2	0(Off)	999	minutes	5	0(Off)	999	minutes	5
	F58	Length of time door is closed until economic mode is activated if F55=1 or 2	0(Off)	999	minutes	0(Off)	0(Off)	999	minutes	0(Off)
F59	Length of time door is closed until light is switched off is F55=1 or 2 and F60=1	0(Off)	999	minutes	2	0(Off)	999	minutes	2	
ALARMS	F60	AUX output mode	0	2	-	1	0(Off)	2	-	1
	F61	Low ambient temperature alarm (S1 sensor)	-50,0	105,0	°C	-50,0	-58,0	221,0	°F	-58,0
	F62	High ambient temperature alarm (S1 sensor)	-50,0	105,0	°C	105,0	-58,0	221,0	°F	221,0
	F63	Time to confirm the alarm by room temperature (S1)	0(Off)	999	minutes	0(Off)	0(Off)	999	minutes	0(Off)
	F64	Room temperature alarm inhibition time delay (power up)	0(Off)	999	minutes	10	0(Off)	999	minutes	10
	F65	Length of time door is open to trigger alarm	0(Off)	999	minutes	5	0(Off)	999	minutes	5
	F66	Maximum time compressor can be on without reaching the setpoint	0(Off)	999	hours	0(Off)	0(Off)	999	hours	0(Off)
	F67	Trigger for alarm when defrosting is over based on time	0(No)	1(Yes)	-	1(Yes)	0(No)	1(Yes)	-	1(Yes)
F68	Enable buzzer	0(Off)	1(On)	-	0(Off)	0(Off)	1(On)	-	0(Off)	
SENSORS	F69	Intensity of the digital filter on the ambient temperature sensor (S1 sensor) (Rising)	0(Off)	20	seconds	0(Off)	0(Off)	20	seconds	0(Off)
	F70	Intensity of the digital filter on the ambient temperature sensor (S1 sensor) (Descending)	0(Off)	20	seconds	0(Off)	0(Off)	20	seconds	0(Off)
	F71	Displacement of the values from the ambient sensor (S1 sensor)	-20,0	20,0	°C	0,0	-36,0	36,0	°F	0,0
	F72	Displacement of the values from the defrost/suction sensor (S2 sensor)	-20,0	20,0	°C	0,0	-36,0	36,0	°F	0,0
	F73	Displacement of the values from the evaporator inlet sensor (S3 sensor)	-20,0	20,0	°C	0,0	-36,0	36,0	°F	0,0
	F74	Displacement of the values (Offset) for the pressure transducer P1 (Reserved)	0	0	-	0	0	-	-	0
FUNCTIONS	F75	Preferred Indicator	1	7	-	1	1	7	-	1
	F76	Ambient Temperature (S1 sensor) value locked in during defrosting	0	2	-	1	0	2	-	1
	F77	Maximum length of time that the temperature is locked during defrosting	0(Off)	999	minutes	15	0(Off)	999	minutes	15
	F78	Function Lock Mode	0	2	-	0	0	2	-	0
	F79	Function Lock Period	15	60	seconds	15	15	60	seconds	15
	F80	Shutdown of control functions	0(Off)	2	-	0(Off)	0(Off)	2	-	0(Off)
	F81	Address of the instrument on the RS-485 network	1	247	-	1	1	247	-	1

Electronic Expansion Valve configuration functions (displayed if F01 = 717)

	Fun	Description	CELSIUS (°C)				FAHRENHEIT (°F)			
			Min	Max	Unit	Standard	Min	Max	Unit	Standard
ELECTRONIC EXPANSION VALVE	F01	Access code	0	999	-	0	0	999	-	0
	c01	Controller in Driver mode (Reservado)	0	0	-	0	0	0	-	0
	c02	Enable Internal Energy Backup (IEB) (Reservado)	0	0	-	0	0	0	-	0
	c03	Proportional Increase (Kp) (EEV)	1,0	100,0	-	8,0	1,0	100,0	-	8,0
	c04	Integral Time (Ti) (EEV)	0(Off)	500	seconds	120	0(Off)	500	seconds	120
	c05	Derivative Time (dT) (EEV)	0(Off)	500	seconds	0(Off)	0(Off)	500	seconds	0(Off)
	c06	Setpoint - LoSH Protection (Estimated Low superheating)	0,0	F03	°C	2,0	0,0	F03	°F	3,6
	c07	Integral Time (Ti) - Estimated Low Superheating Protection	1	500	seconds	12	1	500	seconds	12
	c08	Setpoint - LOP Protection (Estimated Low evaporation temperature)	-50,0(Off)	c10	°C	-38,0	-58,0(Off)	c10	°F	-36,4
	c09	Integral Time (Ti) LOP Protection (Estimated Low evaporation temperature)	1	500	seconds	30	1	500	seconds	30
	c10	Setpoint - MOP Protection (Estimated High evaporation temperature)	c08	105,0(Off)	°C	-10,0	c08	221,0(Off)	°F	14,0
	c11	Integral Time (Ti) - MOP Protection (Estimated High evaporation temperature)	1	500	seconds	30	1	500	seconds	30
	c12	Time to verify the protection alarms (LoSH, LOP, MOP)	0(Off)	9999	seconds	300	0(Off)	9999	seconds	300
	c13	State of the compressor in the event of protection alarms being triggered (ASHL, ALOP, AMOP)	0	7	-	7	0	7	-	7
	c14	Time until the compressor switches on again after protection alarms are triggered (ASHL, ALOP, AMOP)	0(Off)	999	minutes	2	0(Off)	999	minutes	2
	c15	Total number of steps for the valve	20	550	-	500	20	550	-	500
	c16	Operating Speed (steps per second)	25	90	-	30	25	90	-	30
	c17	Minimum Valve Opening	0,0	c18	%	3,0	0,0	c18	%	3,0
	c18	Maximum Valve Opening	c17	100,0	%	100,0	c17	100,0	%	100,0
	c19	Initial Valve Opening	c17	c18	%	25,0	c17	c18	%	25,0
	c20	Time valve is used after initial opening	0(Off)	300	seconds	60	0(Off)	300	seconds	60
	c21	Time valve is used after initial opening after defrosting	0(Off)	3000	seconds	120	1	3000	seconds	120
	c22	Valve opening during hot gas defrost	c17	c18	%	3,0	c17	c18	%	3,0

Variable Speed Compressor Setup Functions (displayed if $[F01] = 718$)

Fun	Description	CELSIUS (°C)				FAHRENHEIT (°F)			
		Min	Max	Unit	Standard	Min	Max	Unit	Standard
[F01]	Access Code	0	999	-	0	0	999	-	0
[CP01]	Compressor type	1	2	-	2	1	2	-	2
[CP02]	Proportional gain (Kp) (VCC)	1,0	100,0	-	2,0	1,0	100,0	-	2,0
[CP03]	Integral time (Ti) (VCC)	1	500	seconds	100	1	500	seconds	100
[CP04]	Derivative time (Td) (VCC)	0(Off)	500	seconds	0(Off)	0(Off)	500	seconds	0(Off)
[CP05]	Minimum frequency for variable compressor PID control	30	[CP06]	Hz	60	30	[CP06]	Hz	60
[CP06]	Maximum frequency for variable compressor PID control	[CP05]	[CP07]	Hz	120	[CP05]	[CP07]	Hz	120
[CP07]	Maximum frequency for variable compressor operation	30	300	Hz	150	30	300	Hz	150
[CP08]	Variable compressor stop frequency (switch-off)	0	50	Hz	30	0	50	Hz	30
[CP09]	Variable compressor frequency during a hot gas defrost	[CP05]	[CP07]	Hz	120	[CP05]	[CP07]	Hz	120
[CP10]	Variable compressor frequency in the event of an error in sensor S1 (room sensor)	[CP05]	[CP06]	Hz	100	[CP05]	[CP06]	Hz	100
[CP11]	Variable compressor smooth start frequency	[CP05]	[CP06]	Hz	60	[CP05]	[CP06]	Hz	60
[CP12]	Variable compressor smooth start time	1	999	seconds	60	1	999	seconds	60
[CP13]	Variable compressor time on after reaching the setpoint	0(Off)	999(On)	minutes	30	0(Off)	999(On)	minutes	30
[CP14]	Variable compressor time below limit frequency [CP16] for lubrication	10(Off)	1440	minutes	360	10(Off)	1440	minutes	360
[CP15]	Variable compressor time on frequency [CP07] for compressor lubrication	10	999	segundos	30	10	999	segundos	30
[CP16]	Minimum frequency for variable compressor lubrication control	[CP05]	[CP06]	Hz	80	[CP05]	[CP06]	Hz	80
[CP17]	Maximum time for the variable compressor turned on to maximum frequency	0(Off)	999	minutes	600	0(Off)	9999	minutes	600
[CP18]	Low temperature limit (differential for the temperature setpoint)	1,0 (Off)	99,9	°C	1,2	1,8 (Off)	179,8	°F	2,1
[CP19]	High temperature limit (differential for the temperature setpoint)	1,0 (Off)	99,9	°C	6,0	1,8 (Off)	179,8	°F	10,8

9.5.1 Description of the Parameters

F01 - Access Code:

This is required to change the settings of the parameters. This code does not need to be entered to view the adjusted parameters.

Allows you to enter the access codes provided:

[123] - Enables you to change the table parameters;

[231] - Enables you to configure the units of measurement for temperature and pressure;

[111] - Enables you to change the settings for the parameters of the electronic expansion valve.

[118] - Enables you to change the settings for the parameters of the variable compressor;

F02 - Type of application (Reserved):

Parameter not available in this model.

F03 - Estimated Superheating Setpoint:

This is the reference value for control of superheating.

Superheating indicates how much vapor is over the saturation temperature (boiling point) at a given pressure.

A temperature sensor is required at the evaporator inlet and another temperature sensor in the suction line.

Superheating = Suction temperature - saturated vapor temperature (fluid curve).

F04 - Liquid refrigerant (Reserved):

Parameter not available in this model.

F05 - Lower Pressure Limit of the P1 transducer (Pressure at 4mA) (Reserved):

Parameter not available in this model.

F06 - Upper Pressure Limit of the P1 transducer (Pressure at 20mA) (Reserved):

Parameter not available in this model.

F07 - Desired Temperature - Normal Setpoint:

It is the control temperature of the normal operating mode. When the temperature of the S1 sensor (ambient) is lower than the value set for this function the compressor will be turned off.

F08 - Desired Temperature - Economic Setpoint:

It is the control temperature when the economic operating mode is on. When the temperature of the S1 sensor (ambient) is lower than the value set for this function the compressor will be turned off.

F09 - Minimum setpoint allowed by the end user:

F10 - Maximum setpoint allowed by the end user:

Limits set in order to avoid excessively high or low temperatures being accidentally set for the temperature setpoint, which could lead to high energy consumption by keeping the system on continuously.

F11 - Control differential - Normal setpoint (hysteresis):

F12 - Control differential - Economic setpoint (hysteresis)

This is the temperature difference between switching off and restarting refrigeration in economic operating mode.

F13 - Pump Down Pressure or evaporator pressure (EPR) setpoint (Reserved):

Parameter not available in this model.

F14 - Maximum Time for Pump Down (Reserved):

Parameter not available in this model.

F15 - Time for Economic Mode to begin (Monday to Friday):

Time when the economic setpoint [SP-E] will be activated on working days.

This function can be turned off by setting it to the maximum value [FFF].

F16 - Time for Economic Mode to begin (Saturday)

Time when the economic setpoint [SP-E] will be activated on Saturdays.

This function can be turned off by setting it to the maximum value [FFF].

F17 - Time for Economic Mode to begin (Sunday):

Time when the economic setpoint [SP-E] will be activated on Sundays.

This function can be turned off by setting it to the maximum value [FFF].

F18 - Maximum time in economic mode:

Allows you to set the maximum length of time economy mode will operate for. After this time, the setpoint returns to economy mode in normal operation. If this is set to [FFF] this time will be ignored.

F19 - Fast Freezing Temperature Limit:

This is the minimum temperature that the instrument can reach during the Fast Freezing process.

F20 - Maximum Fast Freezing time:

This is the duration of the Fast Freezing process.

F21 - Minimum time for compressor to be on:

This is the minimum amount of time the compressor will be on, i.e. The period of time between the last section and the next time it is stopped. This helps to avoid power surges from the electricity grid.

F22 - Minimum time for compressor to be off:

This is the minimum amount of time the compressor will be off, i.e. The period of time between the last time it stops and the next section. This helps to relieve the discharge pressure and increases the working life of the compressor.

F23 - Length of time the compressor is on, if there is an error with the ambient S1 sensor:

F24 - Length of time the compressor is off, if there is an error with the ambient S1 sensor:

If the ambient sensor (S1 sensor) is disconnected or goes out of the measurement range, the compressor will switch on or off according to the parameters set in these functions.

F25 - Control Action if there is an error in the estimated superheating sensors:

[FFF] - Control turned off. Keeps the electronic valve closed and all control outputs off, except the AUX output if it is configured as an alarm output.

[111] - Keeps the valve set to the position configured in ([19] - Initial Valve Opening) and all control outputs operate normally.

F26 - Delay time when powering up the controller:

When the instrument is turned on, it can remain disabled for a while, delaying the start of the process. During this time, it only works as a temperature / pressure gauge. Helps to avoid high demands for power, when power returns after a power cut, where several pieces of equipment are all on the same connection. Therefore, you can set different times for each device. This delay can relate to the compressor or defrosting (where defrosting is part of the sequence)

F27 - Defrost type (0=coils / 1 = hot gas / 2 = natural):

[0] - Electrical Defrosting (using coils), which only applies to the defrost outlet.

[1] - Hot Gas Defrosting, which only applies to the compressor and defrosting outlets.

[2] - Natural defrosting, which only applies to the fan outlet.

F28 - Condition for starting defrosting:

[FFF] - No automatic defrosting, only manual defrosting;

[1] - Set time to start defrosting;

[2] - Set temperature to start defrosting;

[3] - Set temperature difference (S1-S2) to start defrosting;

[4] - Set temperature and temperature difference (S1-S2) to start defrosting;

[5] - Schedule Defrosting.

F29 - Interval between defrosting periods if F28=1 or the Maximum time without defrosting if F28=2, 3 or 4:

It determines how often and after how long defrosting take place, based on the time of the last defrosting. If the controller is configured to defrost according to temperature ([F28] = 2, 3 or 4), this time acts as a level of safety in situations in which the evaporator temperature (S2 sensor) does not reach the values programmed in [F31] or [F32]. This function determines the maximum time that the controller will wait before carrying out defrosting.

F30 - Additional time to the end of the first refrigeration cycle if [F28] = 1:

This is to set a longer period of time for the first refrigeration cycle. Where there are setups with several pieces of equipment, you can avoid high demand peaks by ensuring that defrosting takes place at different times by assigning different values to this function.

F31 - Temperature of the evaporator (S2 sensor) in order to begin defrosting if F28=2 or 4.

When the temperature of the evaporator (S2 sensor) reaches a value using this function, the controller will wait for the length of time before beginning defrosting.

F32 - Temperature Difference in order to start defrosting (S1-S2) if F28=3 or 4.

When the difference between the temperature of the ambient sensor (S1 sensor) and the temperature of the evaporator (S2 sensor) reaches a value using this function, the controller will wait for the length of time before beginning defrosting.

F33 - Time to confirm to start the pre-defrost setting if F28=2, 3 or 4

If the controller is configured to perform defrosting by temperature or temperature difference, at the moment the temperature of sensor S2 ($[F28] = 2$ or 4) or the difference (S1 - S2) ($[F28] = 3$) reaches the configured value, the confirmation time starts counting to start pre-defrosting. During this step, if the temperature of sensor S2 remains low or the difference (S1 - S2) remains high, pre-defrosting starts. Otherwise, the system continues in the cooling stage.

F34 - Defrost when the controller is powered on

This enables a defrosting to be conducted when the controller is powered on. For example, when the electricity returns after a power cut.

F35 - Smooth Defrost if F27=0:

Smooth Defrost mode provides a smoother defrosting, saving energy and preventing the ambient temperature from rising as much as in a standard defrost. In this mode, the defrost output remains on as long as the evaporator temperature (S2 sensor) is less than 2°C (35.6°F) and, after passing that temperature, the output remains on for the percentage of time configured in this function, within a 2-minute period.

F36 - Enable Tray Defrost:

- $[FF]$ - Deactivates Tray Defrosting;
- $[1]$ - Defrosting the tray using the FAN outlet;
- $[2]$ - Defrosting the tray using the AUX outlet;

The chosen output acts as a second defrosting output. This output is activated during the pre-defrost, defrost and drain periods. The functionality related to the control of this output (FAN or AUX) will be disregarded.

F37 - Number of Defrostings per day (Monday to Friday) if F28=5

Defrosting is set to take place at equal intervals according to the number programmed per day, always taking preferred times into account. It can be adjusted using values of 1, 2, 3, 4, 6, 8 or 12.

This function is to program this for Monday to Friday.

F38 - Time to start Defrost (Monday to Friday) if F28=5

Enables the preferred start time of one of the daily defrost cycles to be adjusted.

This function is to program this for Monday to Friday.

F39 - Number of Defrostings per day (Saturday) if F28=5

Defrosting is set to take place at equal intervals according to the number programmed per day, always taking preferred times into account. It can be adjusted using values of 1, 2, 3, 4, 6, 8 or 12. This functions is to program this for Saturday

F40 - Time to start Defrost (Saturday) if F28 = 5:

Enables the preferred start time of one of the daily defrost cycles to be adjusted. This function is to program this for Saturday.

F41 - Number of Defrostings per day (Sunday) if F28=5:

Defrosting is set to take place at equal intervals according to the number programmed per day, always taking preferred times into account. It can be adjusted using values of 1, 2, 3, 4, 6, 8 or 12. This function is to program this for Sunday.

F42 - Time to start Defrost (Sunday) if F28=5

Enables the preferred start time of one of the daily defrost cycles to be adjusted. This function is to program this for Sunday.

F43 - Length of pre-defrost (collecting in gas):

When the defrost starts, the controller will only use the fan during this time, in order to take advantage of the residual energy of the gas.

F44 - Temperature of the Evaporator (S2 sensor) to finish the defrost:

If the temperature in the evaporator (sensor S2) reaches the set value, the defrost cycle will be halted, i.e. Temperature controlled. This way it improves the defrosting process.

F45 - Temperature of the Ambient Sensor (S1 sensor) to finish the defrost:

If the ambient temperature (sensor S1) reaches the set value, the defrost cycle will be halted, i.e. Temperature controlled.

F46 - Maximum time on defrost (for safety):

This function adjusts the maximum duration of a defrost cycle. If the defrosting is not complete, during this period, according to the temperature, a dot will begin flashing in the lower right corner of the display (if it's enabled in $[F57]$), indicating that the time set for the defrost has ended by the required temperature has not been reached. This can happen when the temperature set is too high, the time limit is insufficient, the S2 sensor is disconnected or it isn't in contact with the evaporator.

F47 - Draining time (from water collected from defrosting):

Time required for removing excess water, i.e. for the last drops of water to drain from the evaporator. During this period, all outputs remain switched off. This function can be turned off by setting it to the minimum value $[FF]$.

F48 - Fan operation mode:

- $[0]$ - Automatic according to time: the fan will be on when the compressor is on. When the compressor is off, the fan will oscillate according to the times set in $[F49]$ and $[F50]$;
- $[1]$ - Automatic according to temperature: When the compressor is switched on, the fan stays on. With the compressor off, the fan turns on when the temperature is higher than the setpoint + 60% of the hysteresis and turns off when the temperature is lower than the setpoint + 20% of the hysteresis;
- $[2]$ - Continuous: the fan is always on;
- $[3]$ - Dependent: the fan operates together with the compressor;
- $[4]$ - For a period of time after the compressor is turned off: after turning off the compressor, the fan will remain on for the time set in $[F49]$.

Note1: Modes 0 and 1 will only switch the fan on if the temperature of the S2 sensor is lower than the temperature of the S1 sensor.

Note2: Mode 1 will activate the fan only if the temperature of sensor S2 is lower than the configured setpoint.

F49 - Time fan is on if F48=0 or 4

This is how long the fan is on for.

F50 - Time fan is turned off if F48=0 (automatic timed mode):

This is how long the fan is off for.

F51 - Length of time door is open until fan is turned off F55=1 or 2:

This is the length of time that the fan will continue to run after the door is opened. If you set a minimum value of $[FF]$, the fan will not switch off if the door is opened. If you set a value of $[0]$, the fan will switch off immediately if the door is opened.

F52 - Fan cut off due to high temperature in the evaporator (S2 sensor):

This is intended to disconnect the evaporator fan when the ambient temperature is not within the design range for the refrigeration device, avoiding high temperatures and suction pressures that could damage the compressor. If the evaporator temperature exceeds the set value, the fan is turned off and will be restarted at a fixed hysteresis of 2°C (3.6°F). This is a useful function to use when, for example, a refrigerator is used that has been idle for days or when restocking units or counters with products.

F53 - Temperature in the evaporator to switch the fan back on after draining:

After drainage is complete, it starts a fan-delay cycle. The compressor will start up immediately, because the temperature in the evaporator is high, but the fan will only start after the temperature in the evaporator falls below the set value. This function is used to remove the heat in the evaporator after a defrost cycle, to ensure it is not opened up immediately to the ambient temperature.

F54 - Maximum length of time until the fan is switched back on after drainage (fan-delay):

For safety, if the temperature in the evaporator does not reach the value set by function $[F53]$ or the S2 sensor is disconnected, the fan will only come on after the time set for this function has expired.

F55 - Function mode of the digital input:

- $[FF]$ - Digital Input deactivated;
- $[1]$ - NO Contact: Door Sensor;
- $[2]$ - NC Contact: Door Sensor;
- $[3]$ - NO Contact: External Alarm;
- $[4]$ - NC Contact: External Alarm;
- $[5]$ - NO Contact: Switch off the Control System;
- $[6]$ - NC Contact: Switch off the Control System;
- $[7]$ - NO Pulsator: Economic Mode;
- $[8]$ - NC Pulsator: Economic Mode;
- $[9]$ - NO Pulsator: Fast Freezing;
- $[10]$ - NC Pulsator: Fast Freezing;
- $[11]$ - NO Pulsator: Defrosting;
- $[12]$ - NC Pulsator: Defrosting.

Obs: In options 5 and 6, the Sitrad supervisory system has priority over the digital input. Thus, if Sitrad sends a command to turn on / off the control functions, the digital input is temporarily disabled and a transition in its state will be necessary to enable it again.

F56 - Length of time door is open for instant defrost if F55=1 or 2:

If the door is kept open for a period longer than that defined in this function, instant defrosting will take place, as long as the temperature in the evaporator (S2 sensor) is less than $[F44]$ and the ambient temperature (S1 sensor) is less than $[F45]$.

F57 - Length of time door is open until fan and compressor are turned off F55=1 or 2:

For safety, if the door remains open longer than the time set here, both the compressor and fan will be switched off.

F58 - Length of time door is closed until economic mode is activated if F55= 1 or 2:

With the door closed, this parameter defines how long until economic mode is activated. Setpoint is switched to the economic setpoint.

F59 - Length of time door is closed until light is switched off if F55= 1 or 2 and F60=1:

With the door closed, this parameter defines how long it will be until the lamp is turned off. Helps save electricity. With this function set to the minimum value $[FF]$, all functions related to lamp activation are ignored and the output remains off.

F60 - AUX output mode:

- $[0]$ - Output switched off;
- $[1]$ - Light switching;
- $[2]$ - Alarm switching.

Note: If it is set up as an alarm switch, the AUX output will be turned on in the event of the following alarms: open door, high / low ambient temperature, compressor on without reaching the setpoint, external alarm (digital input), estimated low superheating, MOP, LOP, Internal Energy Backup error or error in the electronic expansion valve.

F61 - Low ambient temperature alarm (S1 sensor):

This is the ambient temperature (S1), below which the instrument will trigger the low temperature alarm. The differential for switching off the alarm is set in 0.1 °C / 0.1 °F. During the Fast Freezing operation, the low temperature alarm is deactivated. When this process is over it is reactivated when the temperature is no longer within the range of the alarm.

F62 - High ambient temperature alarm (S1 sensor):

This is the ambient temperature (S1), above which the instrument will trigger the temperature alarm. The differential for the alarm to switch off is fixed at 0.1 °C / 0.1 °F. This alarm takes into account the temperature shown on the display and is therefore determined by the temperature reading locked during the defrost cycle $[F76]$.

F63 - Time to confirm the alarm by room temperature (S1):

This is the length of time, during which the ambient temperature alarm (low or high) will be inactive, even if the conditions exist to trigger it.

F64 - Room temperature alarm inhibition time delay (power up):

During this time the alarm remains off while waiting for the system to go back to an operating mode. The (low or high) ambient temperature alarms are enabled after this time has elapsed or the setpoint temperature has been reached.

F65 - Length of time door is open to trigger alarm:

When the door is opened, the message $[PE]$ appears on the display and the door open timer starts. If this time is longer than the time that is set for this function, the alarm will be triggered

F66 - Maximum time compressor can be on without reaching the setpoint:

The alarm is triggered if the compressor remains on without reaching the setpoint, for a longer time than the length specified in this function.

F67 - Trigger for alarm when defrosting is over based on time:

When the defrost cycle has been running for the length of time set, but has not reached the temperature set, the user is notified via a flashing dot in the lower right corner of the display ($[]$).

F68 - Enable Buzzer:

Enables or disables the internal buzzer to sound alarms.

F69-Intensity of the digital filter on the ambient temperature sensor (S1 sensor) (Rising):
F70-Intensity of the digital filter on the ambient temperature sensor (S1 sensor) (Descending):
The value set by these functions represents the time (in seconds) in which the temperature may vary 0.1°C / 0.1 °F either up or down.

Note: A typical use for this type of filter is in freezers for ice cream and frozen foods. When the door is opened, a quantity of hot air will fall directly on the sensor, causing a rapid rise in the temperature reading and, often, activating the compressor unnecessarily.

F71-Displacement of the values from the ambient sensor (S1 sensor):
F72-Displacement of the values from the defrost/suction sensor (S2 sensor)
F73-Displacement of the values from the evaporator inlet sensor (S3 sensor)
Allows to compensate for any deviations in the sensor/transducer reading, resulting from changing the sensor or changing the cable length.

F74-Displacement of the values (Offset) for the pressure transducer P1:
Parameter not available in this model.

F75-Preferred Indicator:
Sets a preference for what is shown on the display:
 1 : Temperature from the ambient sensor S1;
 2 : Temperature of the defrost/suction sensor S2;
 3 : Temperature from the evaporator inlet sensor S3;
 4 : Variable compressor frequency;
 5 : Superheating Temperature;
 6 : Percentage that the Electronic Expansion Valve has been opened;
 7 : Current Setpoint Value (normal or economic).

F76-Ambient Temperature (S1 sensor) value locked in during defrosting:
 0 : Temperature Reading from the ambient sensor S1
 1 : Reading locked in - last temperature before defrosting
 2 : Display "dEEF" "
This function is intended to prevent the display reflecting an increase in the ambient temperature due to defrosting.

F77-Maximum length of time that the temperature is locked during defrosting:
During a defrost cycle, either the last temperature measured during the refrigeration cycle or the message "dEEF" will be kept on the display. The display will be released when the temperature shown is reached again or the time set for this function has been exceeded, after the start of the next refrigeration cycle (whichever comes first). If set to the value "dFFF", the temperature display will be frozen only while defrosting.

F78-Function Lock Mode:
Enables and configures the Function Lock (see item 9.3.10).
 0 : Function Lock can't be enabled
 1 : Partial lock can be enabled, whereby the control functions are locked but the setpoint can still be adjusted.
 2 : Functions can be completely locked.

F79-Function Lock Period:
Sets the time in seconds after the command that the functions will be locked.
 15 - 60 Time in seconds after the command that the functions will be locked.

F80-Turns Off Control Functions:
Allows the control functions to be turned off (see item 9.3.11).
 dFFF : Does not allow the control functions to be turned off.
 1 : Only allows control functions to be turned on or off if the functions are unlocked.
 2 : Allows control functions to be turned on or off even if the functions are locked.

F81-Address of the instrument on the RS-485 network:
Address of the instrument on the RS-485 network that enables it to communicate with the Sitrad software.
Note: You may not have any device on the network with the same address.

Electronic Expansion Valve configuration functions 0 1 to 2 2 (displayed if F 0 1 = 717)

C01-Controller is in Driver mode (Reserved):
Parameter not available in this model.

C02-Enable Internal Energy Backup (IEB) (Reserved):
Parameter not available in this model.

C03-Proportional Increase (Kp) (EEV):
Determines the proportional increase based on the PID Control Algorithm.

C04-Integral Time (Ti) (EEV):
Determines the Integral Time based on the PID Control Algorithm.

C05-Derivative Time (dT) (EEV):
Determines the Derivative Time based on the PID Control Algorithm.

C06-Setpoint - LoSH Protection (Estimated low superheating):
When the estimated superheating temperature is below this value, the low superheat alarm will gradually close the electronic expansion valve (EEV).
Note: Hysteresis for the parameter is set 1°C (1,8°F).

C07-Integral Time (Ti) - Low Superheating Protection:
Time required to correct the difference between the recorded superheating and its setpoint value, when the stabilized superheating temperature is below the LoSH protection setpoint (value defined by c 0 5).

C08-Setpoint - LOP Protection (Estimated low evaporation temperature):
When the estimated evaporation temperature is below this value, the electronic expansion valve (EEV) will gradually open to increase the evaporation temperature of the system. This process will continue until the evaporation temperature reaches the value set by this function.

Note: The estimated evaporation temperature is obtained through sensor S3 - Inlet sensor of the evaporator.

C09-Integral Time (Ti) - LOP Protection (Estimated low evaporation temperature):
Time required to correct the difference between the recorded superheating and its setpoint, as a constant value, when the stabilized estimated evaporation temperature is below the LOP protection setpoint.

C10-Setpoint - MOP Protection (Estimated low evaporation temperature):
When the estimated evaporation temperature is above the value set for this function, the controller will gradually close the electronic expansion valve (EEV) to keep the evaporation temperature below the set value. This is intended to ensure that when superheating is very low, liquid does not flow back into the compressor.

Note: The estimated evaporation temperature is obtained through sensor S3 - Inlet sensor of the evaporator.

Note: Hysteresis for the parameter c 0 8 and c 1 0 is set 2°C (3,6°F).

C11-Integral Time (Ti) - MOP Protection (Estimated low evaporation temperature):
Time required to correct the difference between the recorded superheating and its setpoint, as a constant value, when the stabilized estimated evaporation temperature is above the MOP protection setpoint.

C12-Time for checking the protection alarms (LoSH, LOP, MOP):
This is the length of time, during which the protection alarm (LoSH, LOP, MOP) will be inactive, even if the conditions exist to trigger it.

C13-State of the Compressor in the event of protection alarms being triggered (ASHL, ALOP, AMOP):
 0 - Compressor will not switch off when ASHL, ALOP or AMOP alarms are triggered;
 1 - Compressor will switch off when ASHL alarm is triggered;
 2 - Compressor will switch off when ASHL or ALOP alarm is triggered;
 3 - Compressor will switch off when ASHL or AMOP alarm is triggered;
 4 - Compressor will switch off when ALOP alarm is triggered;
 5 - Compressor will switch off when ALOP or AMOP alarm is triggered;
 6 - Compressor will switch off when AMOP alarm is triggered;
 7 - Compressor will switch off when either the ASHL, ALOP or AMOP alarms is triggered.

C14-Time until the compressor switches on again after protection alarms are triggered (ASHL, ALOP, AMOP):
This is the length of time that the compressor remains off after an alarm is triggered, according to the defined option c 1 3.

C15-Total number of steps for the valve:
This functions sets the specific number of steps that the electronic expansion valve (EEV) will use.

C16-Operating Speed (steps per second):
This functions sets the operating speed according to the specifications of the electronic expansion valve (EEV).

C17-Minimum Valve Opening:
This is the smallest percentage that the electronic expansion valve will open.

C18-Maximum Valve Opening:
This is the largest percentage that the electronic expansion valve will open.

C19-Initial Valve Opening:
This function defines the percentage that the electronic expansion valve will open when control begins.

C20-Time valve is used after initial opening:
This is the maximum time that the electronic expansion valve will be opened as set in the c 1 9 function.

C21-Time valve is used after initial opening after defrosting:
This is the maximum time that the electronic expansion valve will be opened as set in the c 1 9 function, after a defrost cycle.

C22-Valve opening during hot gas defrost:
In this function, the percentage value of opening of the electronic expansion valve during the hot gas defrosting process is defined.

Variable compressor setting functions c P 0 1 to c P 1 9 (displayed if F 0 1 = 718) variable compressor control settings differ by make and model of variable compressor used. Consult the technical manual of the compressor.

In traditional refrigeration applications, the demand for running the compressor at full load is rare and restricted to a few days a year. Controlling the operating frequency of a variable capacity compressor adapts its use to actual demand. In this way, the compressor runs at a low speed most of the time, minimizing energy consumption.

The operating frequency is proportional to the cooling capacity defined in parameters c P 0 5 and c P 0 6. Parameter c P 0 7 defines the maximum operating frequency of the compressor and is used in situations where you want to rapidly reduce the temperature of the controlled environment.

It is possible to keep the compressor operating continuously, keeping the temperature of the controlled environment stable and reducing the number of compressor starts, resulting in energy savings. To obtain this characteristic, must be programmed the parameter c P 1 3 - Time for the variable compressor to be turned on after reaching the setpoint.

CP01-Compressor type:
 1 - On-Off type fixed speed compressor (relay output).
 2 - Variable Capacity Compressor-VCC with output frequency from 0 to 300Hz.
Note 1: If c P 0 7 = 1, parameters c P 0 2 to c P 1 9 are ignored and traditional control is carried out through the compressor relay.
Note 2: If c P 0 7 = 2, the relay compressor output is on while the variable compressor is on (optional use as a solenoid).

CP02-Proportional gain (Kp) (VCC):
Determines the proportional gain of the PID control algorithm.

CP03-Integral time (Ti) (VCC):
Determines the integral time of the PID control algorithm.

CP04-Derivative time (Td) (VCC):
Determines the derivative time of the PID control algorithm.

CP05 - Minimum frequency for variable compressor PID control:
Defines the minimum working frequency of the variable compressor in automatic control mode (PID algorithm).

Note: check the variable compressor technical manual.

CP06 - Maximum frequency for variable compressor PID control:
Defines the maximum working frequency of the variable compressor in automatic control mode (PID algorithm).

Note: check the variable compressor technical manual.

CP07 - Maximum operating frequency of the variable compressor:
Defines the maximum operating frequency of the compressor. This frequency is used when it is necessary to quickly cool the controlled environment, e.g., high room temperature, Fast Freezing process or after a defrost cycle.

Note: check the variable compressor technical manual.

CP08 - Compressor stop frequency (switch-off):
Defines the output frequency to inform the compressor to stop. This frequency is lower than the minimum working frequency.

Note: check the variable compressor technical manual.

CP09 - Variable compressor frequency during hot gas defrost:
Defines the variable compressor frequency during the hot gas defrost process

CP10 - Variable compressor frequency in case of error in sensor S1 (room temperature):
Defines the frequency of the variable compressor if an error is detected in temperature sensor S1 (ambient). This parameter works together with and .

CP11 - Variable compressor soft start frequency:
When switching on the variable compressor, it is kept at a low speed for a few seconds, as set in . The purpose of this feature is to improve compressor lubrication.

CP12 - Variable compressor soft start time:
Time that the variable compressor will be on at the soft start frequency. The purpose of this feature is to improve compressor lubrication.

CP13 - Variable compressor on time after reaching the setpoint:
After reaching the temperature setpoint, it is possible to keep the compressor on at a speed calculated by the PID control algorithm. The objective is to avoid successive starts of the compressor, obtaining a reduction in energy consumption (energy efficiency) and low oscillation of the room temperature (sensor S1). If set to , the variable compressor is turned off immediately after reaching the temperature setpoint. If set to , the compressor will always be on. If the temperature reaches the low temperature limit the compressor is turned off and will turn on again respecting the setpoint and control hysteresis.

CP14 - Variable compressor time below CP16 limit frequency for lubrication:
Time in which the variable compressor must remain on with a frequency below the limit configured in to operate at the frequency configured in for the time configured in . This process of periodic acceleration of the control frequency promotes the lubrication of the variable compressor through the migration of the lubricating oil.

CP15 - Variable compressor time on frequency CP07 for compressor lubrication:
Time that the variable compressor will stay on at the frequency defined in for compressor lubrication.

CP16 - Minimum frequency for variable compressor lubrication control:
Limit frequency for the instrument to use the variable compressor lubrication process.

CP17 - Maximum time of variable compressor on at maximum frequency:
Maximum time for the variable compressor at maximum frequency. This parameter works together with .

CP18 - Low temperature limit (differential for temperature setpoint):
Sets the low temperature limit for switching off the variable compressor. In this parameter, the differential for the setpoint is adjusted.
Example: Setpoint = and = . In this case, the temperature limit for turning off the compressor will be (- .

CP19 - High temperature limit (differential for temperature setpoint):
Sets the high temperature limit for driving the variable compressor at its maximum operating frequency. The purpose of this parameter is to quickly lower the ambient temperature controller. In this parameter, the differential for the setpoint is adjusted. The hysteresis for this parameter is fixed at 1.0°C (1.8°F).
Example: Setpoint = and = .
In this case, the compressor will operate at maximum speed when the temperature is above (+), and will return to normal speed operation (between and when the temperature is below (+ - .

10. PID CONTROLLER

The PID controller is made up of a combination of three control actions: Proportional action (P), Integral action (I) and Derivative action (D). Each action receives a weighting (adjustable via parameters) which represents a gain or adjustment time. This enables the PID to perform better when controlling the process. Any control action is limited by the quality and capacity of the existing actuators in the process.

P - Proportional gain (Kp) - The use of proportional action in a control system enables the difference (error) between the desired output (reference, setpoint) and the current value of the process, to be reduced. The proportional gain speeds up process's response, however, the increased gains can result in control oscillating.

I - Integral time (Ti) - The integral action has an energy storage function, which allows it to remove the error between the reference and the output. It accumulates the error at a "Ti" rate, and attempts to reduce it to zero. Low Ti values can cause the control to oscillate, however, long Ti times tend to slow down the process. Integral action must not be used on its own.

D - Derivative time (Td) - The use of derivative action enables the process's response time to be increased and reduces oscillation, as it tries to anticipate the process's behavior. Low Td values tend to reduce oscillation

SUMMARY TABLE - GENERAL GUIDANCE*

PID PARAMETER	OVERSHOOT (peak)	STABILIZATION TIME (delay in stabilizing the controller)	ERROR (The difference between the setpoint and the sensor)
Increase KP**	Increase	Little Effect	Reduce
Reduce Ti	Increase	Increase	Null error
Increase Td	Reduce	Reduce	No effect



Note: Change the parameters individually, check the response and then modify another parameter. Proceed with caution, use *Sitrad Pro* to monitor the behavior of the process, analyze and modify the control parameters.

* This guide is widely applied in the technical literature on PID controllers, however processes with latency in their response may differ from the indication in the table. The technician responsible for the process must correct small deviations manually.

** In specific applications, the behavior can be opposite to that indicated.

11. WARNINGS / ALARMS / ERRORS

11.1 Warnings

<input type="text" value="OPEN"/>	Door open
<input type="text" value="Fr"/>	Variable compressor frequency
<input type="text" value="SH"/>	Superheating Temperature
<input type="text" value="UEE"/>	Percentage that the Electronic Expansion Valve has been opened
<input type="text" value="t-1"/>	Temperature sensor 1
<input type="text" value="t-2"/>	Temperature sensor 2
<input type="text" value="t-3"/>	Temperature sensor 3
<input type="text" value="ECO"/>	Operating on the Economic Setpoint
<input type="text" value="CLD"/>	Adjust / View the date and time
<input type="text" value="DEFr"/>	Temperature locked on defrosting cycle
<input type="text" value=""/>	Indicates that the final defrosting temperature has not been reached
<input type="text" value="Info"/>	Information unavailable - check the parameter. Preferred indicator (see parameter <input type="text" value="F75"/>)
 Flashing Led	Tray is defrosting - pre-defrost and draining stages
 Flashing Led	Fast Freezing Mode Indicated
<input type="text" value="MAN"/>	The Electronic Expansion Valve is operating in Manual Mode
<input type="text" value="LOC"/> <input type="text" value="On"/>	Function Lock
<input type="text" value="LOC"/> <input type="text" value="OFF"/>	Functions Unlocked
<input type="text" value="OFF"/>	Control functions off

11.2 Alarms

ROP	Open door alarm
Rthi	High ambient temperature alarm
RtLo	Low ambient temperature alarm
ALrc	Alarm because the compressor is on and has not reached the setpoint
inib	Audible alarm deactivated
ALrE	Digital input alarm (external alarm)
RSHL	Low superheating alarm
RLOP	Low evaporation temperature alarm
RROP	High evaporation temperature alarm

11.3 Errors

Err1	Error in temperature sensor 1
Err2	Error in temperature sensor 2
Err3	Error in temperature sensor 3
ErrSH	Error in the superheating calculation
ECLD	Clock not set
ECLAL	Contact Full Gauge
PPPP	Reset function values
ErrUE	Error with the Electronic Expansion Valve. To clear the error it is necessary to switch off and switch on the controller to restart the unit. (* Also please check coil valve if wiring connections are properly connected or if are connected).

12. GLOSSARY

- °C: Temperature in degrees Celsius.
- °F: Temperature in degrees Fahrenheit
- Defr (defrost): Defrosting
- LOC: Locked.
- No: No.
- OFF: Turned Off / Deactivated
- ON: Turned On / Activated.
- Refr: Refrigeration.
- SET: set or configure.
- EEV: Electronic Expansion Valve

13. CONNECTING CONTROLLERS, RS-485 SERIAL INTERFACE AND COMPUTER

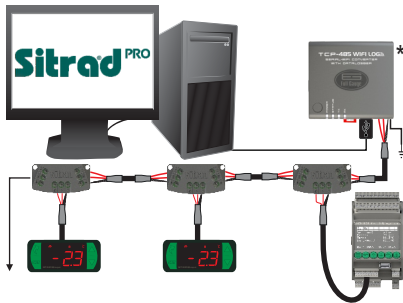

***INTERFACE SERIAL RS-485**
Device used to establish the connection of Full Gauge Controls instruments with Sitrad®.

Full Gauge offers different interface options, including technologies such as USB, Ethernet, Wifi, among others.
For more information, consult Full Gauge Controls.

Sold separately.

MODBUS PROTOCOL
The controller allows you to configure the RS-485 communication port for the MODBUS-RTU protocol. For more information about the implemented commands and the registration table, contact Full Gauge Controls.



CONNECTION BLOCK

It is used to connect more than one controller to the Interface. The wire connections must be made as follows: Terminal A of the controller connect to terminal A of the connection block, which in turn, must be connected to terminal A of the Interface. Repeat the procedure for terminals B and $\frac{1}{2}$, being $\frac{1}{2}$ the cable screen.

14. OPTIONAL ITEMS - SOLD SEPARATELY

EasyProg - version 6 or higher

This is an accessory, whose main function is to store the parameters of the controllers. You can load new parameters from a controller at any time, and download them to a production line (from the same controller), for example.

It has three types of connection for loading or clearing parameters:

- **Serial RS-485:** Connect it to the controller using the RS-485 network (only controllers that can access RS-485).

- **USB:** If connected to the computer by a USB port, it can use Sitrad's Program Editor.

- **Serial TTL:** The controller can connect directly to

EasyProg by a Serial TTL connection.

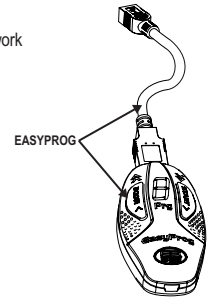

IMPORTANT

IN ORDER TO COMMUNICATE WITH EASYPROG, THE EQUIPMENT MUST NOT BE LINKED TO SITRAD SOFTWARE.

Extended Panel

Full Gauge Controls extended panel allows controllers to be installed in Evolution and Ri lines, whose maximum size is 76x34x77mm (the opening must measure 71x29mm for the extended panel to be installed), as the opening does not need to be precise for the device to be properly installed. The panel has space to be branded with the company logo and contact information, and it has 10A switches (250 V ac) that can be used for switching on internal lighting, ventilation or fan systems.

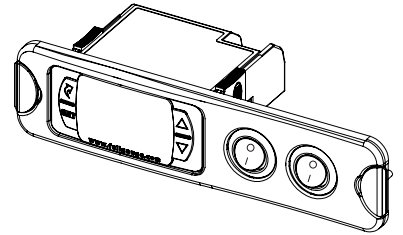

15. ANNEXES - Reference Diagrams

Diagram V

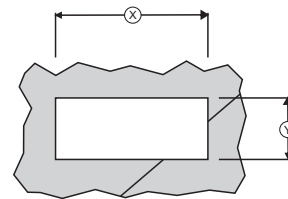

Diagram VI

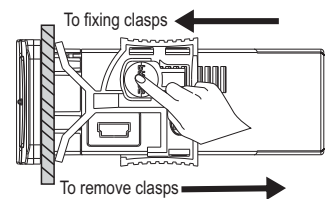
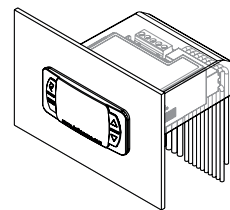
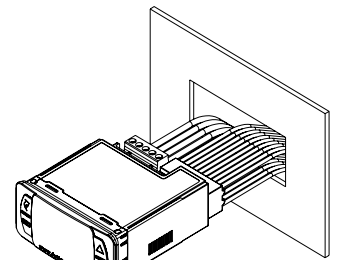
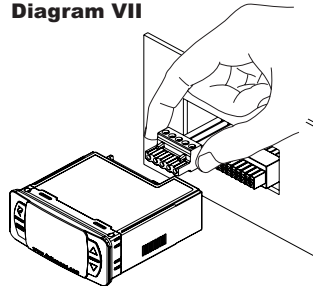
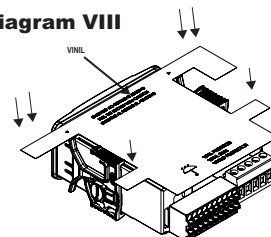

Diagram VII



To ensure it is properly and safely installed, connect all leads before putting the controller in position.

Diagram VIII



16. WARRANTY



ENVIRONMENTAL INFORMATION

Packaging:

Full Gauge products use packaging made from entirely recycled materials. Please dispose of it through specialized recyclers.

Product:

The components used in Full Gauge controllers can be recycled and reused if they are dismantled by specialists.

Disposal:

Do not burn or throw controllers in the domestic waste, once they have reached the end of their working life. Follow the current legislation applicable to your area in relation to disposing of electronic waste. If you have any questions, contact Full Gauge Controls.

WARRANTY - FULL GAUGE CONTROLS

Products manufactured by Full Gauge Controls, from May 2005, have a warranty period of 10 (ten) years direct from the factory and 01 (one) year from accredited retailers, starting from the consignment date on the sales invoice. After this year, the warranty will continue to be honored for purchases from retailers if the device is sent directly to Full Gauge Controls. This period is valid in Brazil. Other countries provide a guarantee for 2 years. The products are guaranteed in the event of a manufacturing fault that makes them unsuitable or inappropriate for the uses to which they were intended. The warranty is limited to the maintenance of devices manufactured by Full Gauge Controls, regardless of any other form of costs, such as any indemnity due to damage caused to other equipment.

WARRANTY EXCEPTIONS

The Warranty does not cover transport and / or insurance costs for sending products believed to have defects or to have malfunctioned to Technical Support. The following events are also not covered: natural wear of parts, external damage caused by falls or improper packing of products.

LOSS OF WARRANTY

The product will automatically no longer be covered if:
- The instructions for use and assembly contained in the technical description and installation procedures listed in the NBR5410 standard are not observed;
- It is subjected to conditions beyond the limits specified in its technical description;
- If it is opened up or repaired by a person who is not part of Full Gauge's technical team;
- The damage which has taken place was the result of a fall, blow or impact, water damage, electrical surge or atmospheric discharge.

USING THE WARRANTY

To take advantage of the warranty, the customer must send the product properly packed, together with the corresponding purchase invoice, to Full Gauge Controls. The delivery cost for the product is borne by the client. You will also need to send as much information as possible regarding the defect that has been detected, thus making it possible to streamline the analysis, testing and servicing.

These processes and any eventual maintenance of the product will only be carried out by Full Gauge Controls' Technical Support, at the Company's head office - Rua Júlio de Castilhos, 250 - Zip Code 92120-030 - Canoas - Rio Grande do Sul - Brazil.

Rev. 03