



TI-44E plus Ver.01

FOUR-SENSOR DIGITAL THERMOMETER WITH SERIAL COMMUNICATION

- Up to four temperature sensors
- Differential temperature calculation
- Average temperature calculation
- Functions lock
- Serial Programming
- Supervisory system
- IP 65 FRONT Protection level



Have this manual in your hands using the FG Finder application.

1. DESCRIPTION

Temperature indicator designed to monitor average, differential or individual temperatures of up-to four sensors. It can be connected to Sitrad real-time monitoring and management software or smartphone APP using RS485 serial communication port. It features IP65 frontal protection, optional drip protection case at rear and tamper-proof function lockdown to prevent unauthorized change of parameters.

2. SAFETY RECOMMENDATIONS

- Check the controller for correct fastening;
- Make sure that the power supply is off and that it is not turned on during the controller installation;
- Read the present manual before installing and using the controller;
- Use adequate Personal Protective Equipment (PPE);
- For application at sites subject to water spills, such as refrigerated counters, install the protecting vinyl supplied with the controller;
- For protection under more critical conditions, we recommend the Ecase cover, which we make available as an optional item (sold separately);
- The installation procedures should be performed by a qualified technician.

3. APPLICATIONS

- Cold storage equipment
- Machine tools
- Stoves
- Furnaces
- Motor vehicles
- Air conditioned rooms
- Food, chemical, and pharmaceutical industries.

4. TECHNICAL SPECIFICATIONS

| | |
|-------------------------|--|
| Power Supply | Ti-44E Plus: 115 or 230 Vac ±10%* (50/60 Hz) Ti-44EL Plus: 12 or 24Vac/dc ±10%* |
| Approximate consumption | 0.6 VA |
| Measurement range (**) | - 50 a 105°C (-58 a 221°F) |
| Operating Temperature | 0 to 50° C / 32 to 122°F |
| Operating humidity | 10 to 90% RH (with no condensation) |
| Dimensions (mm) | 76 x 34 x 77 mm (W x H x D) |
| Cutout dimensions (mm) | X = 71±0,5 Y = 29±0,5 (see Image V) |

! IMPORTANT: Only sensor S1 is included with the product. Sensors S2, S3, and S4 are sold separately.
 (*) Admissible variation in relation to the voltage rating.
 (**) This device can measure temperatures of up to 200°C/392°F, when used in conjunction with the SB59 silicon sensor cable (sold separately).

5. INDICATIONS AND KEYS

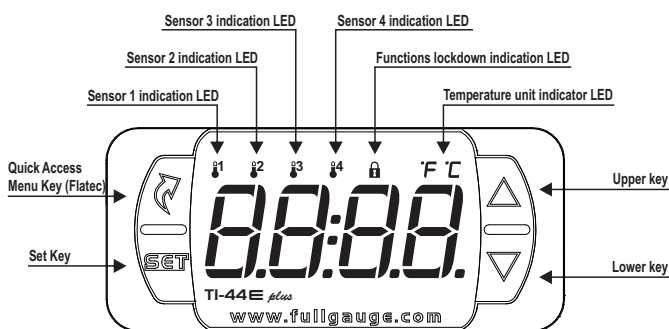

6. WIRING DIAGRAM

6.1. Electrical connections (see Images I to IV)

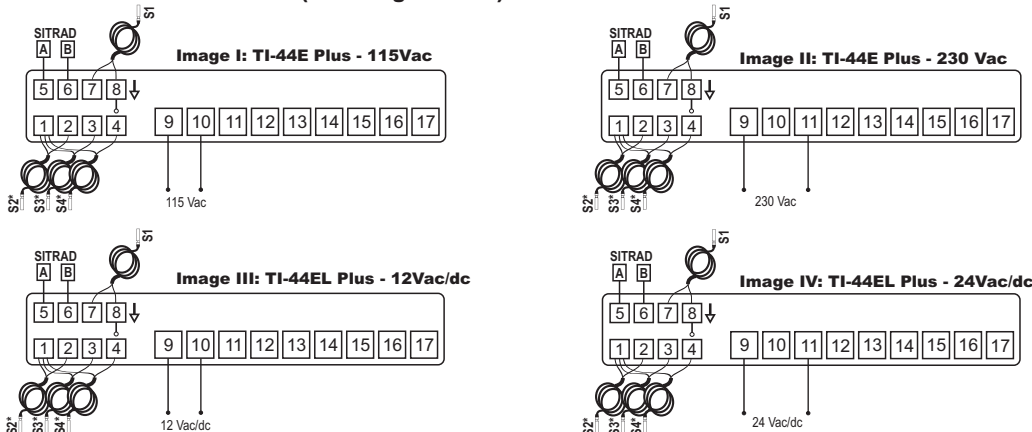

6.2. Temperature sensor connection

- Connect the sensor S1 wires to terminals "7 and 8": the polarity is not relevant.
- The sensor cable can be extended up to 200 meters, by the user itself, using a PP2x24AWG cable.
- For immersion in water, use a thermowell (Image VI - item 13), available in the Full Gauge Controls product line (sold separately).

6.3. Controller power supply

Use the pins according to table below, considering the set version:

| Pins | TI-44E PLUS | TI-44EL PLUS |
|----------|-------------|--------------|
| 9 and 10 | 115 Vac | 12 Vac/dc |
| 9 and 11 | 230 Vac | 24 Vac/dc |

6.4. Recommendations of IEC60364 standard

- a) Install overload protectors in the controller supply.
- b) The sensor cables may be together, but not in the same conduit where the power supply of the controller and/or of the loads passes through.

7. FASTENING PROCEDURE

- a) Cut out the panel plate (Image V - item 13) where the controller shall be fastened, with sizes X = 71±0.5 mm and Y = 29±0.5 mm;
- b) Remove side locks (Image VI - item 13): to do that, compress the central elliptical part (with the Full Gauge Controls logo) and displace the locks backwards;
- c) Introduce the controller in the notch made on the panel, inwards;
- d) Place the locks again and then displace them until they compress into the panel, fastening the controller to the housing (see arrow indication in Image VI - item 13);
- e) Perform the electric installation as described in item 6;
- f) Adjust the parameters as described in item 8.

! ATTENTION: for installations requiring liquid tight sealing, the notch sizes for the controller installation should be no more than 70.5x29 mm. The side locks should be fastened so that they press the sealing rubber avoiding infiltration between the notch and the controller.

Protector vinyl - Image VII (item 13)

It is supplied with the instrument in the package.

! IMPORTANT: Make the application only after completing the electrical connections.

- a) Retreat the side locks (Image VI - item 13);
- b) Remove the protective film from the adhesive vinyl face;
- c) Apply the vinyl over the entire upper part, bending the flaps, as indicated by the arrows - Image VII (item 13);
- d) Reinstall the locks.

NOTE: The vinyl is transparent, allowing visualization of the wiring system of the instrument.

8. ADJUSTMENT OF THE SETPOINT AND PARAMETERS

8.1. Quick Access Menu Map

To access or browse the quick access menu use the key (quick touch) while the controller is displaying the temperature. With each touch the next function in the list is displayed. To confirm use the key (quick touch). See chapter 8.3. for more details. The map of functions is shown below:

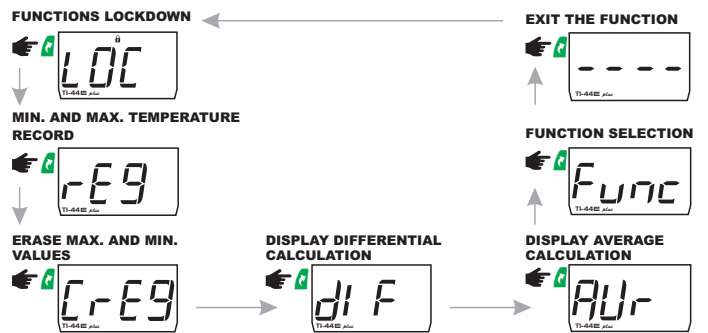

LEGEND:

To the terminal of ↓ the connecting block

! IMPORTANT: Only the sensor 1 is sold with the product, the sensors 2,3 and 4 can be purchased separately.

! IMPORTANT
 INSTRUMENTS IN THE EVOLUTION SERIES HAVE TWO DIFFERENT TERMINAL SIZES, BUT BOTH ARE COMPATIBLE WITH THE SCREWDRIVER 2.0mm. USING THE APPROPRIATE TOOLS DURING INSTALLATION ENSURES A LONGER LIFE AND THE PROPER OPERATION OF THE PRODUCTS.

8.2. Quick access keys map

When controller is on temperature display mode, the following keys can be used as a shortcut for the following functions:

| | |
|--|--|
| | Quick touch: confirmation of the function adjustments. |
| | Hold down for 2 seconds: exit function menu. |
| | Quick touch: display of the maximum and minimum temperatures recorded. |
| | Hold down for 2 seconds: clear history when records are being displayed. |
| | Quick touch: momentarily switches the temperature view. |
| | Quick touch: quick access menu. |
| | Hold down simultaneously: enter function selection. |

8.3. Basic Operations

8.3.1. Viewing other temperatures

To switch between the temperature views for sensor 1, sensor 2, sensor 3, sensor 4, differential temperature, and average temperature, press until the desired temperature is displayed.

| | |
|--|--------------------------|
| | Sensor 1 temperature |
| | Sensor 2 temperature |
| | Sensor 3 temperature |
| | Sensor 4 temperature |
| | Differential temperature |
| | Average temperature |

The selected temperature will be displayed for 15 seconds and then the default indication will return (as per parameter setting). If any temperature is disabled it will not be displayed.

8.3.2. Minimum and Maximum Temperature Record

By pressing the key or also through the quick access menu (see item 8), the message will be displayed and then message indicating the temperature of sensor 1 and the maximum and minimum recorded temperatures immediately after, then sensor 2 temperature , sensor 3 temperature , sensor 4 temperature , differential temperature , and average temperature are displayed. To erase the current minimum and maximum values, press the key (quick touch) until the message is displayed. Press to confirm.

NOTE1: If the key is pressed while the records are being displayed the values will be reset and the message will be displayed.

NOTE2: If any sensor is disabled the respective minimum and maximum temperatures are not displayed.

8.3.3. Unit Selection (°C / °F)

To select the units the instrument will use, access the main menu through the quick access menu () , option or by pressing and simultaneously while the temperature is being displayed, and enter function with the access code and press . Then select the desired unit or using the keys, and press to confirm.

NOTE: Whenever the units are changed, the functions configuration returns to the factory default settings so it must be configured again.

8.3.4. Functions Lockdown

The activation of the function locking feature provides safety by preventing undue changes of the parameters.

In this condition the message will be displayed when trying to change those values. However, it is still possible to view the parameters.

In order to activate the function lock feature, parameter (Time for function lock) must be configured with a value higher than 14 (if it is less than 15, will be displayed meaning that function lock cannot be activated).

Select using the key (quick touch), and then press (quick touch). Then keep pressed until is displayed.

The message will be displayed upon releasing the key.



To unlock, turn the controller off and then turn it on again with the key pressed. Keep the key pressed until is displayed. Keep the key pressed for 10 seconds and, upon releasing the key, the message will be displayed indicating the functions lock is deactivated.

8.4. Advanced operations

8.4.1. Adjustment of the parameters

Access function by pressing keys and simultaneously or through the quick access menu (item 8.1). When is displayed, press key (quick touch). Use the keys or to enter with access code and when ready press . Use the keys or to access the desired function. After selecting the function, press key (quick touch) to view the value configured for that function. Use or to change the value and press to save the configured value and return to the functions menu. To leave the menu and return to the normal operating mode (temperature indication), press (hold down) until is displayed.

NOTE 1: If the functions lock is active, when pressing the keys or the controller will show the message and will not allow the adjustment of the parameters.

NOTE 2: If no button is touched for 15 seconds after providing the access code and / or after configuring the parameter the controller will return to the operating mode and it will be necessary to enter the access code again in function .

8.4.2. Parameters Table

| Fun | Description | CELSIUS (°C) | | | | FAHRENHEIT (°F) | | | |
|-----|---|--------------|-----|------|---------|-----------------|-----|------|---------|
| | | Min | Max | Unit | Default | Min | Max | Unit | Default |
| | Access Code | 0 | 999 | - | 0 | 0 | 999 | - | 0 |
| | Sensor 1 on or off | OFF | ON | - | ON | OFF | ON | - | ON |
| | Sensor 2 on or off | OFF | ON | - | OFF | OFF | ON | - | OFF |
| | Sensor 3 on or off | OFF | ON | - | OFF | OFF | ON | - | OFF |
| | Sensor 4 on or off | OFF | ON | - | OFF | OFF | ON | - | OFF |
| | Indication offset for sensor 1 | -5.0 | 5.0 | °C | 0.0 | -9 | 9 | °F | 0 |
| | Indication offset for sensor 2 | -5.0 | 5.0 | °C | 0.0 | -9 | 9 | °F | 0 |
| | Indication offset for sensor 3 | -5.0 | 5.0 | °C | 0.0 | -9 | 9 | °F | 0 |
| | Indication offset for sensor 4 | -5.0 | 5.0 | °C | 0.0 | -9 | 9 | °F | 0 |
| | Display indication mode | 1 | 7 | - | 1 | 1 | 7 | - | 1 |
| | Differential calculation mode | 0(off) | 6 | - | 0(off) | 0(off) | 6 | - | 0(off) |
| | Average calculation mode | 0(off) | 7 | - | 0(off) | 0(off) | 7 | - | 0(off) |
| | Time for functions lock | (no) | 60 | sec. | (no) | (no) | 60 | sec. | (no) |
| | Address of the instrument in the RS-485 network | 1 | 247 | - | 1 | 1 | 247 | - | 1 |

Legend: = no
 = on
 = off

8.4.3. Description of parameters

F01 - Access Code:

Has two different access codes:

Allows changing the advanced parameters.

Allows choosing the temperature unit: Celsius or Fahrenheit.

F02/F03/F04/F05 - Sensor 1, 2, 3, 4 on or off:

This function configure whether the temperature reading in sensors 1(F02), 2(F03), 3(F04), 4(F05) is enabled. In order to switch off these inputs they must not be in use by any other function and at least one input must be active.

F02 (Sensor 1):

Sensor 1 input off

Sensor 1 input on

F03 (Sensor 2):

Sensor 2 input off

Sensor 2 input on

F04 (Sensor 3):

Sensor 3 input off

Sensor 3 input on

F05 (Sensor 4):

Sensor 4 input off

Sensor 4 input on

F06/F07/F08/F09 - Indication offset for sensor 1(F06), 2(F07), 3(F08), 4(F09):

It allows compensating possible deviations in the temperature reading caused by the replacement of the sensor or changes in the cable length.

F10 - Display indication mode:

This function allows configuring the preferred temperature indication.

- Displays the temperature of sensor 1
- Displays the temperature of sensor 2
- Displays the temperature of sensor 3
- Displays the temperature of sensor 4
- Displays the differential temperature
- Displays the average temperature
- Displays all temperatures in an alternate fashion

NOTE: If any sensor is disabled the option related to that sensor will not be displayed.

F11 - Differential calculation mode:

This function configures how the calculation of the differential temperature is performed.

- Differential calculation off
- Sensor 1 minus sensor 2 temperature
- Sensor 1 minus sensor 3 temperature
- Sensor 1 minus sensor 4 temperature
- Sensor 2 minus sensor 3 temperature
- Sensor 2 minus sensor 4 temperature
- Sensor 3 minus sensor 4 temperature
- Average temperature of all sensors

NOTE: In order to calculate the difference, it is necessary to enable the two relevant sensors. If not enabled, it will not be possible to calculate the difference.

F12 - Average calculation mode:

Configures the mode in which the average temperature calculation between the sensors is performed.

- Average temperature calculation off
- Average temperature between sensor 1 and sensor 2
- Average temperature between sensor 1 and sensor 3
- Average temperature between sensor 1 and sensor 4
- Average temperature between sensor 2 and sensor 3
- Average temperature between sensor 2 and sensor 4
- Average temperature between sensor 3 and sensor 4
- Average temperature of all sensors

NOTE: The sensors that are in error or switched off will not be considered for the calculation of the average temperature of all sensors (option 7).

F13 - Time for functions lock:

It authorizes locking the control functions (see item 8.3.4.).

- - Authorizes functions lock and defines the time in seconds of the command to activate. If a value below 15 is configured, the message will be displayed indicating that locking is not allowed.

F14 - Address of the instrument in the RS-485 network:

Equipment's network address for communicating with Sitrad® software.

NOTE: One network must not have different equipment with the same address.

9. DISPLAY SIGNALINGS

| | |
|----------------|--|
| Err1 | Sensor 1 disconnected or damaged. |
| Err2 | Sensor 2 disconnected or damaged. |
| Err3 | Sensor 3 disconnected or damaged. |
| Err4 | Sensor 4 disconnected or damaged. |
| LOC On | Functions lockdown activated. |
| LOC OFF | Functions lockdown disabled. |
| ECAL | Contact Full Gauge Controls. |
| PPPP | Reconfigure the values of the functions. |

10. GLOSSARY OF ACRONYMS

- °C: Temperature in Celsius degrees.
- °F: Temperature in Fahrenheit degrees.
- LOC: Blocked.
- No: No.
- OFF: Turned off/disabled.
- ON: Turned on, enabled.
- SET (as in "Setting") (setting or configuration).
- Vac: Electrical voltage (volts) of alternating current.
- Vdc: Electrical voltage (volts) of direct current.
- Yes: Yes.

11. OPTIONAL ITEMS - Sold Separately

ECASE protective cover

It is recommended for the Evolution line, avoids water from entering the back part of the instrument. It also protects the product when the installation site is washed.

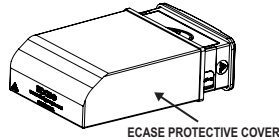

Extended frame

It allows the installation of Evolution line controllers with sizes 76 x 34 x 77 mm in many different situations, since it does not require precision in the notch of the instrument fitting panel.

The frame integrates two switches of 10 Amperes that may be used to actuate interior light, air curtain, fan, and others.

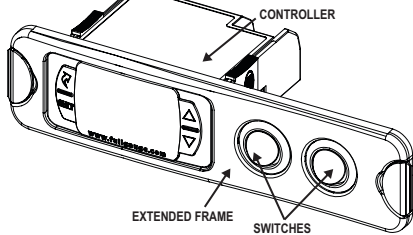

EasyProg - version 2 or higher

It is an accessory that has as its main function to store the parameters of the controllers. At any time, you can load new parameters of a controller and unload them on a production line (of the same controller), for example. It has three types of connections to load or unload the parameters:

- **Serial RS-485:** It connects via RS-485 network to the controller (only for controllers that have RS-485).
- **USB:** It can be connected to the computer via the USB port, using Sitrad's Recipe Editor.
- **Serial TTL:** The controller can be connected directly to EasyProg by the TTL Serial connection.

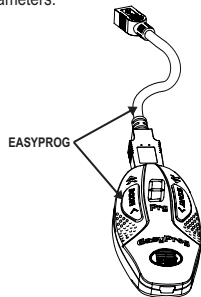

12. INTEGRATING CONTROLLERS, RS-485 SERIAL INTERFACE AND COMPUTER

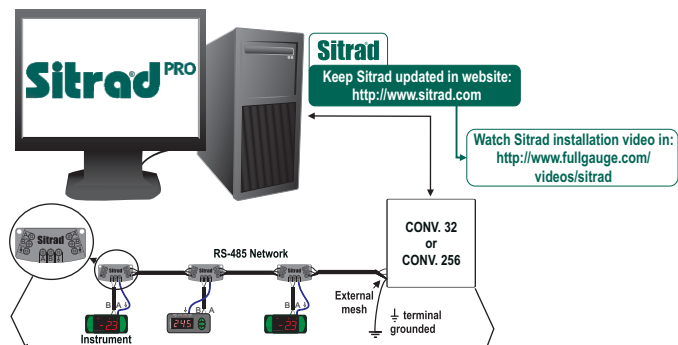

***Connecting Block for Serial Communication**
Used to connect more than one instrument to the Interface. The wire's connections must be made in agreement with the following rules: terminal A of the instrument connects to the terminal A of the connecting block, that must be connected with the terminal A of the Interface. Repeat the action for terminals B and +, being + the cable shield. The terminal ↓ of connecting block must be connected to the respective terminals ↓ of each instrument.

RS-485 Serial Interface
Device used to establish the connection Full Gauge Controls' instruments with the Sitrad'.

*Sold Separately

13. ANNEXES - Reference Images

Image V

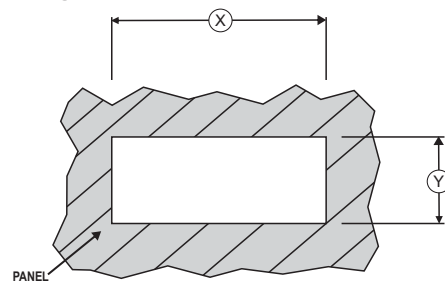

Image VI

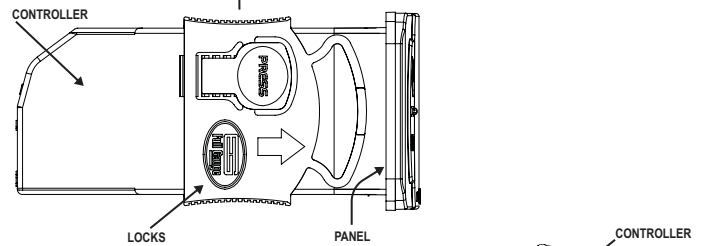
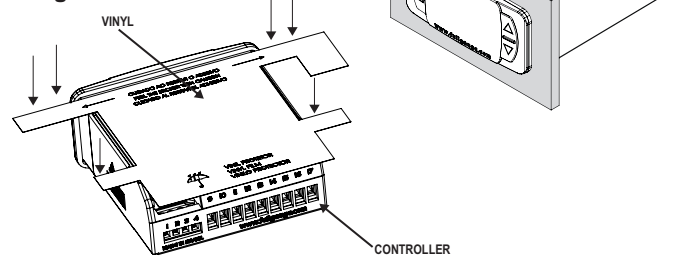

Image VII



ENVIRONMENTAL INFORMATION

Packaging:

The materials used in the packaging of Full Gauge products are 100% recyclable. Try to perform disposal through specialized recyclers.

Product:

The components used in Full Gauge controllers can be recycled and reused if disassembled by specialized companies.

Disposal:

Do not incinerate or dispose the controllers that have reached the end of their service as household garbage. Observe the laws in your area regarding disposal of electronic waste. If in doubt, please contact Full Gauge Controls.

WARRANTY - FULL GAUGE CONTROLS

Products manufactured by Full Gauge Controls, as of May 2005, have a two (02) year warranty, as of the date of the consigned sale, as stated on the invoice. They are guaranteed against manufacturing defects that make them unsuitable or inadequate for their intended use.

EXCEPTIONS TO WARRANTY

The Warranty does not cover expenses incurred for freight and/or insurance when sending products with signs of defect or faulty functioning to an authorized provider of technical support services. The following events are not covered either: natural wear and tear of parts; external damage caused by falls or inadequate packaging of products.

LOSS OF WARRANTY

Products will automatically lose its warranty in the following cases:

- The instructions for assembly and use found in the technical description and installation procedures in Standard IEC60364 are not obeyed;
- The product is submitted to conditions beyond the limits specified in its technical description;
- The product is violated or repaired by any person not a member of the technical team of Full Gauge Controls;
- Damage has been caused by a fall, blow and/or impact, infiltration of water, overload and/or atmospheric discharge.

USE OF WARRANTY

To make use of the warranty, customers must send the properly packaged product to Full Gauge Controls together with the invoice or receipt for the corresponding purchase. As much information as possible in relation to the issue detected must be sent to facilitate analysis, testing and execution of the service.

These procedures and any maintenance of the product may only be provided by Full Gauge Controls Technical Support services in the company's headquarters at Rua Júlio de Castilhos, 250 - CEP 92120-030 - Canoas - Rio Grande do Sul - Brasil

Rev. 03