



TempusE Ver.04

DIGITAL TIMER

- Serial programming
- Buzzer
- IP 65 FRONT Degree of protection



TEMPUSE04-01T-20599 -2605

**1. DESCRIPTION**

A digital timer/counter with programmable time base that operates in both cyclical functions as well as in functions that are triggered by a key/switch. It has an internal audible alarm (buzzer) and an output to activate the process finish alarm and event totalizer. The TempusE allows you to set up to three presets for the timer and counter modes, in addition to the configuration of a delay between timer cycles where two outputs remain off. It also features a digital input to start the cyclical timer, different time units for on and off times in the cyclical timer mode, event accumulator for the timer/counter modes, and counter mode for low frequency counting with dry contact.

Product conforming to UL Inc. (United States and Canada)(\*).

**2. SAFETY RECOMMENDATIONS**

- Check the controller for correct fastening;
- Make sure that the power supply is off and that it is not turned on during the controller installation;
- Read the present manual before installing and using the controller;
- Use adequate Personal Protective Equipment (PPE);
- For application at sites subject to water spills, install the protecting vinyl supplied with the controller;
- The installation procedures should be performed by a qualified technician.

**3. APPLICATIONS**

- Ovens, injection machines, defrost control
- Process monitoring and control.
- Rewinders
- Packing machines
- Electric panels in general

**4. TECHNICAL SPECIFICATIONS**

Electric supply	TempusEL: 12 or 24 Vac/dc ±10%(**) TempusE: 115 or 230 Vac ±10%(**)(50/60 Hz)(*)
Operating temperature	0 to 50 °C / 32 to 122 °F
Maximum current per output	OUT1: 16(12)A 250Vac 1HP OUT2: 10A / 250Vac ¼ HP
Precision (timer/cyclical timer)	0,05% FE
Maximum frequency (counter)	100cps - counts per second (100 Hz)
Counter input	NO/NC (dry contact) No - voltage input
Operating humidity	10 to 90% RH (no condensation)
Dimensions (mm)	76 x 34 x 77 mm (WxHxD)
Dimensions for cutting - to fasten the instrument	71 ± 0,5 x 29 ± 0,5 mm (see image V)

(\*) The model with 115–230 Vac power supply is UL certified.

(\*\*) Allowable variation relative to the nominal voltage.

**5. INDICATORS AND KEYS**

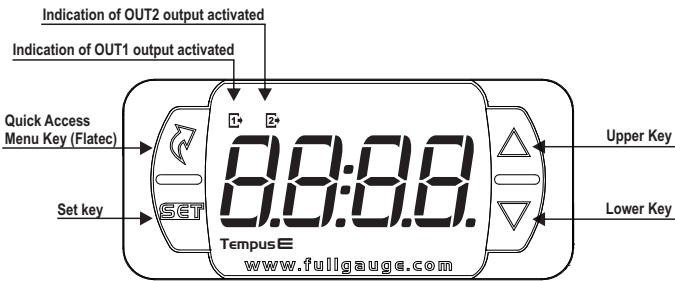

**6. WIRING DIAGRAM**

**6.1. Identifications (see Images I, II, III and IV)**

- Image I: TempusE, supplied at 115 Vac.
- Image II: TempusE, supplied at 230 Vac.
- Image III: TempusEL, supplied at 12 Vac/dc.
- Image IV: TempusEL, supplied at 24 Vac/dc.

**Image I: TempusE - 115Vac**

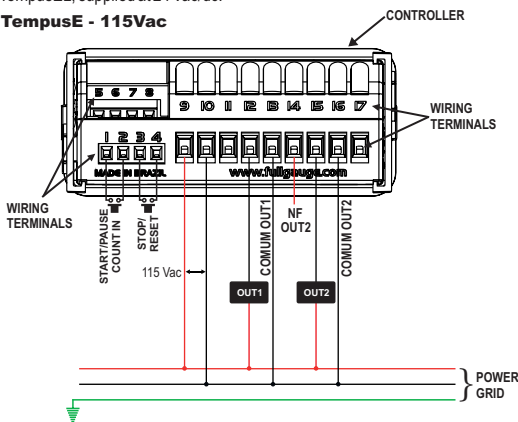

**Image II: TempusE - 230 Vac**

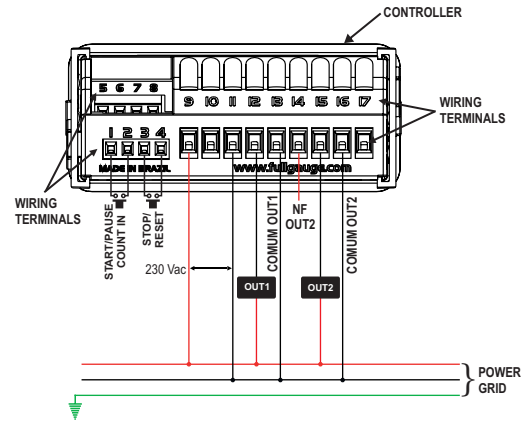

**Image III: TempusEL - 12Vac/dc**

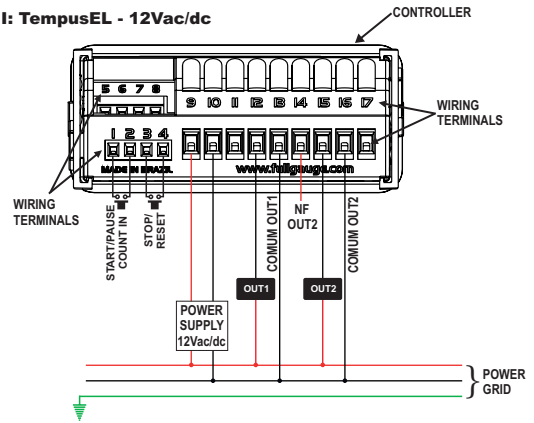

**Image IV: TempusEL - 24Vac/dc**

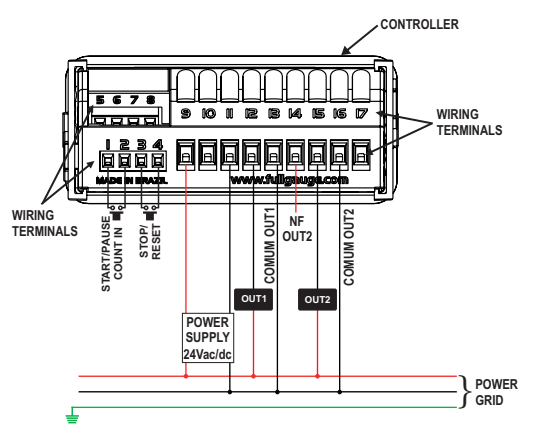

**IMPORTANT**

INSTRUMENTS IN THE EVOLUTION SERIES HAVE TWO DIFFERENT TERMINAL SIZES, BUT BOTH ARE COMPATIBLE WITH THE SCREWDRIVER 2.0MM. USING THE APPROPRIATE TOOLS DURING INSTALLATION ENSURES A LONGER LIFE AND THE PROPER OPERATION OF THE PRODUCTS.

**Surge Protective Device (SPD) (sold separately)**

**Wiring diagram for installation of SPD in magnetic contactor**

A1 and A2 are the terminals of the contactor coil.

**Wiring diagram for installation of SPD in line with loads**

For direct drive take in to consideration the specified maximum current.

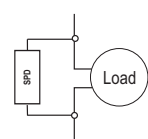
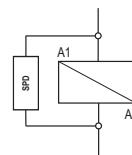

## 6.2. Controller power supply

Use the pins according to table below, considering the set version:

Pins	TEMPUS EL	TEMPUS E
9 and 10	12 Vac / dc	115 Vac
9 and 11	24 Vac / dc	230 Vac

## 6.3. Recommendations of IEC60364 standard

- Install overload protectors in the controller supply.
- Install transient suppressors - suppressor filter RC - in the circuit to increase the service life of the controller relay. See connection instructions of the filter on the previous page.

## 7. FASTENING PROCEDURE

- Cut out the panel plate (Image V - item 14) where the controller shall be fastened, with sizes  $X = 71 \pm 0.5$  mm and  $Y = 29 \pm 0.5$  mm;
- Remove side locks (Image VI - item 14): to do that, compress the central elliptical part (with the Full Gauge Controls logo) and displace the locks backwards;
- Introduce the controller in the notch made on the panel, inwards;
- Place the locks again and then displace them until they compress into the panel, fastening the controller to the housing (see arrow indication in Image VI - item 14);
- Perform the electric installation as described in item 6;
- Adjust the parameters as described in item 10.

**⚠ ATTENTION:** for installations requiring liquid tight sealing, the notch sizes for the controller installation should be no more than 70.5x29mm. The side locks should be fastened so that they press the sealing rubber avoiding infiltration between the notch and the controller.

**Protector vinyl** - Image VII (item 14)

It protects the controller when installed at a site subject to water spills, such as refrigerated counters. This adhesive vinyl is supplied with the instrument in the package.

**⚠ IMPORTANT:** Make the application only after completing the electrical connections.

- Retreat the side locks (Image VI - item 14);
- Remove the protective film from the adhesive vinyl face;
- Apply the vinyl over the entire upper part, bending the flaps, as indicated by the arrows - Image VII (item 14);
- Reinstall the locks.

**NOTE:** The vinyl is transparent, allowing visualization of the wiring system of the instrument

## 8. OPERATIONS

### 8.1. Quick Access Menu Map

Use the **FLATEC** key (F1) to access or browse the quick access menu. With each press the next function in the list is displayed. Use the **QUICK TOUCH** key (F2) to confirm. See chapter 9 for more details. The map of functions is shown below:

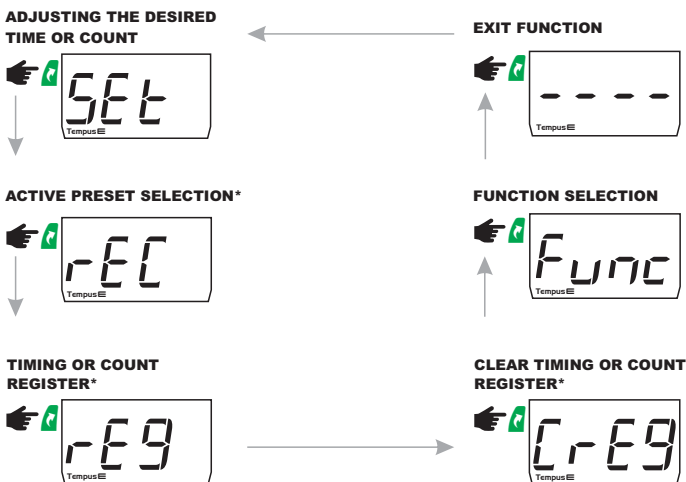

\* Available in timer or counter modes.

### 8.2. Map of quick access keys

	Pressed for 2 seconds: adjustment of the timing or count.
	Quick touch: confirmation of parameters.
	Quick touch: (STOP) Resets counting or timing (timer mode) pain, counter mode and cyclic mode when $[d, 1] = [d, 5]$ .
	Pressed for 2 seconds: inhibits audible alarm (timer mode and counter mode).
	Pressed 4 seconds: synchronizes cyclical timer, inverts timer status cyclic (except when $[d, 1] = [d, 5]$ )
	Short press: (START / PAUSE) Starts / Pauses timing or counting (timer mode or counter mode) and starts counting in mode cyclic timer when $[d, 1] = [d, 5]$
	Enter the quick access menu.
	Enter function selection.

## 9. BASIC OPERATIONS

### 9.1 Adjusting the desired timing or count

- Keep the **FLATEC** key pressed for 2 seconds until the message **5E6** is displayed;
- The currently active preset **rE1**, **rE2** or **rE3** is displayed in timer or counter modes;
- Use the keys **FLATEC** or **QUICK TOUCH** to change the preset and press **QUICK TOUCH** to confirm.
- In the cyclical timer mode the message **EDn** relating to the output On time is displayed and the message **EOFF** relating to the output off time is displayed after the first parameter is adjusted;

### 9.2 Preset selection (timer or counter modes)

- Enter the quick access menu using the **FLATEC** key (F1) until the message **rE1** is displayed and press **QUICK TOUCH** to confirm;
- The currently active preset **rE1**, **rE2** or **rE3** will be displayed;
- Use the keys **FLATEC** or **QUICK TOUCH** to change the active preset by pressing **QUICK TOUCH** for two seconds until the message **---** is displayed to confirm.

### 9.3 Viewing the register of completed timings or counts

- Enter the quick access menu using the **FLATEC** key (F1) until the message **rE9** is displayed and press **QUICK TOUCH** to confirm;
  - The currently active preset **rE1**, **rE2** or **rE3** will be displayed;
  - Then the number of completed timings or counts of each preset currently active will be displayed.
- NOTE:** In case of an electric power outage, the registers will be reset.

### 9.4 Clearing the registers of completed timings or counts

- Enter the quick access menu using the **FLATEC** key (F1) until the message **CrE9** is displayed and press **QUICK TOUCH** to confirm;
  - The currently active preset **rE1**, **rE2** or **rE3** will be displayed.
  - Then the number of completed timings or counts of the preset currently active **rE1** will be displayed.
- NOTE:** Presets and recording/clearing of completed timings or counts are not available in the cyclical timer mode. The message **---** will be displayed upon entering these functions if configured in the cyclical timer mode.

### 9.5 Cyclical timer synchronization

To synchronize the process, press the **STOP** key for 4 seconds and the status of the following cycle **EDn** or **EOFF** will be displayed, which will start immediately after the **STOP** key is released.

## 10. ADVANCED OPERATIONS

### 10.1 Access to the main menu

The main menu can be accessed through the quick access menu, option **Func** or by pressing **FLATEC** and **QUICK TOUCH** simultaneously (quick touch). The setup parameters are protected by the access code.

### 10.2 Access code [ode]

To allow the altering of parameters, enter the option **[ode]** by pressing **QUICK TOUCH**, enter the access code **123** (one hundred and twenty-three) using the **FLATEC** or **QUICK TOUCH** keys, and confirm with **QUICK TOUCH**.

### 10.3 Accessing the operating modes

Use the **FLATEC** or **QUICK TOUCH** keys to choose the operating mode and then press the **QUICK TOUCH** key (quick touch) to confirm and return to the functions menu. To leave the functions menu and return to the normal operating mode, press **QUICK TOUCH** until **---** is displayed.

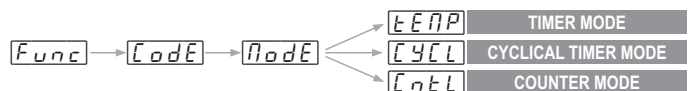

**NOTE:** Parameters **[disP]**, **[BLr]**, **[YPE]** and **[bUS]** are available in different modes. However, these are independent for each mode and must be configured in accordance with the operating mode selected.

### 10.4 TIMER MODE

#### 10.4.1 Operation

In this mode the process is started by pressing the **START** key or through the digital input START/PAUSE. Then the output OUT1 is activated and the count of the adjusted time is started. The counting is paused if the **START/PAUSE** key or the digital input START/PAUSE is pressed during this cycle. If the parameter **[PouE]** is configured as **[On]**, output OUT1 will stay activated and the time indication will keep flashing on the display.

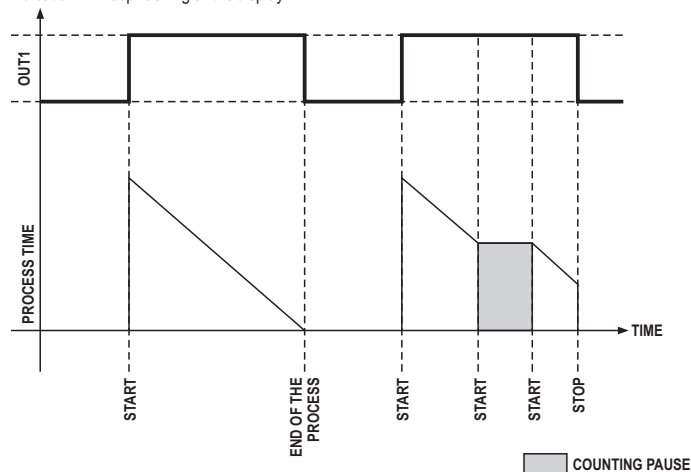

If the parameter **[PouE]** is configured as **[OFF]**, output OUT1 is switched off and the time indicator keeps flashing on the display.

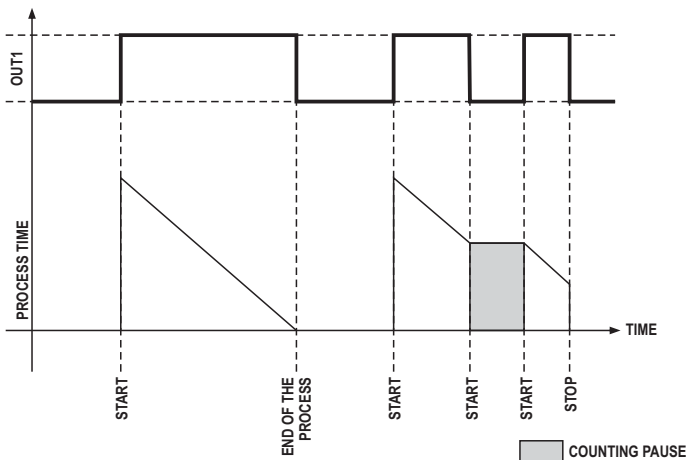

**NOTE:** The parameter  $[P_{out}]$  is configured as  $[0n]$  as factory default.

A new pressing on the  $\square$  key or activation of the digital input START/PAUSE resumes the counting. To interrupt the process, just press the  $\square$  key or activate the digital input STOP. When the process is finished, output OUT1 is switched off and output ALARM is switched on for the time adjusted in parameter  $[t_{ALr}]$ , together with the indication  $[t_{nd}]$  flashing.

### 10.4.2 Setup

The timer mode allows configuring 3 timers with different units and times. These timers are called "presets." These presets on the function menu are available to the user through the quick access menu, making it easier to operate machines with different timings. When choosing the timer mode on the function menu  $[t_{EEP}]$ , it is possible to change the parameters relating to this operating mode in the following order:

- $[U_{n1}]$  - Units of the preset's time base  $[r_{t1}]$ :
- $[SEc]$  - Seconds and hundredths.
- $[M_{in}]$  - Minutes and seconds.
- $[H_{our}]$  - Hours and minutes.

#### $[t_{r1}]$ - Timing of preset $[r_{t1}]$ :

This parameter allows changing the desired value of the preset's timing in accordance with the time base previously chosen. This parameter can also be changed in the quick access menu (see item 8.1).

**NOTE:** Preset  $[r_{t1}]$  is active by factory default.

#### $[U_{n2}]$ - Units of the preset's time base $[r_{t2}]$ :

- $[SEc]$  - Seconds and hundredths.
- $[M_{in}]$  - Minutes and seconds.
- $[H_{our}]$  - Hours and minutes.

#### $[t_{r2}]$ - Timing of preset $[r_{t2}]$ :

This parameter allows the altering of the desired value of the preset's timing in accordance with the time base previously chosen. This parameter can also be changed in the quick access menu (see item 8.1).

#### $[U_{n3}]$ - Units of the preset's time base $[r_{t3}]$ :

- $[SEc]$  - Seconds and hundredths.
- $[M_{in}]$  - Minutes and seconds.
- $[H_{our}]$  - Hours and minutes.

#### $[t_{r3}]$ - Timing of preset $[r_{t3}]$ :

This parameter allows the altering of the desired value of the preset's timing in accordance with the time base previously chosen. This parameter can also be changed in the quick access menu (see item 8.1).

**NOTE:** The following parameters:  $[d_{iSP}]$ ,  $[t_{ALr}]$ ,  $[t_{YPE}]$ ,  $[b_{U2P}]$  and  $[P_{out}]$  are common to all presets in the timer mode.

#### $[d_{iSP}]$ - View of the timing in the timer mode:

This establishes the mode in which the timing will be displayed.

- $[d_{ECr}]$  - Timer in regressive mode.
- $[InCr]$  - Timer in progressive mode.

#### $[t_{ALr}]$ - Process end alarm time:

This takes values between 0 and 999 seconds, which correspond to the time the alarm output remains activated after the end of timing. If a value greater than 999 seconds is configured, the message  $[P_{rES}]$ , is displayed indicating that the alarm output will be kept activated indefinitely until the key  $\square$  or the button panel of the digital input STOP is pressed.

The alarm at the end of the process can be deactivated by adjusting this function with the minimum value 0  $[0n]$ . In this case, the alarm output is ignored at the end of the timing.

#### $[t_{YPE}]$ - Type of operation of the timing alarm:

- $[PULS]$  - Pulsating.
- $[Cont]$  - Continuous.

#### $[b_{U2P}]$ - Internal buzzer in timer mode:

If enabled, the internal buzzer operates in pulsating mode indicating the end of the timing process. The time of oscillating buzzer is the same time used for the end of process alarm.

- $[OFF]$  - Disable internal buzzer.
- $[0n]$  - Enable internal buzzer.

When activated, the buzzer can be inhibited by pressing  $\square$  for two seconds.

#### $[P_{out}]$ - State of output OUT1 with paused timing:

- $[0n]$  - Output OUT1 remains on with the timing paused.
- $[OFF]$  - Output OUT1 is switched off with the timing paused.

### Examples:

To configure the instrument in the **Timer Mode** using the preset  $[r_{t1}]$ , with output OUT1 on for 1 min. and 30 sec. in progressive viewing mode starting when the key  $\square$  is pressed or the external button panel through digital input START/PAUSE is activated, with the internal buzzer switched on and with the alarm output activated in pulses for 10 sec. to indicate the end of process, just configure the instrument with the following values:

- $[t_{odE}] = [t_{EEP}]$
- $[U_{n1}] = [M_{in}]$
- $[t_{r1}] = [0130]$
- $[d_{iSP}] = [InCr]$
- $[t_{ALr}] = [0010]$
- $[t_{YPE}] = [PULS]$
- $[b_{U2P}] = [0n]$

## 10.5 CYCLICAL TIMER MODE:

### 10.5.1 Operation

This mode allows the adjusting of  $[t_{on}]$  and  $[t_{off}]$ , which indicate the duration of the active and inactive cycles respectively.

The operation of the equipment starts with the active or inactive cycle depending on the parameter  $[StEt]$ .

For the **active cycle**, output OUT1 is activated and the count of the time configured in parameter  $[t_{on}]$  is started, while output OUT2 remains off.

For the **inactive cycle**, output OUT1 is switched off and the count of the time configured in parameter  $[t_{off}]$  is started, while output OUT2 remains on.

You can also configure independent intermediate delay times between the active and inactive states through the parameter  $[d_{tOn}]$  and  $[d_{tOff}]$  where the two outputs OUT1 and OUT2 remain off. Using this, you can configure different times for ON and OFF delay times, or even set a delay for only one of the states.

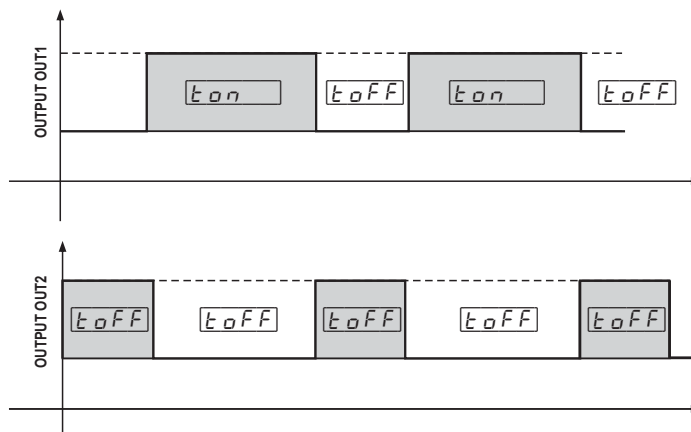

### 10.5.2 Setup

With the cyclical timer selected, the following configurations are available.

#### $[U_{tOn}]$ - ON time base units:

Establishes the time base for which the cyclical timer will remain on (On time).

- $[SEc]$  - Seconds and hundredths.
- $[M_{in}]$  - Minutes and seconds.
- $[H_{our}]$  - Hours and minutes.

#### $[t_{on}]$ - Output OUT1 switched on time:

This parameter allows changing the time for which output OUT1 will remain on in accordance with the time base previously selected.

This parameter can also be changed in the quick access menu (see item 8.1).

#### $[U_{tOff}]$ - OFF time base units:

Establishes the time base for which the cyclical timer will remain off (Off time).

- $[SEc]$  - Seconds and hundredths.
- $[M_{in}]$  - Minutes and seconds.
- $[H_{our}]$  - Hours and minutes.

#### $[t_{off}]$ - Output OUT1 switched off time:

This parameter allows the time for which output OUT1 will remain off to be changed in accordance with the time base previously selected.

This parameter can also be changed in the quick access menu (see item 8.1).

**NOTE:** It is important to notice that there is no limitation for the minimum On or Off times, except for the resolution of the scale adopted. However, it is not recommended to use particularly short cycles to avoid compromising the lifespan of the relay.

#### $[d_{iSP}]$ - Timing view:

This establishes the mode in which the timing will be displayed.

- $[d_{ECr}]$  - Timer in regressive mode.
- $[InCr]$  - Timer in progressive mode.

#### $[StEt]$ - Initial state of the Cyclical Timer:

Establishes the initial state of output OUT1.

- $[0n]$  - Output OUT1 on.
- $[OFF]$  - Output OUT1 off.

**NOTE:** If a delay time is configured for the respective output selected in this parameter, this delay will prevail before the initial state.

### [d i 1] - Digital input to START the Cyclical Timer:

Establishes the activation mode of the cyclical timer through the digital input START.

[Y E S] - Output OUT1 will remain cycling regardless of the closure of the digital input START.

[n o] - Output OUT1 is only activated if the contact of the digital input START is closed, ensuring more safety in the process. If the contact is opened during the cycle, the count is reset and OUT1 is switched off. If the contact is closed again, the timer is started in accordance with the value configured in [S t r t].

[d i 5] - The timer is started when the START key or the button of the digital input, START / PAUSE, are pressed. When the controller detects either of these touches, the timer starts and the output is triggered according to the configured parameters. To interrupt the process, you can press the STOP key or the button connected to the STOP digital input of the controller.

[d i n] - Selects the number of cycles the timer will run through when the function [d i 1] Digital input for START is set to [d i 5]. Therefore, it is possible to configure, for example, for how many cycles the timer will carry out after the timer starts, where the amount configured in this function will be carried out and then the timer will be turned off. If a finite number of cycles is not required, this count can be ignored by lowering the setting of this function until [n o] appears on the display.

### [d t o n] - Delay time before the "T on" state:

Determines the delay time (in minutes / seconds) before the ON state (output OUT1) is activated. During this time, both outputs OUT1 and OUT2 remain off and the LED will flash rapidly indicating that the OUT1 output is currently being delayed. This time will also be initiated when the controller is switched on, where the ON option is set as part of the initial state of the [S t r t] parameter.

### [d t o f] - Delay before the "T off" state:

Determines the delay time (in minutes / seconds) before the OFF state (OUT2 output) is activated. During this time, both outputs OUT1 and OUT2 remain off and the LED will flash rapidly indicating that the OUT2 output is currently being delayed. This time will also be considered when the controller is started when the OFF option is configured in the initial state of the [S t r t] parameter.

### Examples:

[n o d e] = [C Y C L]

[u t o n] = [n o]

[t o n] = [0 5 : 0 0]

[u t o f] = [h o u r]

[t o f f] = [0 2 : 3 0]

[d i s p] = [d e c r]

[S t r t] = [0 n]

[d i 1] = [O F F]

[d i n] = [n o]

[d t o n] = [0 0 : 0 0]

[d t o f] = [0 0 : 0 0]

## 10.6 COUNTER MODE

### 10.6.1 Operation

In this mode, digital input Count in is used to count pulses NO or NC (dry contact). It is possible to determine the counting factor through the parameter [F c n t].

During the counting process, output OUT1 remains on and is switched off when the count reaches the preset (desired value for the count). When this counting ends it is also possible to activate output ALARM and the internal buzzer to indicate that the count is over.

If the parameter [r e s e t] is configured as [0 n] and if the key [ ] or digital input START/PAUSE is pressed during the count, output OUT1 is switched off and the count is reset.

### 10.6.2 Configuration

With the counter mode selected, the following configurations are available.

#### [P r e 1] - Adjustment of preset [r c 1]:

This parameter allows changing the desired value for the preset's counting. This parameter can also be changed in the quick access menu (see item 8.1).

**NOTE:** Preset [r c 1] is active by factory default.

#### [P r e 2] - Adjustment of preset [r c 2]:

This parameter allows changing the desired value for the preset's counting. This parameter can also be changed in the quick access menu (see item 8.1).

#### [P r e 3] - Adjustment of preset [r c 3]:

This parameter allows changing the desired value for the preset's counting. This parameter can also be changed in the quick access menu (see item 8.1).

**NOTE:** The following parameters: [F c n t], [d i s p], [t p u l], [t a l r], [b u s s] and [r e s e t] are common to all presets in the counter mode.

#### [F c n t] - Counting factor:

This parameter allows changing the value by which the counter will be incremented/decremented for each pulse.

Exemplo:

[ ] - The counter is incremented/decremented for each pulse.

[ 2 ] - The counter is incremented/decremented every two pulses.

[ 1 0 0 0 ] - The counter is incremented/decremented every 1000 pulses.

#### [d i s p] - Count view in the Counter mode:

It establishes the mode how the count will be displayed.

[i n c r] - Count in progressive mode.

[d e c r] - Count in regressive mode.

#### [t p u l] - Type of contact in the pulse counter input:

It determines the type of pulse in the digital input START to read the count.

[n o] - Normally open contact (NO), active when the contact is closed or leading edge.

[n c] - Normally closed contact (NC), active when the contact is opened or trailing edge.

#### [F r e] - Pulse frequency for counting:

[ ] - Below 10 Hz.

[ ] - Between 10 Hz and 100 Hz.

#### [t a l r] - Time of the end of count alarm:

It takes values between 0 and 999 seconds, which correspond to the time the alarm output remains activated after the count ends. If configured with a value greater than 999 seconds, the message [P r e 5] is displayed indicating that the alarm output will be kept activated indefinitely until the key [ ] or the button panel of the digital input STOP is pressed.

The alarm at the end of the counting process can be deactivated by adjusting this function with the minimum value 0 [n o]. In this case, the alarm output is ignored at the end of count.

#### [t y p e] - Type of operation of the counting alarm:

[P u l s] - Pulsating.

[c o n t] - Continuous.

#### [b u z z] - Internal buzzer in counter mode:

If enabled, the internal buzzer operates in pulsating mode indicating the end of the counting process. The time of oscillating buzzer is the same time used for the end of counting alarm.

[O F F] - Disable internal buzzer.

[0 n] - Enable internal buzzer.

When activated, the buzzer can be inhibited by pressing [ ] for two seconds.

#### [r e s e t] - Counter mode reset:

[0 n] - Output OUT1 is switched off and the count is reset if the contact of digital input STOP is closed or the key [ ] is pressed during the count.

[O F F] - It is not possible to reset the count. The count is reset only when it reaches the preset or the controller is reset.

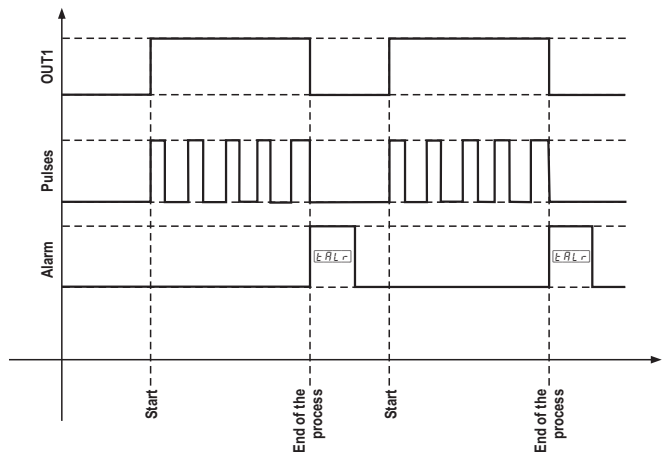

### Examples:

To configure the instrument in the Counter mode to count 1 package for each 100 parts packed. With pulse type NO (leading edge), progressive viewing mode, with 10-sec pulsating alarm, internal buzzer on during the alarm, without a count reset option, just configure the device with the following values:

[n o d e] = [c n t r]

[F c n t] = [1 0 0]

[d i s p] = [i n c r]

[t p u l] = [n o]

[t a l r] = [1 0]

[t y p e] = [P u l s]

[b u s s] = [0 n]

[r e s e t] = [O F F]

## 11. SIGNALING

[E n d]	End of process (timer mode and counter mode).
[P r e 5]	End of process, waiting for STOP in timer mode or START/PAUSE in counter mode.
[r e s e t]	Event totalizer reset (timer mode and counter mode).
[i n i b]	Buzzer inhibited.
[E C A L]	Contact Full Gauge Controls.
[P P P P]	Reconfigure the values of the functions.

## 12. GLOSSARY OF ACRONYMS

- No: No.

- OFF: Turned off/disabled.

- ON: Turned on, enabled.

- SET (as in "Setting") (setting or configuration).

- Vac: Electrical voltage (volts) of alternating current.

- Vdc: Electrical voltage (volts) of direct current.

- Yes: Yes.

### 13. OPTIONAL ITEMS - Sold Separately

#### Ecase protective cover

It is recommended for the Evolution line, keeps water from entering the back part of the instrument. It also protects the product when the installation site is washed.

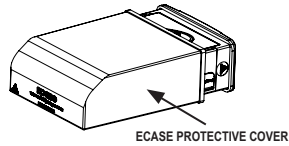

#### Extended frame

It allows the installation of Evolution line controllers with sizes 76 x 34 x 77 mm in various situations, since it does not require precision in the notch of the instrument fitting panel. The frame integrates two switches of 10 Amperes that may be used to actuate interior light, air curtain, fan, and others.

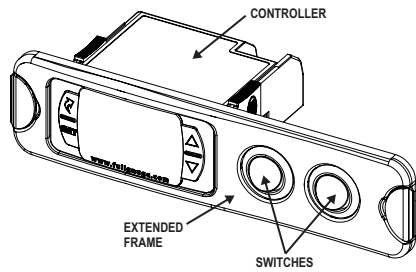

#### EasyProg - version 2 or higher

It is an accessory that has as its main function to store the parameters of the controllers. At any time, you can load new parameters of a controller and unload them on a production line (of the same controller), for example. It has three types of connections to load or unload the parameters:

- **Serial RS-485:** It connects via RS-485 network to the controller (only for controllers that have RS-485).
- **USB:** it can be connected to the computer via the USB port, using Sitrad's Recipe Editor.
- **Serial TTL:** The controller can be connected directly to **EasyProg** by the TTL Serial connection.

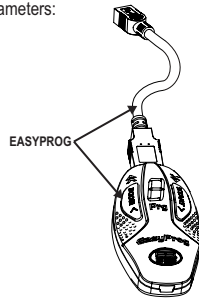

### 14. ANNEXES - Reference Images

#### Image V

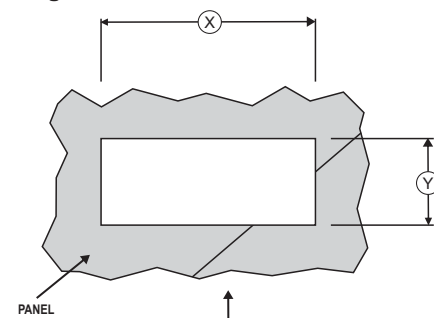

#### Image VI

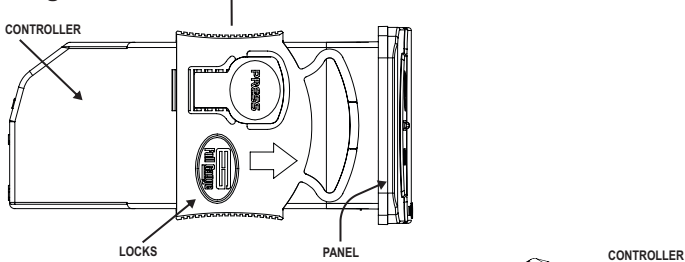

#### Image VII

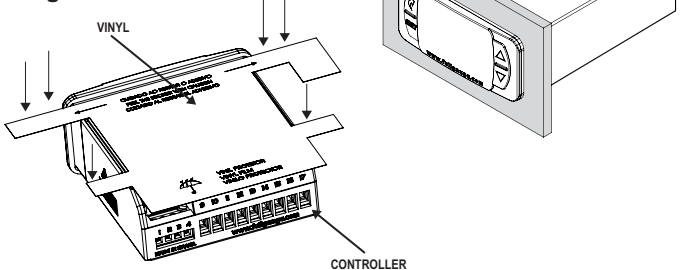

### 15. WARRANTY



#### ENVIRONMENTAL INFORMATION

##### Packaging:

The materials used in the packaging of Full Gauge products are 100% recyclable. Try to perform disposal through specialized recyclers.

##### Product:

The components used in Full Gauge controllers can be recycled and reused if disassembled by specialized companies.

##### Disposal:

Do not incinerate or dispose the controllers that have reached the end of their service as household garbage. Observe the laws in your area regarding disposal of electronic waste. If in doubt, please contact Full Gauge Controls.

### WARRANTY - FULL GAUGE CONTROLS

Products manufactured by Full Gauge Controls, as of May 2005, have a two (02) year warranty, as of the date of the consigned sale, as stated on the invoice. They are guaranteed against manufacturing defects that make them unsuitable or inadequate for their intended use.

#### EXCEPTIONS TO WARRANTY

The Warranty does not cover expenses incurred for freight and/or insurance when sending products with signs of defect or faulty functioning to an authorized provider of technical support services. The following events are not covered either: natural wear and tear of parts; external damage caused by falls or inadequate packaging of products.

#### LOSS OF WARRANTY

Products will automatically lose its warranty in the following cases:

- The instructions for assembly and use found in the technical description and installation procedures in Standard IEC60364 are not obeyed;
- The product is submitted to conditions beyond the limits specified in its technical description;
- The product is violated or repaired by any person not a member of the technical team of Full Gauge Controls;
- Damage has been caused by a fall, blow and/or impact, infiltration of water, overload and/or atmospheric discharge.

#### USE OF WARRANTY

To make use of the warranty, customers must send the properly packaged product to Full Gauge Controls together with the invoice or receipt for the corresponding purchase. As much information as possible in relation to the issue detected must be sent to facilitate analysis, testing and execution of the service. These procedures and any maintenance of the product may only be provided by Full Gauge Controls Technical Support services in the company's headquarters at Rua Júlio de Castilhos, 250 - CEP 92120-030 - Canoas - Rio Grande do Sul - Brasil

Rev. 03

©Copyright 2020 • Full Gauge Controls® • All rights reserved.